

Parts Information:
**Electromig Electronic MIG Welder 195Amp
 230V**
Model No: ELECTROMIG195.V3

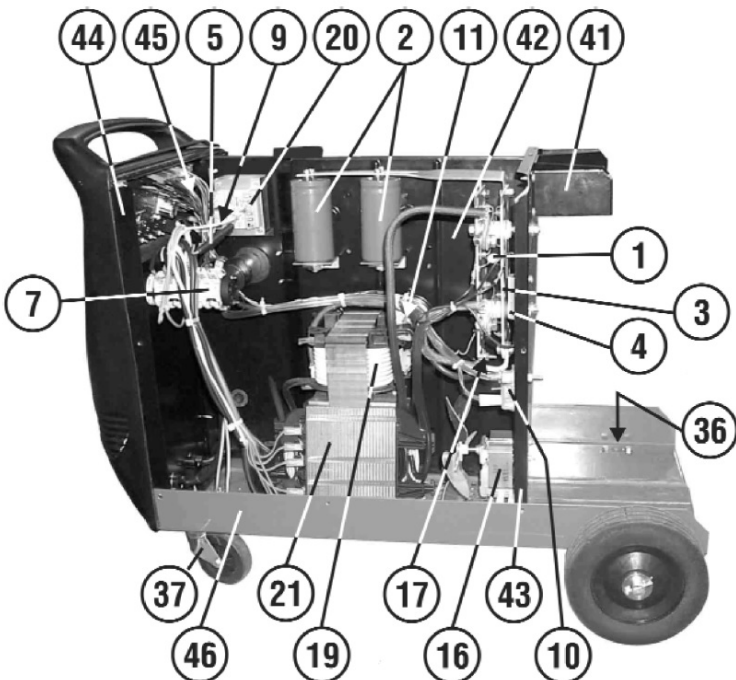
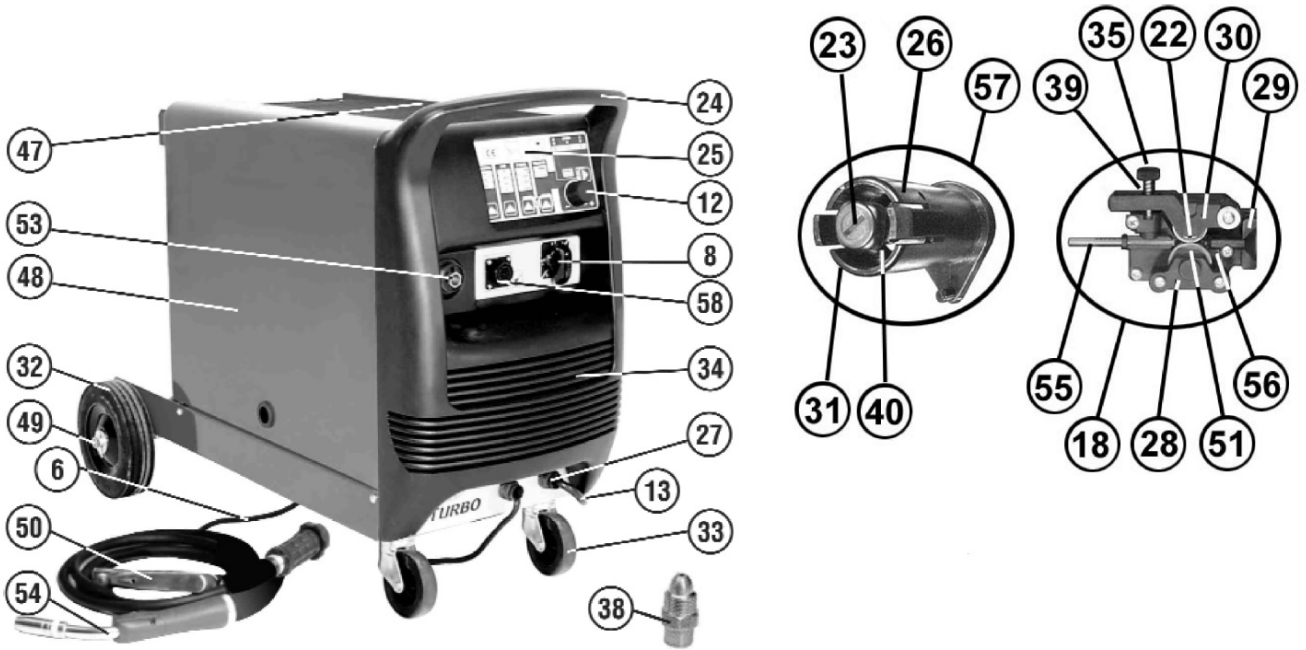

NOTE: It is our policy to continually improve products and as such we reserve the right to alter data, specifications and component parts without prior notice.

IMPORTANT: No liability is accepted for incorrect use of product.

WARRANTY: Guarantee is 12 months from purchase date, proof of which will be required for any claim.



Parts Information:
**Electromig Electronic MIG Welder 195Amp
230V**
Model No: ELECTROMIG195.V3

Item	Part No.	Description
1	120/112183	Protection, rectifier
2	120/112205	Condensor /capacitor 15000uf 53vdc 1012 110x55.
3	120.980476	Rectifier kit
4	120/113684	Resistor
5	120/120097	Fuse cable
6	CC16/1	16mm copper cable per meter
7	120/121035	Switch
8	120.322900	Switch knob
9	120/122190	Fuse t500ma 250v 2x0.5
10	120/122682	Electro-valve 24v
11	120/121093	Thermostat
12	120/990026	Knob kit
13	120/132267	Mains cable 3g02.50 2.50m
15	120/152054	Blade, fan
16	120/152110	Motor, fan
17	120/152219	Shunt
18	120/153007	Wire feed motor
19	120.169371	Reactance
20	120/169122	Auxiliary transformer
21	120.169297	Transformer
22	B/609Z	Bearing 609z
23	120/312137	Knob
24	120/312328	Handle
25	120.980662	Front panel + card set
26	120/322081	Spindle, sleeve/spacer type
27	120.990439	Cable bushing kit
28	120/322126	Casing, feeder roller shaft
29	120/322127	Casing, torch fixing
30	120/322128	Bracket, counter roller
31	120/322180	Spacer collar

Item	Part No.	Description
32	120/322201	Wheel, fixed (173x16x41)
33	120/322245	Wheel, fixed (80x9x23)
34	120/322528	Front panel
35	120/422257	Knob, counter roller tension
36	120/422817	Bracket, axle
37	120/422820	Bracket, castor
38	120/432102	Bull Nose Adaptor
39	120/452022	Spring, counter roller tension
40	120/452057	Spring
41	120/644606	Bracket
42	120/644827	Diaphragm
43	120/644828	Back panel
44	120/644831	Front panel
45	120/644832	Card cover
46	120.644961	Bottom (black)
47	120/655200	Cover
48	120/655201	Door
49	120/681092	Axle, wheel
50	120/712231	Work clamp
51	120/722019	Feed roller 0.6-0.8/0.9mm
53	120/723051	Connection, torch
54	MIG/T15	MIG Torch 3mtr Euro Connector TB15
55	120/990097	Guide hose 2mm x 4mm x 122mm
56	120/990257	Gear set
57	120/990264	Spindle kit
58	120/120351	Cable card/connector
--	REG/MT	MIG Gas Regulator 2 Gauge Industrial (NOT SHOWN)
--	MIG/SGT15	Spool-On-Gun Torch 6mtr TB15(NOT SHOWN)
--	MIG/SGT15/12	Spool-On-Gun Torch 12mtr TB15(NOT SHOWN)

NOTE: It is our policy to continually improve products and as such we reserve the right to alter data, specifications and component parts without prior notice.

IMPORTANT: No liability is accepted for incorrect use of product.

WARRANTY: Guarantee is 12 months from purchase date, proof of which will be required for any claim.

Sealey Group, Kempson Way, Suffolk Business Park, Bury St Edmunds, Suffolk. IP32 7AR



01284 757500



01284 703534



sales@sealey.co.uk



www.sealey.co.uk

Parts Information:
**Electromig Electronic MIG Welder 195Amp
 230V**
Model No: ELECTROMIG195.V3

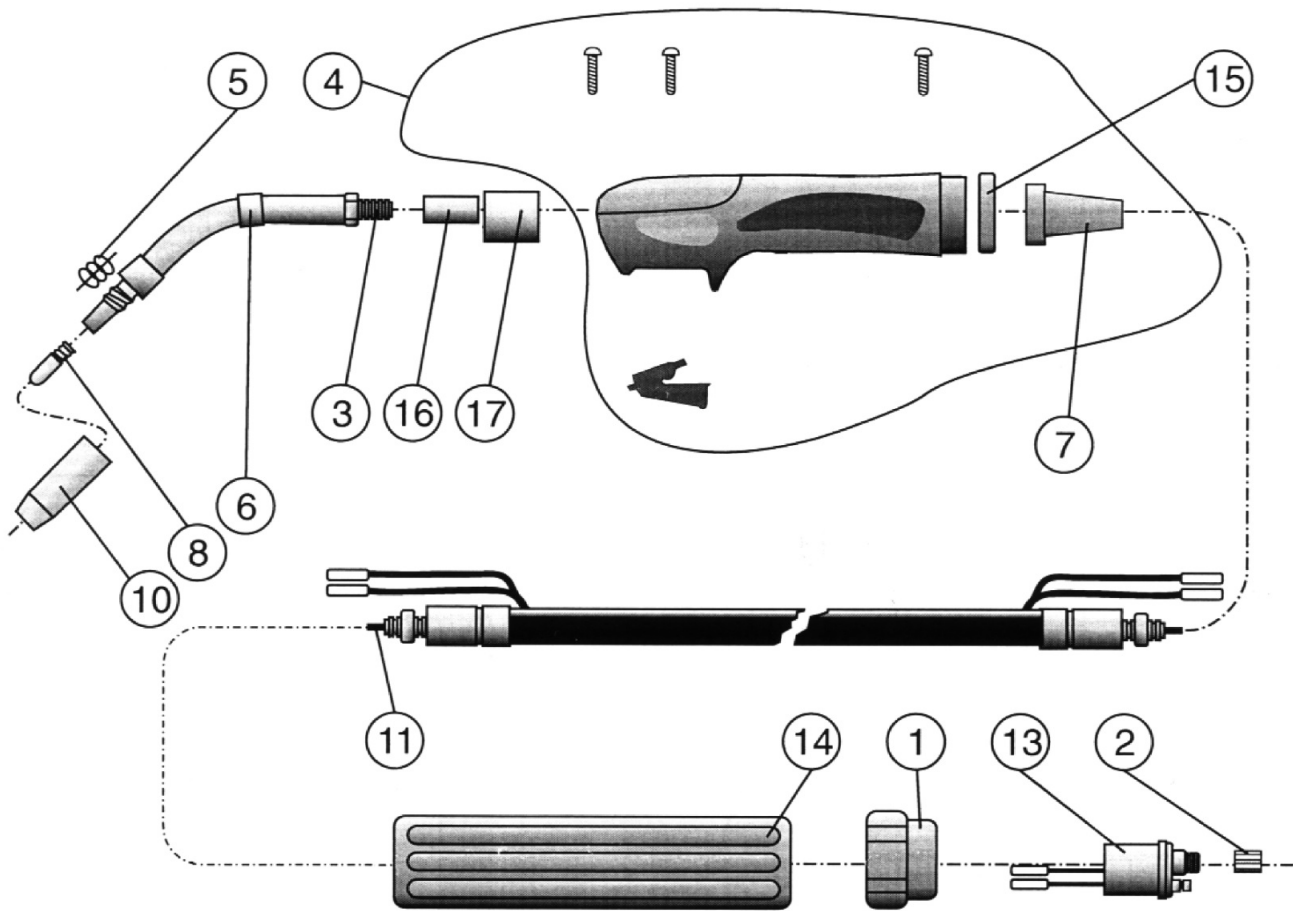

Item	Part No.	Description
1	120/722007	Adaptor nut for ac 305145 / Adaptor nut for ac 305145
2	120/722013	Liner positioner nut for ca 305315 / Liner positioner nut
3	120/722305	Tr-15 swanneck / Tr-15 swanneck
4	120/742170	Handle without switch (with trigger) / Handle without switch
5	120/722319	Spring for Nozzle TB15 / Spring for Nozzle TB15
6	120/722326	Head insulator tr-15 swanneck 305240 / Head insulator tr-15
7	120/742172	Torch holder / Torch holder
8	MIG956	Contact Tip 0.6mm TB15 Pack of 5 / Contact Tip 0.6mm TB15 Pa
8	120/722416	Contact tip tr-15 m6-06-0.8mm
8	120/722553	Contact tip tr-25 m6-08-1.2a 100223 / Contact tip tr-25 m6-0
8	120/722556	Contact tip tr-25 m6-08-0.8a 100217(aluminium) / Contact tip

Item	Part No.	Description
10	168.200105	Cylindrical Nozzle TB15 Single (formerly 120/722149) / Cylin
10	MIG955	Conical Nozzle TB15 Pack of 3 / Conical Nozzle TB15 Pack of
11	168.301535	Blue steel liner, dia 1,5/4,5mm round / Blue steel liner, di
11	120/722689	Liner,t, 1.0-1.2mm 3mt steel / Liner,t, 1.0-1.2mm 3mt steel
13	120/722441	Central adaptor kz2 for 15/25/36 305300 / Central adaptor
14	120/742175	Gun plug housing / Gun plug housing
15	120/742171	Ring nut / Ring nut
16	120/722325	Front torch part / Front torch part
17	120/722693	Plastic body for swanneck 305500 / Plastic body for swanneck
--	120/742174	Spring / Spring (NOT SHOWN)

NOTE: It is our policy to continually improve products and as such we reserve the right to alter data, specifications and component parts without prior notice.

IMPORTANT: No liability is accepted for incorrect use of product.

WARRANTY: Guarantee is 12 months from purchase date, proof of which will be required for any claim.



Parts Information:
**Electromig Electronic MIG Welder 195Amp
 230V**
Model No: ELECTROMIG195.V3

WIRING:

In order to find the diagram corresponding to your model, check the last number ./.X. of the serial number (N.0000/X) printed on front panel

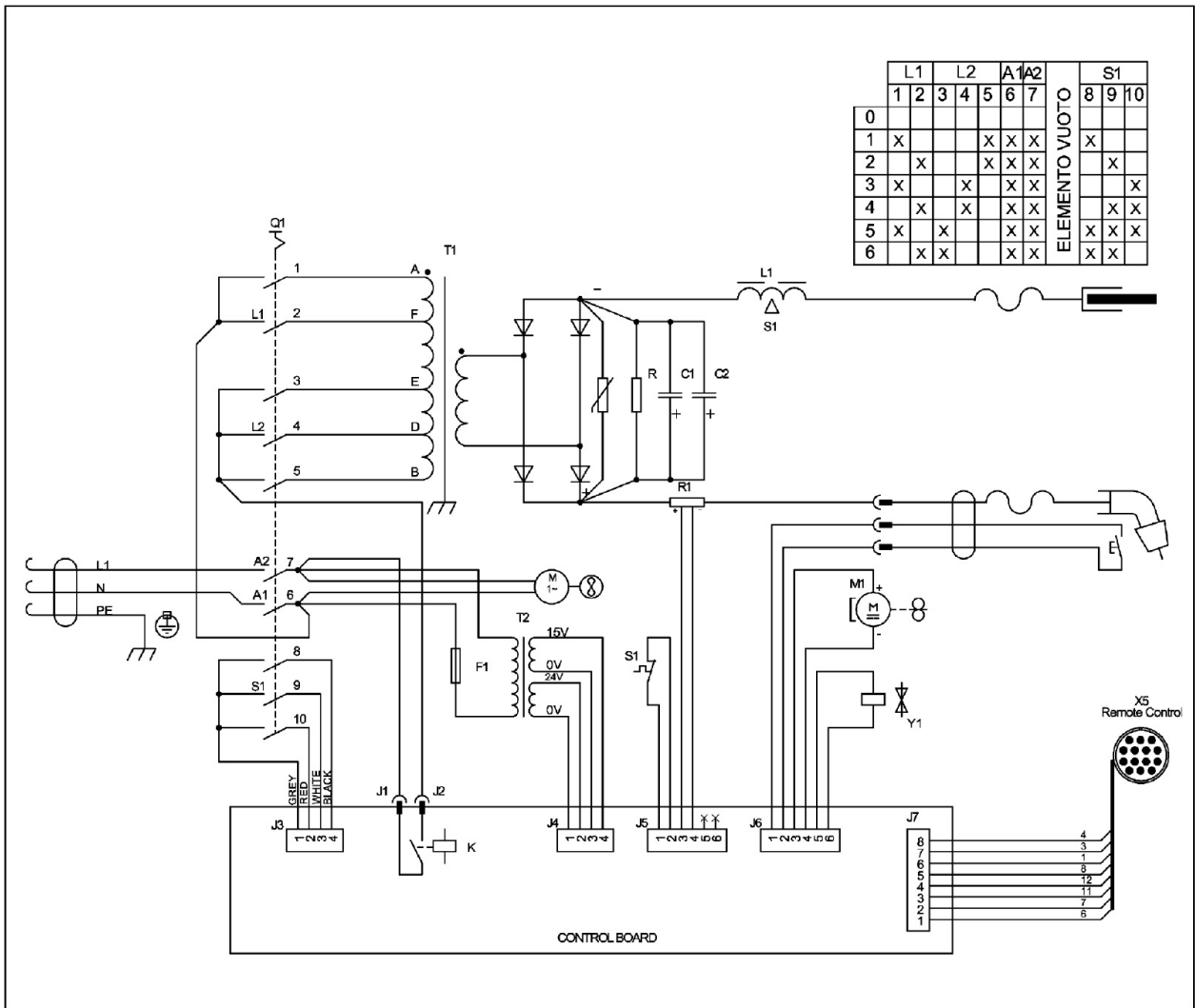

NOTE: It is our policy to continually improve products and as such we reserve the right to alter data, specifications and component parts without prior notice.

IMPORTANT: No liability is accepted for incorrect use of product.

WARRANTY: Guarantee is 12 months from purchase date, proof of which will be required for any claim.

Sealey Group, Kempson Way, Suffolk Business Park, Bury St Edmunds, Suffolk. IP32 7AR



01284 757500



01284 703534



sales@sealey.co.uk



www.sealey.co.uk