

Issue: 2
Date Issued: 20/05/2009

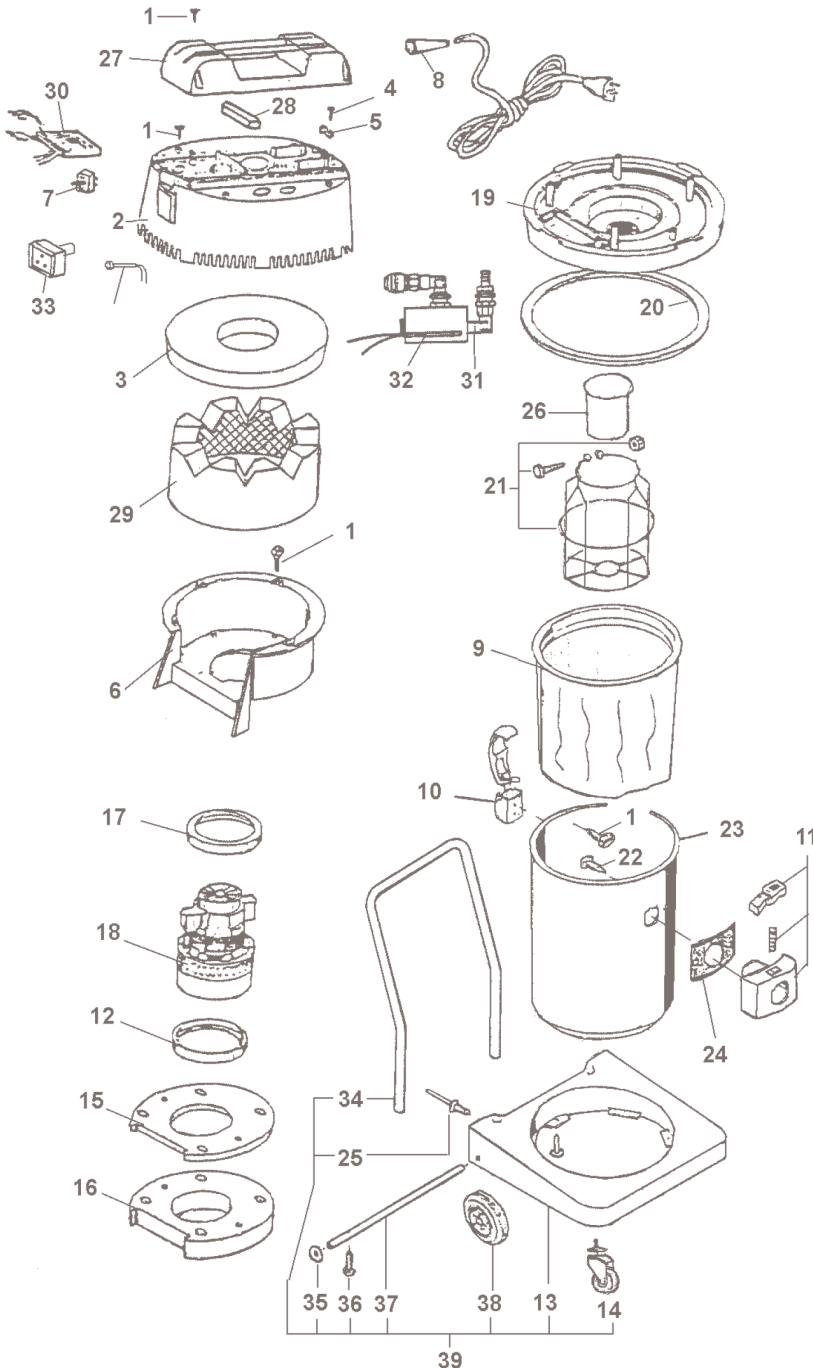

ITEM	PART NO	DESCRIPTION
1	122/02508570	Screw, 5 x 16mm
2	122/02206300	Top cover
3	122/03000071	Silencer, Motor
4	122/02508500	Screw, 2.9 x 19mm
5	122/02001340	Cable Grip
6	122/02200907	Motor Cover, Middle
7	122/34.03.75	Switch, Manual / Automatic
8	122/02502000	Cable Sleeve
9	122/06730000	Complete Filter
10	122/06100002	Clip, Bin
11	122/06000205	Hose Inlet (I/D 50mm)
12	122/02502533	Gasket, Motor lower
13	122/06003300	Base, Trolley
14	122/02510155	Castor Wheel
15	122/03000073	Silencer, Motor base, Upper
16	122/03000072	Silencer, Motor base Lower
17	122/02502531	Gasket, Motor Upper
18	122/02505440	Motor 1200W (3A210)
19	122/02206250	Motor Cover, Lower
20	122/02502405	Gasket, Motor base
21	122/06000505	Float Cage Complete
22	122/02508591	Screw, 5 x 22mm
23	122/02206800	Tank
24	122/02502550	Gasket, Hose Inlet
25	122/02508830	Rivet
26	122/06101100	Float
27	122/02206001	Handle
28	122/03000051	Protection
29	122/03000070	Silencer, Round
30	122/98.03.25	Electronic Card
31	122/99.03.99	Electro-pneumatic Valve
32	122/99.03.09	Reed Switch, Valve
33	122/34.02.01	Socket Complete
34	122/02504290	Handle Trolley
35	122/02510031	Washer, Starlock Ø20mm
36	122/02508592	Screw, 4.8 x 32mm
37	122/02504315	Axle, Fixed Wheels
38	122/02510018	Fixed Wheel, Ø160mm
39	122/06000310	Trolley Complete
40	122/74.01.26	Stand By Lamp (Not Shown)

NOTE: It is our policy to continually improve products and as such we reserve the right to alter data, specifications and component parts without prior notice.

IMPORTANT: No liability is accepted for incorrect use of product.

WARRANTY: Guarantee is 12 months from purchase date, proof of which will be required for any claim.

INFORMATION: For a copy of our latest catalogue and promotions call us on 01284 757525 and leave your full name and address, including postcode.