

Parts Information:
**Dust-Free System with MA150AS 2 x Air/
 Electric**
Model No: DFS23A

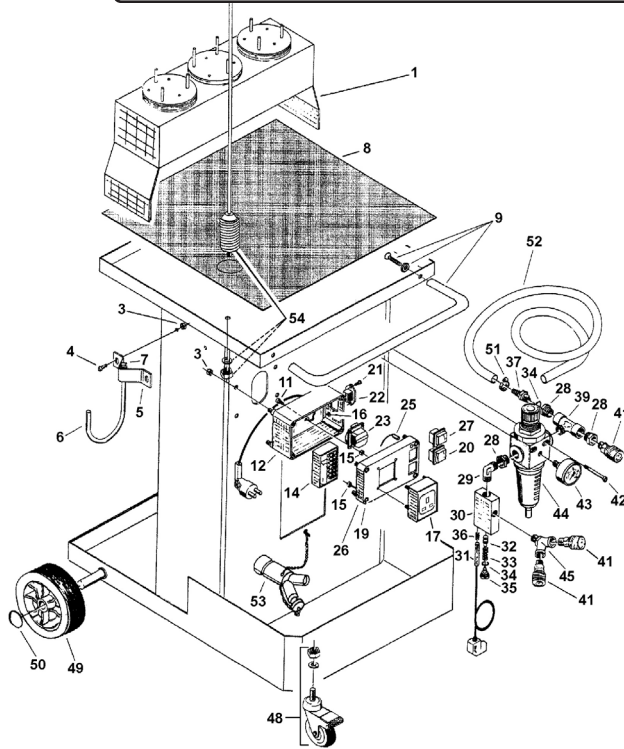

Item	Part No.	Description
--	MA150AS	Air Operated Random/Orbital Sander 150mm Dust/Oil Free (NOT SHOWN)
1	122/71.03.00	Disc Dispenser
3	122/29.01.12	Nut
4	122/11.04.10	Screw
5	122/27.02.60	Bracket
6	122/27.04.06	Hook
7	122/23.01.40	Pin
8	122/27.05.15	Rubber Sheet
9	122/10.15.10	Handle Complete
11	122/11.09.14	Screw
12	122/74.01.14	Housing
14	122/98.03.40	Electronic Card
15	122/21.04.10	Protection Plug
16	122/21.02.20	Lock
17	122/34.02.01	Socket Complete
19	122/74.01.16	Screw
20	122/34.06.77	Switch (Red)
21	122/11.09.03	RD Head S/T Screw M2.8 x 9 Black
22	122/34.02.48	Valve Socket
23	122/34.02.02	Socket
25	122/74.01.17	Led Indicator
26	122/74.01.15	Cover
27	122/34.03.75	Switch Manual/Automatic

Item	Part No.	Description
28	122/97.41.43	Reducer 1/2"m - 3/8" F
29	122/97.43.17	3/8" Elbow M-M
30	122/10.05.30	Valve Body
31	122/99.03.01	Magnetic Switch Complete With Plug
32	122/99.03.12	Valve Piston
33	122/99.03.11	Spring For Valve
34	122/17.01.50	O-Ring
35	122/21.50.05	Valve Plug
36	122/99.03.03	Spring
37	122/97.32.58	Hose Inlet 3/8"M
39	122/97.43.43	Connection 1/2" F,F,M
41	122/97.08.03U	Tap 3/8" Universal
42	122/11.06.12	Screw
43	122/98.02.05	Gauge 170psi, 50mm OD, Rear Fitting
44	122/98.01.20	Pressure Regulator 1/2"
45	122/97.43.22	Connection 3/8" M,F,F
48	122/99.15.55	Castor Ass'y 75x31x5 (W/Brake)
49	122/99.15.50	Wheel
50	122/13.20.22	Axle Cap
51	122/24.50.12	Hose Clip
52	122/66.01.54	Hose 13/19 5 Mtr
53	122/36.01.39	Vac Double Suction Adaptor
54	122/25.02.40	Suction Tube Support Pole

NOTE: It is our policy to continually improve products and as such we reserve the right to alter data, specifications and component parts without prior notice.

IMPORTANT: No liability is accepted for incorrect use of product.

WARRANTY: Guarantee is 12 months from purchase date, proof of which will be required for any claim.



Parts Information:
**Dust-Free System with MA150AS 2 x Air/
 Electric**
Model No: DFS23A

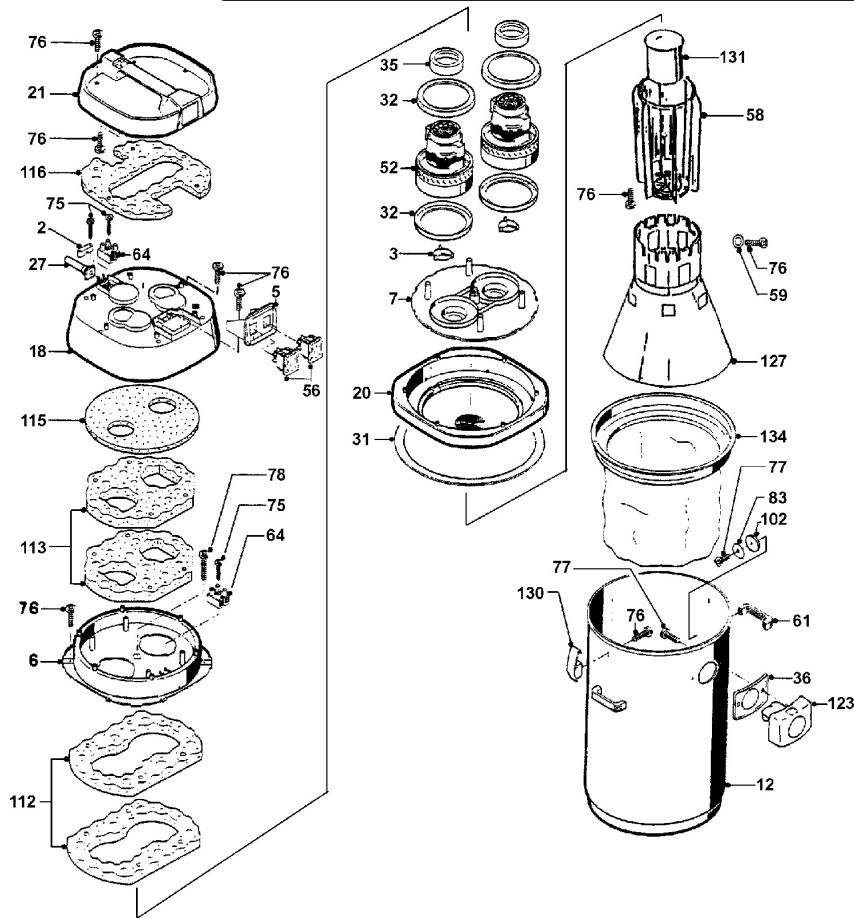

Item	Part No.	Description
2	122/02001340	Strain Relief
3	122/02001360	Motor Switch Valve
5	122/02009250	Switch Plate
6	122/02009300	Motor Housing Upper
7	122/02009310	Motor Housing Lower
12	122/02207020	Plastic Bin
18	122/06003340	Motor Cover Yellow
20	122/02209804	Motor Base Grey
21	122/04075004	Handle Grey
27	122/02502000	Cable Protection
31	122/02502410	Bin Seal
32	122/02502500	Motor Gasket
35	122/02502518	Gasket
36	122/02502550	Intake Gasket
52	122/02505100	Motor 1000 Watt (A40)
56	122/34.06.77	Switch (Red)
58	122.2000090	Floater Cage
59	122/02509030	Galvanized Washer
61	122/02506350	Handle

Item	Part No.	Description
64	122/02506470	Block
75	122/02508500	Screw
76	122/02508570	RD Head S/T Screw M5x15
77	122/02508591	Screw
78	122/02508592	Screw
83	122/02509030	Galvanized Washer
102	122/03000230	Washer
112	122/03000650	Motor Base Gasket
113	122/03000651	Upper Motor Gasket
115	122/03000653	Motor Cover Gasket
116	122/03000658	Motor Cover/Handle Gasket
123	122/06000205	Hose Inlet Housing
127	122.2000095	Filter Fixing System
130	122/06100014	Bin Clip
131	122/06101100	Complete Float
134	122/06830000	Filter Bag (O.D. 435mm)
--	122/99.70.19	Pack Of 10 Dust Collection Bags (NOT SHOWN)
--	DFS/AK3	Vac Hose 5Mtr x 28mm (NOT SHOWN)
--	DFS/AK2	Combination Air/Vacuum Hose (NOT SHOWN)

NOTE: It is our policy to continually improve products and as such we reserve the right to alter data, specifications and component parts without prior notice.

IMPORTANT: No liability is accepted for incorrect use of product.

WARRANTY: Guarantee is 12 months from purchase date, proof of which will be required for any claim.

Sealey Group, Kempson Way, Suffolk Business Park, Bury St Edmunds, Suffolk. IP32 7AR



01284 757500



01284 703534



sales@sealey.co.uk



www.sealey.co.uk