

NOTE: It is our policy to continually improve products and as such we reserve the right to alter data, specifications and component parts without prior notice.

IMPORTANT: No liability is accepted for incorrect use of product.

WARRANTY: Guarantee is 12 months from purchase date, proof of which will be required for any claim.



Parts Information:
MIG Welder 210Amp 230V Automatic Wire Feed
Model No: AUTOMIG210

Item	Part No.	Description
1	331/01503350	Protection
2	331/10045262N	Handle
3	331/04501014	Chain
4	331/00601060	Wire Feed Motor (Internal 24V)
5	331/19060919	Transformer
6	331/01401024	Solenoid Valve 24V
7	331/02301010	Motor Fan, 240 Volt
--	331/190107A	Fan Blade (NOT SHOWN)
8	331/00901320	Rectifier, Bridge
9	331/190109	Chock Block
10	331/19125240	Auxiliary Transformer
--	331/00801200	Contactora 24V 50/60hz (NOT SHOWN)
14	120.312013	Wire Feed Knob
15	331/01503305	Central Connection
16	331/00704190	Switch (Sch 0305/M215)
--	331/19440611	Power Transformer (NOT SHOWN)
21	331/02201170	Wheel, 168x44x13
22	331/02104017	Cap, Wheel
23	331/02202160	Wheel, Castor, 60x24x10mm
24	331/03401015L	Handle Bracket, Left

Item	Part No.	Description
24	331/03401015R	Handle Bracket, Right
25	331/01001010	Electronic Card
26	331/049030005	Reel
31	331/02110055	Roller,0.8-1.0mm (alu)
34	SN10.S	Steel Nut M10 Zinc Din934(Single)
35	331/0302020Z	Washer
36	331/02110010	Pin,Reel Holder
37	331/02120300	Spring
38	SN8.S	Steel Nut M8 Zinc Din934 (Single)
39	331/02104850	Holder,Reel
41	331/104A405R	Lid
42	331/104A403N	Rear Panel
43	331/104A407R	Side Panel (Red)
45	331/104A406R	Panel,Door
46	331/01702016	Fuse Glass 1.5Amp f1.6 250V 5 x20
47	FWM12.S	Flat Washer M12 Single
--	MIG/T25	MIG Torch 3Mtr Euro Connector TB25 (NOT SHOWN)
--	331/104A401N	Panel,Bottom (NOT SHOWN)
--	331/10040395	Axle id 9mm / od 12mm (NOT SHOWN)
--	331/03404007	Knob For Door (NOT SHOWN)

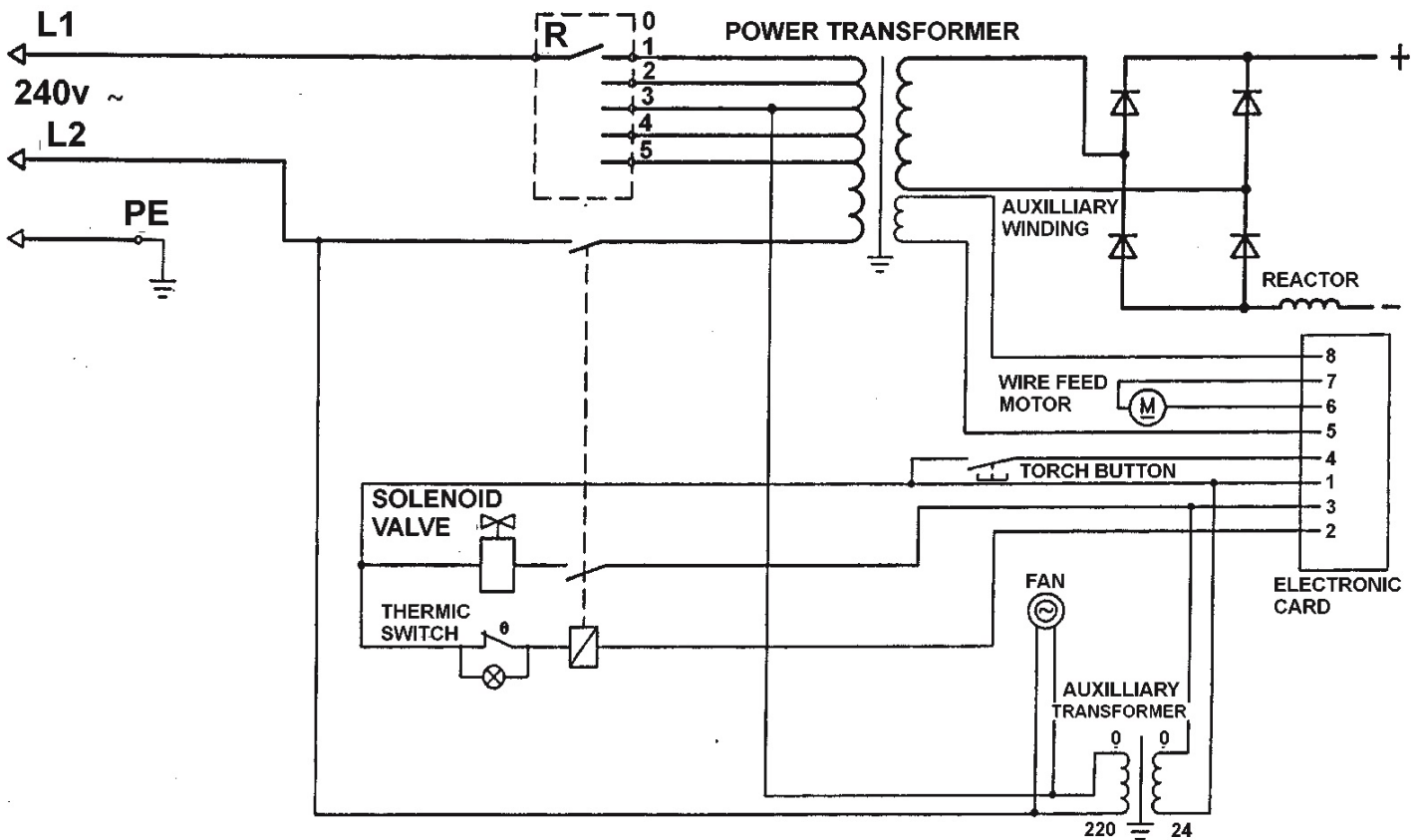

NOTE: It is our policy to continually improve products and as such we reserve the right to alter data, specifications and component parts without prior notice.

IMPORTANT: No liability is accepted for incorrect use of product.

WARRANTY: Guarantee is 12 months from purchase date, proof of which will be required for any claim.

Sealey Group, Kempson Way, Suffolk Business Park, Bury St Edmunds, Suffolk. IP32 7AR



01284 757500



01284 703534



sales@sealey.co.uk



www.sealey.co.uk