

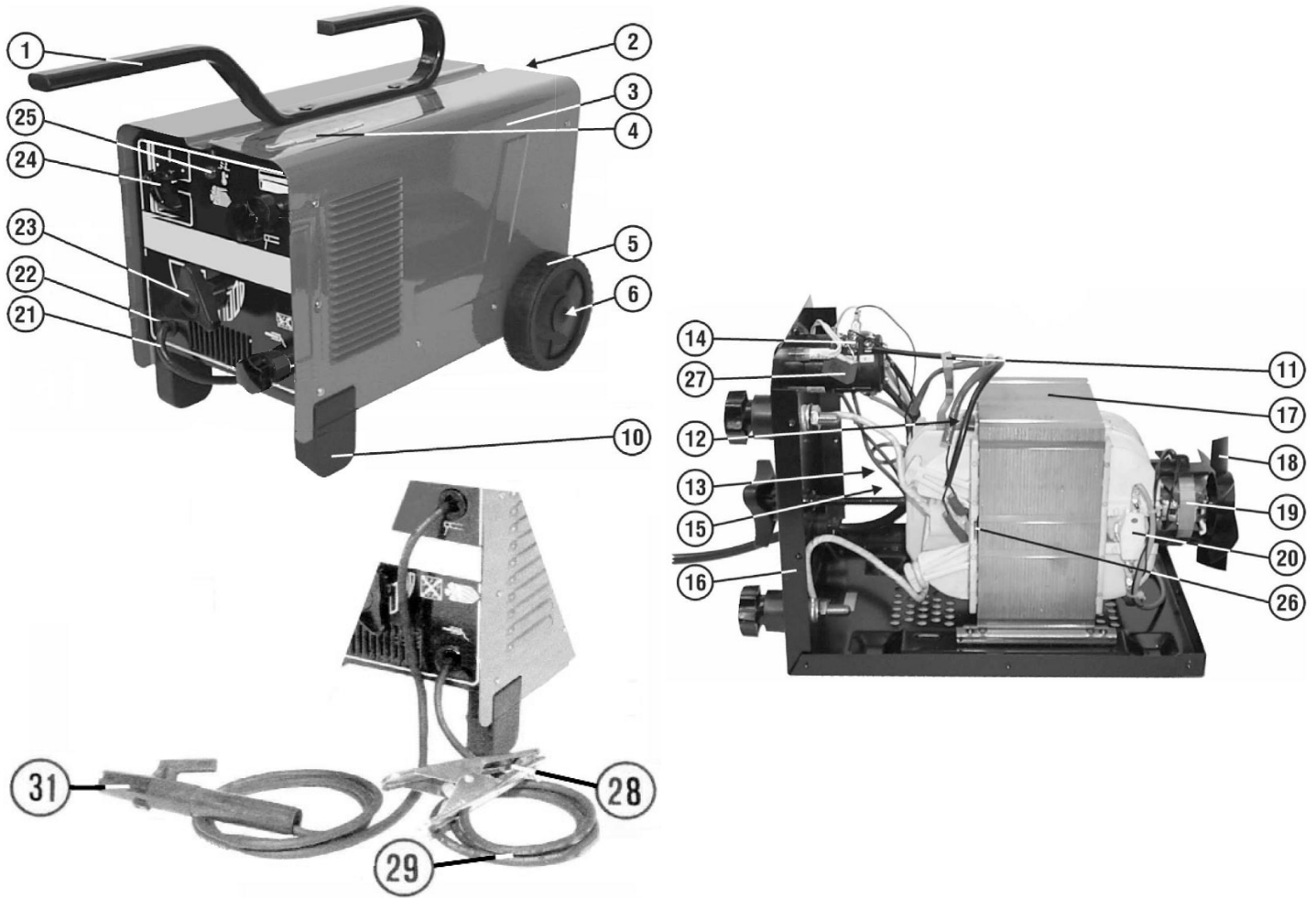

Parts Information:
Arc Welder 200Amp with Accessory Kit
Model No: 200XTC



| Item | Part No. | Description |
|------|------------|----------------------------------------------|
| 1 | 120/645092 | Handle, Carrying |
| 2 | 120/644650 | Panel |
| 3 | 120/655157 | Top Cover |
| 4 | 120/322063 | Transparent Plate |
| 5 | 120/322193 | Wheel |
| 6 | 120/422960 | Axle |
| 10 | 120/322044 | Foot |
| -- | 120/422592 | Regulation Indicator (NOT SHOWN) |
| 11 | 120.322488 | Regulation Indicator (New Version - Plastic) |
| 12 | 120/452092 | Spring |
| 13 | 120/990417 | Shunt Kit |
| 14 | 120.121508 | Switch |
| 15 | 120/422502 | Yoke |
| 16 | 120/649144 | Front Panel |

| Item | Part No. | Description |
|------|------------|-----------------------------|
| 17 | 120/164048 | Transformer |
| 18 | 120/312025 | Blade, Fan |
| 19 | 120/152080 | Motor, Electrofan |
| 20 | 120/122901 | Thermostat |
| 21 | 120/132267 | Mains Cable 3g02.50 2.50m |
| 22 | 120.322112 | Bushing |
| 23 | 120/313017 | Handwheel |
| 24 | 120.323101 | Switch Knob Set |
| 25 | 120/122654 | Pilot Lamp, Slim 250V |
| 26 | 120/452085 | Anti-Vibration Spring |
| 27 | 120/123362 | Capacitor-Resistance |
| 28 | 120/712231 | Work Clamp |
| 29 | CC16/1 | 16mm Copper Cable Per Meter |
| 31 | 120.712260 | Electrode Holder 300A |

NOTE: It is our policy to continually improve products and as such we reserve the right to alter data, specifications and component parts without prior notice.

IMPORTANT: No liability is accepted for incorrect use of product.

WARRANTY: Guarantee is 12 months from purchase date, proof of which will be required for any claim.

Sealey Group, Kempson Way, Suffolk Business Park, Bury St Edmunds, Suffolk. IP32 7AR



01284 757500



01284 703534



sales@sealey.co.uk



www.sealey.co.uk