

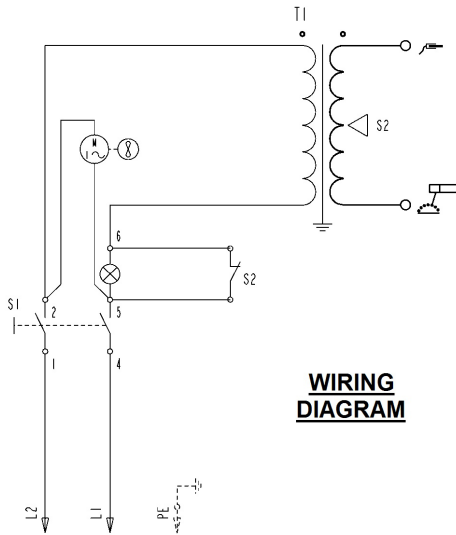

Parts Information:
Arc Welder 150Amp with Accessory Kit
Model No: 150XTC.V2

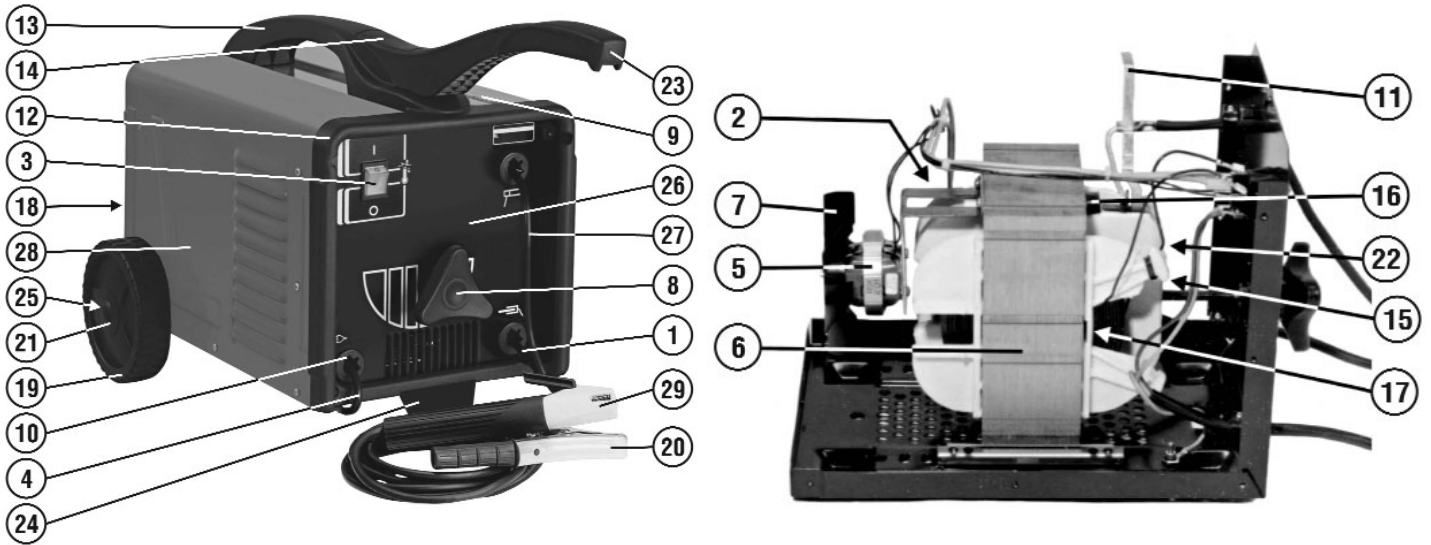

**WIRING
 DIAGRAM**

Item	Part No.	Description
1	CC10/1	10mm Copper Cable Per Metre
2	120/122329	Thermostat
3	120/122752	Switch, Rocker Illuminated
4	MC3CX1.5	Mains Cable blk, 3 core, 1.5mm2
5	120/152080	Motor, Electrofan
6	120/164013	Transformer
7	120/312025	Blade, Fan
8	120/313015	Reel Handwheel
9	120/322063	Transparent Plate
10	120.322112	Bushing
11	120.322488	Regulation Indicator (New Version - Plastic)
12	120.322675	Frame
13	120.322676	Handle
14	120.322681	Cap For Handle
15	120/422502	Yoke

Item	Part No.	Description
16	120/452085	Anti-Vibration Spring
17	120/452092	Spring
18	120/644136	Back Panel
19	120/322193	Wheel
20	120/712001	Clamp, Earth (Black)
21	120/322223	Cap, Axle
22	120/990418	Kit
23	120.322678	Handle
24	120.322679	Foot
25	120.482783	Wheels Axle
26	120.649694	Front Panel
27	120/713031	Cable 10mmq 1,8 m
28	120.990996	Cover Kit
29	120.712260	Electrode Holder 300a

NOTE: It is our policy to continually improve products and as such we reserve the right to alter data, specifications and component parts without prior notice.

IMPORTANT: No liability is accepted for incorrect use of product.

WARRANTY: Guarantee is 12 months from purchase date, proof of which will be required for any claim.

Sealey Group, Kempson Way, Suffolk Business Park, Bury St Edmunds, Suffolk. IP32 7AR



01284 757500



01284 703534



sales@sealey.co.uk



www.sealey.co.uk