

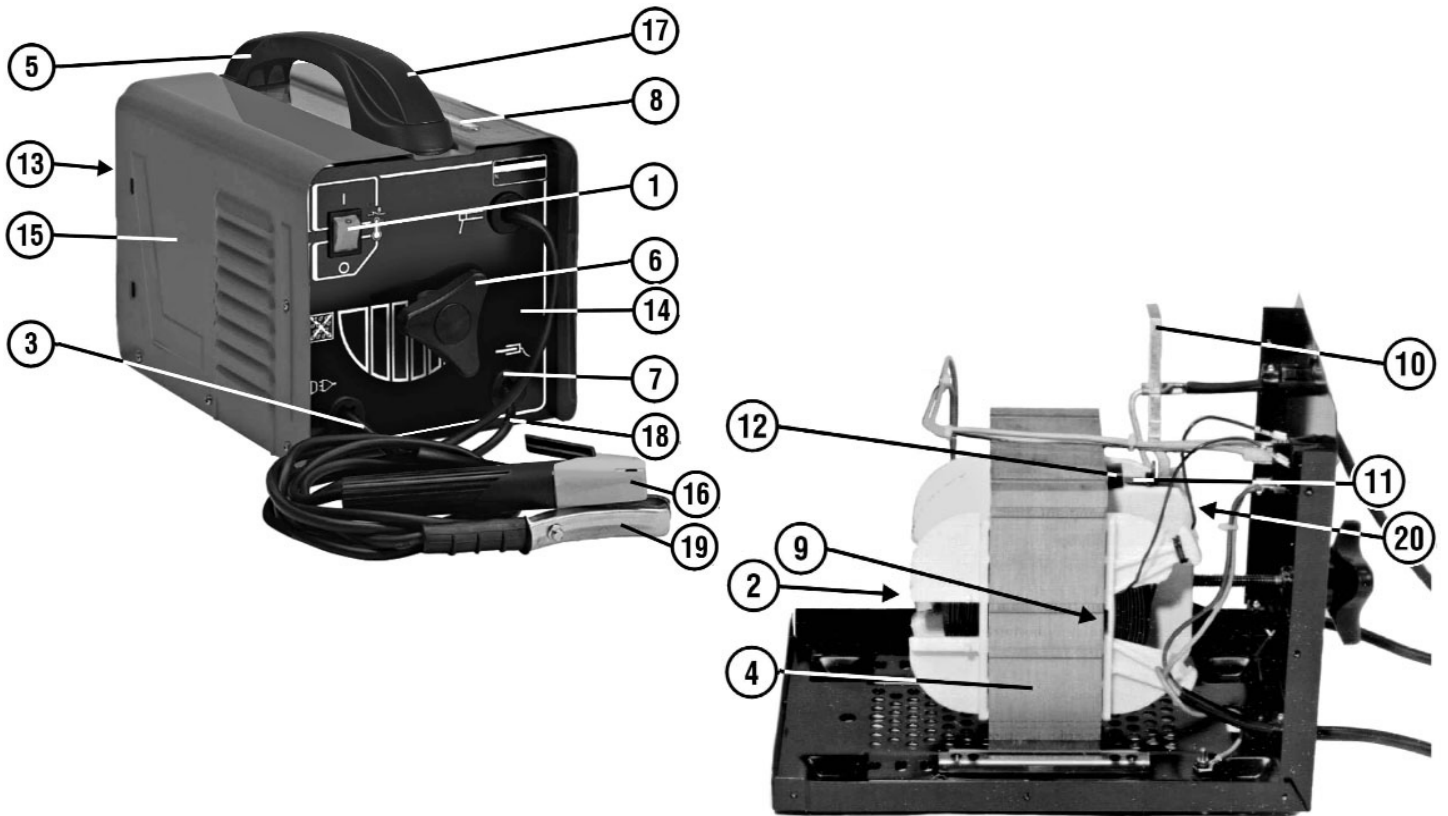

Parts Information:
Arc Welder 150Amp with Accessory Kit
Model No: 150XL.V2

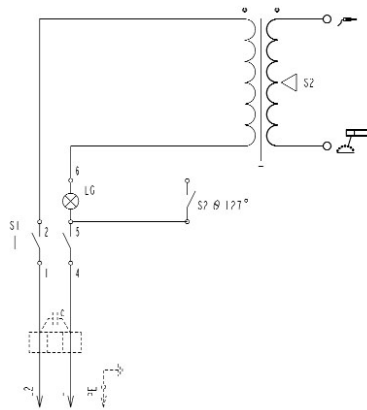

WIRING DIAGRAM



Item	Part No.	Description
1	120/122752	Switch, Rocker Illuminated
2	120/122329	Thermostat
3	120/132169	Mains Cable 3g1.5 2.3m
4	120/164013	Transformer
5	120.322676	Handle
6	120/313015	Reel Handwheel
7	120.322112	Bushing
8	120/322076	Plate
9	120/452092	Spring
10	120/322445	Regulation Indicator

Item	Part No.	Description
11	120/990418	Kit
12	120/452085	Anti-Vibration Spring
13	120/644135	Panel
14	120.649703	Front Panel
15	120.980007	Cover Kit
16	120/713031	Cable 10mmq 1,8 m
17	120.322681	Cap For Handle
18	CC10/1	10mm Copper Cable Per Metre
19	120/712001	Clamp, Earth (Black)
20	120/422502	Yoke

NOTE: It is our policy to continually improve products and as such we reserve the right to alter data, specifications and component parts without prior notice.

IMPORTANT: No liability is accepted for incorrect use of product.

WARRANTY: Guarantee is 12 months from purchase date, proof of which will be required for any claim.

Sealey Group, Kempson Way, Suffolk Business Park, Bury St Edmunds, Suffolk. IP32 7AR



01284 757500



01284 703534



sales@sealey.co.uk



www.sealey.co.uk