

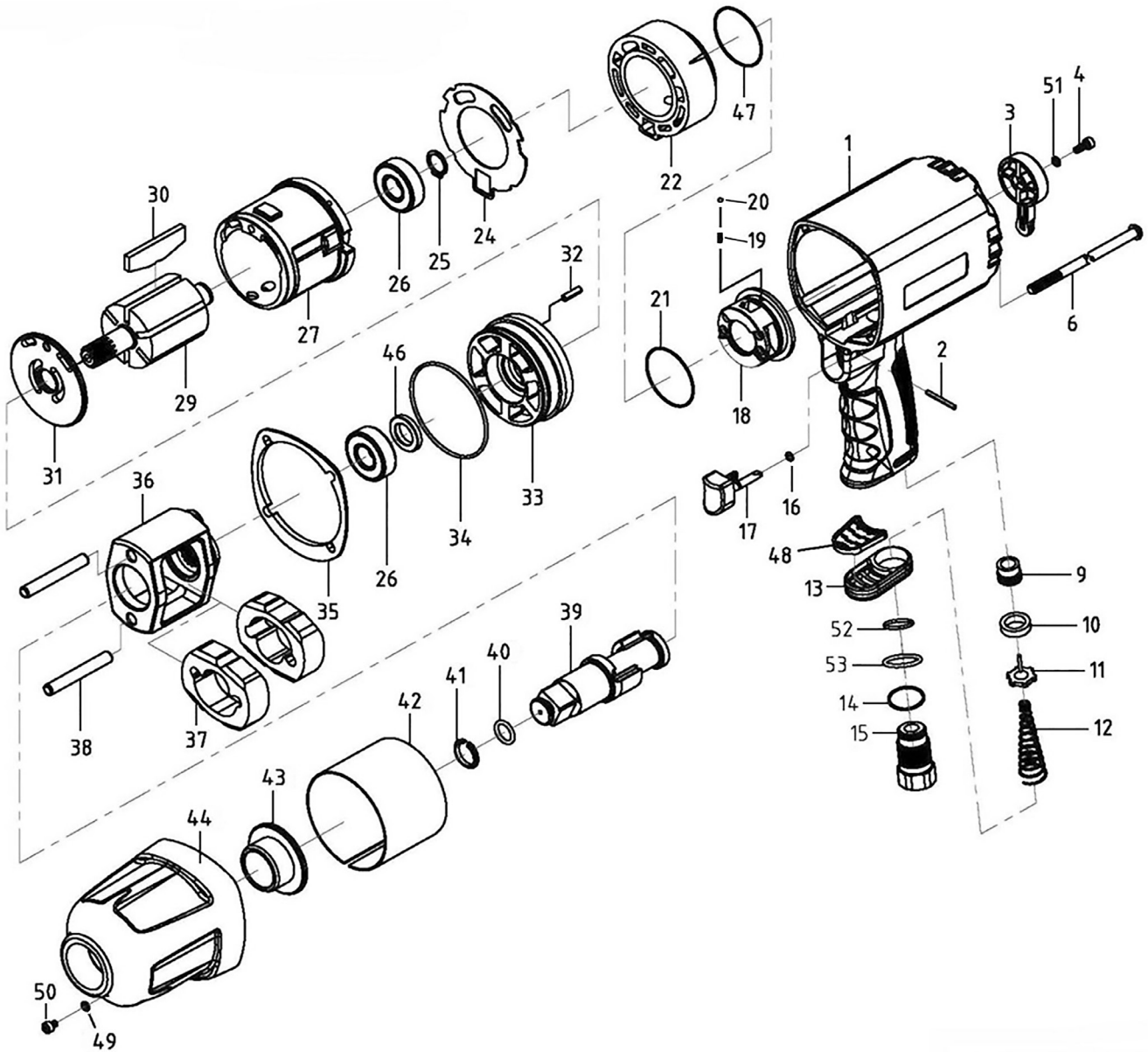

Parts Information:
**Composite Air Impact Wrench 3/4" Sq
 Drive - Twin Hammer**
Model No: GSA6004



Item	Part No.	Description
1	GSA6004.01	Housing
2	GSA01.05	Spring Pin M2.6 X 22
3	GSA6004.03	Lever, Forward/Reverse
4	SCB410.SB	Socket Cap Bolt M4 x 10mm Black
6	GSA6004.06	Button Head Torx Screw M6x114
9	GSA6004.09	Lock Screw
10	GSA6004.10	Valve Seat
11	GSA6004.11	Valve
12	GSA6004.12	Valve Spring Conical

Item	Part No.	Description
13	GSA6004.13	Exhaust Deflector
14	GSA6004.14	Seal Ring Washer
15	GSA6004.15	Air Inlet
16	GSA6004.16	O-Ring, (Ex: 4.82 In: 2.79 Cs: 1.02)
17	GSA6004.17	Trigger
18	GSA6004.18	Air Regulator
19	GSA6004.19	Spring Dia 2.4mm
20	SB-2.5	Steel ball 2.5mm
21	GSA6004.21	O-ring, (Ex: 40.81 In: 38.13 Cs: 1.34)

NOTE: It is our policy to continually improve products and as such we reserve the right to alter data, specifications and component parts without prior notice. There may be alternative versions of this product, please contact us should you require this information.

IMPORTANT: No liability is accepted for incorrect use of product. Spare parts must be fitted by a competent person

WARRANTY: Guarantee is 12 months from purchase date, proof of which will be required for any claim.

Sealey Group, Kempson Way, Suffolk Business Park, Bury St Edmunds, Suffolk. IP32 7AR



01284 757500



sales@sealey.co.uk



www.sealey.co.uk



Parts Information:
**Composite Air Impact Wrench 3/4" Sq
Drive - Twin Hammer
Model No: GSA6004**

Item	Part No.	Description
22	GSA6004.22	Valve Seat
24	GSA6004.24	Gasket
25	SA58.V2-17	External Circlip 19.4mm ID.
26	B/6003Z	Bearing 6003Z
27	GSA6004.27	Cylinder
29	GSA6004.29	Rotor
30	GSA6004.30	Rotor Blade
31	GSA6004.31	Plate
32	SA604/12	Spring Pin M4 X 14
33	GSA6004.33	Front End Plate
34	GSA6004.34	O-ring, (Ex: 63.61 In: 60.05 Cs: 1.78)
35	GSA6004.35	Gasket
36	GSA6004.36	Hammer Cage
37	GSA6004.37	Hammer Dog
38	GSA6004.38	Hammer Pin

Item	Part No.	Description
39	GSA6004.39	Anvil
40	GSA6004.40	O-Ring, (Ex: 14.87 In: 9.93 Cs: 2.47)
41	GSA6004.41	Retainer
42	GSA6004.42	Sleeve
43	GSA6004.43	Anvil Bushing
44	GSA6004.44	Hammer Case
46	GSA6004.46	Oil Seal
47	GSA6004.47	Gasket
48	GSA6004.48	Muffler Cover
49	GSA6004.49	O-ring, (Ex: 4.86 In: 3.09 Cs: 0.89)
50	SCB510.SB	Socket Cap Bolt M5 x 10mm Black
51	FWM4.SB	Flat Washer M4 Black
52	GSA6004.52	O-Ring, (Ex: 19.60 In: 15.60 Cs: 1.78)
53	GSA6004.53	Seal

NOTE: It is our policy to continually improve products and as such we reserve the right to alter data, specifications and component parts without prior notice. There may be alternative versions of this product, please contact us should you require this information.

IMPORTANT: No liability is accepted for incorrect use of product. Spare parts must be fitted by a competent person

WARRANTY: Guarantee is 12 months from purchase date, proof of which will be required for any claim.

Sealey Group, Kempson Way, Suffolk Business Park, Bury St Edmunds, Suffolk. IP32 7AR



01284 757500



sales@sealey.co.uk



www.sealey.co.uk