



INSTRUCTIONS FOR: HYDRAULIC BENCH & FLOOR PRESS

FLOOR Models: YK15.V3, YK15FM.V3, YK30.V3, YK30FM.V3, YK50FM.V3.
BENCH Models: YK10BM.V3, YK15BM.V3.

Thank you for purchasing a Sealey product. Manufactured to a high standard this product will, if used according to these instructions and properly maintained, give you years of trouble free performance.

⚠ IMPORTANT: PLEASE READ THESE INSTRUCTIONS CAREFULLY. NOTE THE SAFE OPERATIONAL REQUIREMENTS, WARNINGS AND CAUTIONS. USE THIS PRODUCT CORRECTLY AND WITH CARE FOR THE PURPOSE FOR WHICH IT IS INTENDED. FAILURE TO DO SO MAY CAUSE DAMAGE OR PERSONAL INJURY, AND WILL INVALIDATE THE WARRANTY. PLEASE KEEP INSTRUCTIONS SAFE FOR FUTURE USE.

1. SAFETY INSTRUCTIONS

1.1 GENERAL SAFETY

- ✓ Familiarise yourself with this products application and limitations, as well as the specific potential hazards peculiar to the press.
- ✓ Maintain the press in good condition (use an authorised service agent).
- ✓ Replace or repair damaged parts. *Use recommended parts only. Unauthorised parts may be dangerous and will invalidate the warranty.*
- ✓ Keep the press clean for best and safest performance.
- ✓ Locate the press in an adequate working area for its function, keep area clean and tidy and free from unrelated materials, and ensure there is adequate lighting.
- ✓ Ensure the workpiece is correctly secured before operating the press.
- ☐ **WARNING!** Always wear approved eye or face protection when operating the press.
- ✓ Remove ill fitting clothing. Remove ties, watches, rings, loose jewellery and contain long hair.
- ✓ Keep hands and body clear of the work table when operating the press.
- ✓ Maintain correct balance and footing. Ensure the floor is not slippery and wear non-slip shoes.
- ✓ Keep children and unauthorised persons away from the working area.
- ✗ **DO NOT** operate the press if any parts are missing as this may cause failure and/or possible personal injury.
- ✗ **DO NOT** force the press to achieve a task it was not designed to perform.
- ✗ **DO NOT** adjust or tamper with the safety valve.
- ✗ **DO NOT** exceed the rated capacity of the press.
- ✗ **DO NOT** apply off centre loads.
- ✗ **DO NOT** allow the workpiece or the arbor plates to fall from the press working bench.
- ✗ **DO NOT** get the press wet or use in damp or wet locations or areas where there is condensation.
- ✗ **DO NOT** operate the press when you are tired, under the influence of alcohol, drugs or intoxicating medication.
- ✓ When not in use release pressure from the pump and clean the press. Stand or store the arbors in a safe location.
- ☐ **WARNING!** When moving the table position please observe safe handling practices.
- ☐ **WARNING!** Always position the press against a wall. If the press is situated in the open workshop, it is essential that a guard be placed at the rear of the unit. This will prevent injury to bystanders in the event of the work piece ejecting suddenly.
- ▲ **DANGER!** The press is top heavy. If it requires moving after assembly or for relocation, use suitable slings around the top crossbeam, or lift direct with a forklift with the forks located under the top crossbeam. **DO NOT** use a pallet truck.

2. INTRODUCTION & SPECIFICATIONS

2.1 GENERAL INFORMATION

The Sealey range of heavy duty floor and bench hydraulic presses are ideal for a variety of workshop applications and are particularly suited to agricultural or industrial use. Jobs such as straightening, bending, folding, punching, removing bolts and bearings etc are some of tasks that may be accomplished by your press. All models are fitted with pressure gauge and work-table V-blocks except where stated. The "BM" and "FM" range of press units feature integrally mounted rams giving more vertical clearance between the table and ram head enabling larger items to be fitted on the working table.

☐ **WARNING!** All models are purpose designed to withstand greater loads than the hydraulic units can develop. For safety reasons, always ensure the workpiece is secured on table and loads that flex will not suddenly "give" causing danger to operator or damage to component.

Model:	YK10BM.V3	YK15BM.V3	YK15.V3	YK15FM.V3	YK30.V3	YK30FM.V3	YK50FM.V3
Capacity	10T	15T	15T	15T	30T	30T	50T
Ram Stroke	135mm	95mm	150mm	95mm	150mm	120mm	120mm
Extension Screw	n/a	75mm	75mm	75mm	75mm	75mm	75mm
Max Ht-Ram to Table	460mm	450mm	660mm	660mm	680mm	690mm	715mm
Min Ht-Ram to Table	160mm	150mm	150mm	150mm	150mm	155mm	155mm
Table Aperture	140mm	140mm	140mm	140mm	170mm	170mm	170mm
Work Table Depth	155mm	155mm	155mm	155mm	190mm	190mm	190mm
Work Table Width	500mm	500mm	500mm	500mm	550mm	550mm	550mm
Overall Height	1125mm	1050mm	1775mm	1750mm	1850mm	1915mm	1910mm
Gauge Included	yes	yes	yes	yes	yes	yes	yes
Weight	71kg	74kg	81kg	86kg	158kg	135kg	214kg

3. ASSEMBLY & INSTALLATION

Unpack product and check contents against list below. Should there be any damaged or missing parts contact your supplier immediately. Take care to ensure safety when removing main frame from packing as the unit is very heavy. Retain pressure gauge in carton until required, and do not remove white tape from gauge mount or masking tape from the angle arm.

- Contents:**
- ✓ Frame ✓ Legs x2 ✓ Worktable x1 ✓ Worktable pins x2 ✓ V-blocks x2 ✓ Pump handle x1 ✓ Pressure gauge + Adaptor x1
 - ✓ Gauge angle arm connector x1 ✓ Winch Handle (50ton models only).

3.1 PRESS ASSEMBLY (refer to the appropriate parts diagram as a guide to assembly)

- 3.1.1 Identify and lay out parts. Handle the main frame with care and lay horizontally allowing the cross legs to be bolted on to the bottom of the pre-assembled main frame. **Note:** Care must be taken when handling the main frame to ensure stability. **DO NOT** allow to fall.
- 3.1.2 Locate the pressure gauge inlet hole in the head of the press hydraulic system and remove the dust plug with a hex key, (this may be very tightly secured).
Screw the gauge adaptor tightly into this hole, now screw the gauge into the adaptor, ensuring that the gauge comes to rest in an upright position for ease of reading.
- 3.1.3 Securely attach the press to a flat, firm, level surface taking into account clearance for working pieces. Should you wish to mount a bench press on a workbench or surface, ensure the bench is flat and level and is strong enough to support the press and any workpiece during operation.
- ▲ **DANGER! The press is top heavy.** If it requires moving after assembly or for relocation, use suitable slings around the top crossbeam, or lift direct with a forklift with the forks located under the top crossbeam. **DO NOT** use a pallet truck.
- 3.1.4 Once installed, screw the pump handle into the pump arm.
- 3.1.5 Insert the work table pins through holes in the main frame and carefully place the work table between the frame uprights, lowering it onto the pins accordingly.
- WARNING!** Observe 'safe handling practices' by using two people to position the table.
- WARNING!** Take care not to allow the working table to drop onto the pins and ensure your hands and fingers are clear of the working table when lowered.
- 3.1.6 Place v-blocks on work table ready for use. Take care to ensure the v-blocks do not fall from the work table.
- 3.1.7 Purge hydraulic system.
Before operating the press, purge the hydraulic system in order to eliminate any air that may have built up during transit. Open the release valve and pump the handle several times. Should the system malfunction at any time, repeating this process may resolve the problem.

4. OPERATION

- ▲ **DANGER! Models are purpose designed to withstand greater loads than the hydraulic units can develop. For safety reasons, always ensure the workpiece is secured on table and loads that flex will not suddenly "give" causing danger to operator or damage to component. Also ensure you have read and understood chapter 1 safety instructions.**

4.1 OPERATING INSTRUCTIONS.

- 4.1.1 Using press adjustable table support pins place the press working table at the required operating height.
- WARNING!** Observe 'safe handling practices' by using two people to position the table.
- 4.1.2 Check that the hydraulic unit is fully closed ready for operating.
- 4.1.3 Place workpiece onto the work table or the two arbors appropriately positioned. Position the head of the hydraulic unit on the centre of the workpiece using appropriate extension. **Note:** Care must be taken to ensure an arbor does not fall from the press worktable.
- 4.1.4 **DO NOT** exceed the stroke indicated on the label or the red mark on the piston.
- 4.1.5 **DO NOT** apply off centre loads.
- 4.1.6 When work is complete release the pressure and the piston and the ram head will retract automatically.
Note: Always keep the piston, extension screw and pump piston retracted after use.

5. MAINTENANCE

Note: Maintenance and repair must only be carried out by qualified person. Contact your Sealey dealer for details.

- 5.1 Lubricate all moving parts at regular intervals.
- 5.2 Always keep the press clean, dry, and protected from harsh conditions.
- 5.3 Should you need to replace oil ensure piston is fully retracted. An excess of oil will render press inoperative. Use only appropriate Sealey hydraulic oil. **DO NOT** use brake fluid. Contact your local Sealey dealer for details. Purge the system to remove any air.
- 5.4 Check your model parts information for spares. Repair kits are also available.

IMPORTANT: NO RESPONSIBILITY IS ACCEPTED FOR INCORRECT USE OF THE MACHINE.

Hydraulic products are only repaired by local service agents. We have service/repair agents in all parts of the UK.

DO NOT RETURN PRODUCT TO US. Please telephone us on 01284 757500 to obtain the address and phone number of your local agent. If product is under guarantee please contact your dealer.

De-commissioning Product

Should the product become completely unserviceable and require disposal, draw off the oil into an approved container and dispose of the product and the oil according to local regulations.

Declaration of Conformity We, the sole importer into the UK, declare that the products listed below are in conformity with the following standards and directives.

Hydraulic Press Models
YK10BM.V3, YK15.V3, YK15BM.V3,
YK15FM.V3, YK30.V3, YK30FM.V3,
YK50FM.V3.
2006/42/EC Machinery Directive
93/68/EEC CE Marking Directive



The construction files for these products are held by the Manufacturer and may be inspected by a national authority upon request to Jack Sealey Ltd

Signed by Mark Sweetman

Date 2nd December 2008

For Jack Sealey Ltd. Sole importer into the UK of Sealey Quality Machinery

NOTE: It is our policy to continually improve products and as such we reserve the right to alter data, specifications and component parts without prior notice.

IMPORTANT: No liability is accepted for incorrect use of this product.

WARRANTY: Guarantee is 12 months from purchase date, proof of which will be required for any claim.

INFORMATION: Call 01284 757525 for our catalogue & promotions. Leave your full name, address & postcode.



Sole U.K. Distributor
Sealey Group
Bury St. Edmunds
Suffolk.



01284 757500

01284 703534



www.sealey.co.uk

sales@sealey.co.uk

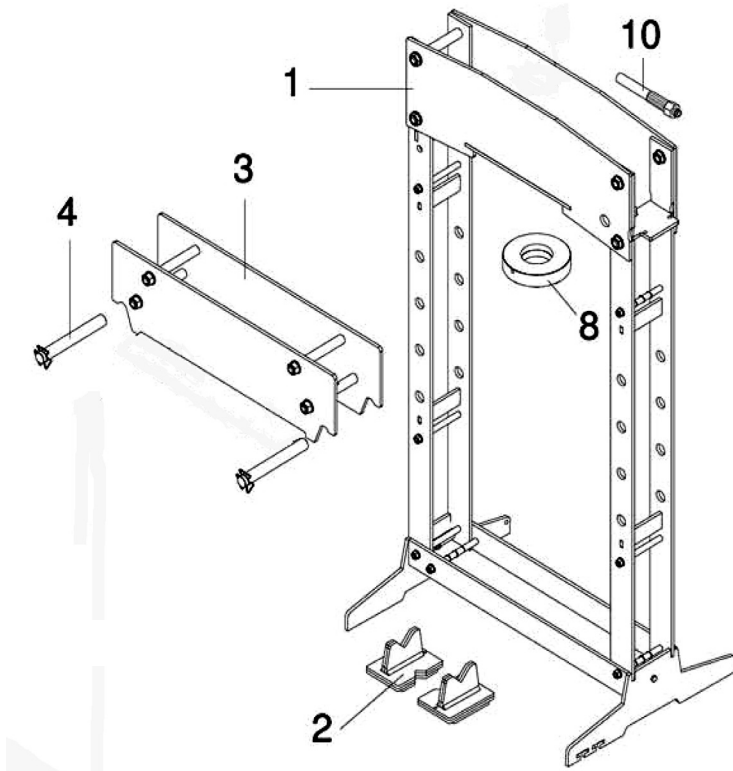

ITEM	PART NO	DESCRIPTION
1	KSC-10A-C1M	FRAME ASS'Y
2	KCK-15AM-C15	V-BLOCK
3	KSC-10AM-C44	TABLE
4	KCK-15AM-C92	TABLE SUPPORT PIN
8	KSCM-10/1508	NUT, RAM RETAINING
10	KSCM-15-1381	PIPE
--	BK-05	HYDRAULIC UNIT (not shown)

ITEM	PART NO	DESCRIPTION
1	BK05-C21M	PUMPING HANDLE
3	BM-04/1125	RELEASE VALVE KNOB
4	MG-2/1130	O-RING
5	ME-1501/1212	LARGE STEEL BALL (7.7mm)
6	ME-1501/1149	SMALL STEEL BALL (5.4mm)
7	MG-2/C9	SAFETY VALVE
8	MG-2/1344	AXLE
9	MB-22-A/1286	CIRCLIP
10	MG-2/1161	CIRCLIP
11	MG-2/1133	SEAL
12	BK-1/C7	HANDLE SOCKET (S)
13	BK-1/1282	CLIP
14	ME-12001/1139	FILLER PLUG
15.1	A-5578	CONNECTOR
16	MB-22-A/1130	O-RING
18.1	Y-2/1160	SCREW
19.1	A-5110	GAUGE WITH REAR FITTING
20	KCK-15/2121	CONNECTOR
21	KSCM-10/1381	PIPE
22 (A)	YK10BM/22	RAM COMPLETE
23	KSCM-10/1674	CIRCLIP
26	ME-10001/1134	SEAL
27	TR-2/1164	SEAL
28	CC-10/1348	SEAL
29	CC-10-B/C14	RAM
30	CC-10/1240	SPRING
31	CC-10/1102	PISTON GUIDE
32	YK10BM/32	RAM SADDLE
33	GN-20/1934	GRUB SCREW
63	RCC-10	REPAIR KIT (for Ram)
	RBKD-09	REPAIR KIT (for Hyd Unit)
B	CC-10-C14M	MAIN PISTON
C	BM04-C11M	RELEASE KNOB ASS'Y
D	BK05-C7M	HANDLE SOCKET ASS'Y

