

MODEL No's	YAJ15-30	YAJ15-30DC	YAJ20-40	YAJ20-40DC	YAJ20-40LR
------------	----------	------------	----------	------------	------------

Thank you for purchasing a Sealey jack. Manufactured to a high standard this product will, if used according to these instructions and properly maintained, give you years of trouble free performance.



**IMPORTANT: READ THESE INSTRUCTIONS CAREFULLY. NOTE THE SAFE OPERATIONAL REQUIREMENTS, WARNINGS AND CAUTIONS. USE THIS JACK CORRECTLY AND WITH CARE FOR THE PURPOSE FOR WHICH IT IS INTENDED. FAILURE TO DO SO MAY CAUSE DAMAGE AND/OR PERSONAL INJURY, AND WILL INVALIDATE THE WARRANTY. RETAIN THESE INSTRUCTIONS FOR FUTURE USE.**

## 1. SAFETY INSTRUCTIONS

- ✓ Disconnect jack from air supply before changing parts, servicing or performing any maintenance.
- ❑ **WARNING!** Ensure correct air pressure is maintained and not exceeded. Recommended pressure 116-145psi or 174psi for YAJ20-40LR. Required air flow 10.5cfm or 11.5cfm for YAJ20-40LR.
- ✓ Keep air hose away from heat, oil and sharp edges. Check air hose for wear before each use, and ensure that all connections are secure.
- ✓ Ensure Jack is kept clean and in good working order. Immediately repair or replace damaged parts.
- ✓ Use recommended parts only. Incorrect parts may be dangerous and will invalidate the warranty.
- ✓ Use a qualified person to lubricate and maintain the jack.  
**DO NOT** use brake fluid to top up system. Use Sealey hydraulic oil only.
- ✓ Locate jack in a suitable, well lit work area. Keep area clean and tidy and free from unrelated materials.
- ✓ Use jack on level & solid ground, preferably concrete. *Avoid tarmac since jack may sink in.*
- ✓ Place wedges under wheels of vehicle (*but ensure wheels of jack can freely move*).
- ✓ Ensure the vehicle handbrake is engaged (or in "PARKED" mode), and switch the engine off.
- ✓ Ensure minimum distance of 0.5m between vehicle tilt & static objects such as doors, walls, etc.
- ✓ Ensure all non essential persons keep a safe distance and that there are no passengers in the vehicle to be jacked up.
- ✓ Place jack under vehicle manufacturer's recommended jacking points (*see vehicle handbook*).
- ✓ Check that the jacking point is stable and centred on the jack saddle and is free from grease or oil.
- ✓ Ensure jack wheels are free to move and that there are no obstructions.
- ▲ **DANGER:** Use jack for lifting only, **NOT** for supporting the raised load. Use correctly rated axle stands under vehicle before proceeding with task.
- X **DO NOT** apply your body weight to the handle during jacking. The handle is only for moving the jack to and from the lifting location.
- X **DO NOT** operate the jack if parts are missing or damaged.
- X **DO NOT** exceed the rated capacity of the jack.
- X **DO NOT** allow the vehicle to move during lifting and do not use the jack to move the vehicle.
- X **DO NOT** jack a vehicle which may result in the spillage of fuel, battery acid, or dangerous substances.
- X **DO NOT** work under the vehicle until Axle Stands have been correctly positioned.
- X **DO NOT** use the jack for purposes other than which it is designed for.
- X **DO NOT** adjust the safety overload valve.
- X **DO NOT** yank the hose from the air supply, and **DO NOT** direct air from the air hose at yourself or others.
- ✓ Ensure there are no persons or obstructions beneath the vehicle before lowering.
- ✓ When not in use disconnect jack from the air supply, and store in the lowered position in a safe, dry, childproof area.
- ❑ **WARNING!** Turn off air supply and de-pressurise the control nozzle before removing the pump unit from any installation or mobile system.  
*Failure to comply with this instruction may damage the unit and will invalidate your warranty.*

## 2. SPECIFICATIONS

*Note: The maximum heights shown may be extended by use of the extension pins*

Model No	YAJ15-30	YAJ15-30DC	YAJ20-40	YAJ20-40DC	YAJ20-40LR
<b>Maximum Capacity</b>	30Tonne	30Tonne	40Tonne	40Tonne	40Tonne
<b>Minimum Height</b>	175mm	150mm	175mm	150mm	190mm
<b>Maximum Height/Capacity (mm/Tonne)</b>					
<b>Stage 1</b>	472/15	409/15	472/20	409/20	504/20
<b>Stage 2</b>	393/30	343/30	393/40	343/40	416/40
<b>Extension</b>	45/75mm	45/75mm	45/75mm	45/75mm	45/75mm
<b>Chassis Length</b>	480mm	430mm	480mm	430mm	770mm
<b>Length inc. Handle</b>					
<b>Position 1</b>	460mm	1280mm	460mm	1280mm	820mm
<b>Position 2</b>	1380mm	1600mm	1380mm	1600mm	1770mm
<b>Position 3</b>	1700mm	-	1700mm	-	2100mm
<b>Width</b>	290mm	290mm	290mm	290mm	282mm
<b>Working Pressure</b>	116-145psi	116-145psi	116-145psi	116-145psi	116-174psi
<b>Air Flow</b>	10.5cfm	10.5cfm	10.5cfm	10.5cfm	11.5cfm
<b>Weight</b>	39kg	31kg	41kg	33kg	62kg

## 3. INTRODUCTION

- 3.1. Ideal for workshop or roadside use, these jacks take the effort out of lifting heavy plant, tractors and commercial vehicles. Models feature dead man's control for extra safety (detachable on Model No's YAJ15-30DC and YAJ20-40DC making these models extremely portable) and multi-position locking handles. Each jack is supplied with a 45mm and 75mm extension to help close the gap between the saddle of the jack and the jacking point. Model No. YAJ20-40LR also offers a long reach chassis, ideal for accessing deep set jacking points.

## 4. ASSEMBLY

- 4.1. **Attaching the Handle - YAJ15-30, YAJ20-40, YAJ20-40LR**
- 4.1.1. Remove a circlip from either side of the large pin (fig.1A).
- 4.1.2. Slide out the pin and place the handle into the opening. Slide the pin back through the jack, lining up the handle and through the other side. Secure with circlips.
- 4.2. **Air Hoses - YAJ15-30, YAJ20-40, YAJ20-40LR**
- 4.2.1. Screw in the two air hoses from the handle into the jack.
- 4.2.2. The hose marked orange must be screwed into the left-hand side. The hose marked black or clear into the right-hand side. (fig.1).
- 4.2.3. Ensure the hoses are tight and do not obstruct the movement of the handle.

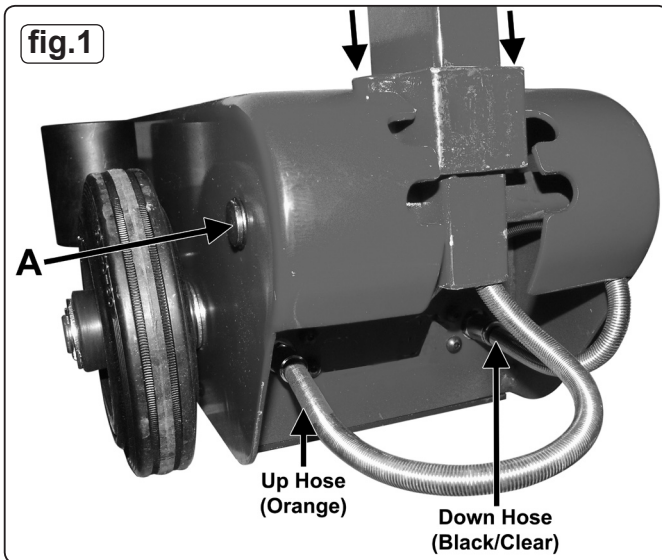

## 5. AIR SUPPLY

- 5.1. Ensure that the jack pneumatic switch is in the "off" position before connecting to the air supply.
- 5.2. You will require an air pressure of at least 116psi (max 145psi or 174psi for YAJ20-40LR) and an air flow of 10.5cfm or 11.5cfm for YAJ20-40LR to get the best performance from this jack.
- 5.3.  **WARNING!** Ensure the air supply does not exceed 145psi or 174psi for YAJ20-40LR while operating the jack. Too high an air pressure and unclean air will shorten the products life due to excessive wear, and may be dangerous causing possible damage and personal injury.
- 5.4. Drain the air tank daily. Water in the air line will damage the jack.
- 5.5. Clean the air inlet filter screen weekly.
- 5.6. Keep the air hose between the compressor and the air jack as short as possible, and install an air filter and oiler (fig.2).
- 5.7. Line pressure should be increased to compensate for unusually long air hoses (over 8 metres). The minimum hose diameter should be 3/8" I.D. and fittings must have the same inside dimensions.
- 5.8. Keep hose away from heat, oil and sharp edges. Check hoses for wear, and make certain that all connections are secure.

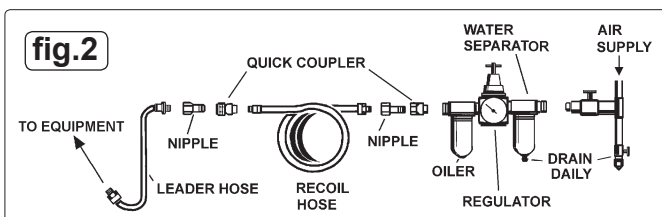

## 6. OPERATION

- 6.1. **Preparation - YAJ15-30, YAJ20-40, YAJ20-40LR**
  - 6.1.1. You will require an air pressure of at least 116psi (max 145psi or 174psi for YAJ20-40LR) and an air flow of 10.5cfm or 11.5cfm for YAJ20-40LR to get the best performance from the jack.
  - 6.1.2. Connect the air supply to the connector (fig.3B).
  - 6.1.3. Set the handle to the required angle using the handle release lever shown in fig.3A. Pull the lever upwards towards the main handle. Move the handle to the required position and release the lever to lock it into position.
- 6.2. **Preparation - YAJ15-30DC, YAJ20-40DC**
  - 6.2.1. Connect the air supply to the connector (fig.4A).
  - 6.2.2. To change the handle position on the "DC" models turn the handle (fig.4D) anti-clockwise then pull out of socket, insert into the other handle socket and turn clockwise to secure.
  - 6.2.3. On the "DC" models the controls (fig.4B) are detachable, lift and slide off the handle before putting the jack under the vehicle.

- 6.3. **Purge the System - YAJ15-30, YAJ20-40, YAJ20-40LR**

Before using the jack, purge the hydraulic circuit in order to eliminate any possible air that may have entered the system during transit.

  - 6.3.1. Push the control lever (fig.5A) to the 'down' position and hold it there for several seconds. Release the lever to the centre 'hold' position.
  - 6.3.2. Now push the lever to the 'up' position and hold it there until the jack is fully extended. Push the lever to the 'down' position and watch the jack as it retracts. The lowering movement should be smooth and without irregular stops.
  - 6.3.3. Repeat the raising and lowering cycle until the movement is smooth. Once this has been achieved this indicates that all air has been expelled.

- 6.4. **Purge the System - YAJ15-30DC, YAJ20-40DC**

Before using the jack, purge the hydraulic circuit in order to eliminate any possible air that may have entered the system during transit.

  - 6.4.1. Push the down button (fig.6B) and hold it there for several seconds. Release the button.
  - 6.4.2. Now push the 'up' button and hold it there until the jack is fully extended. Push the 'down' button and watch the jack as it retracts. The lowering movement should be smooth and without irregular stops.
  - 6.4.3. Repeat the raising and lowering cycle until the movement is smooth. Once this has been achieved this indicates that all air has been expelled.

- 6.5. **Using the Jack - YAJ15-30, YAJ20-40, YAJ20-40LR**

**WARNING!** ensure you have read and understood the safety instructions in chapter 1 before commencing work.

  - 6.5.1. Position the Jack under the vehicle manufacturer's recommended jacking point (see vehicle hand book).

*Note: Use the extension pins (fig.3D) to get the jack closer to the jacking point before engaging the jack. See specification for capacity when using the extension pins.*
  - 6.5.2. Whilst holding the main jack handle lifting is achieved by pushing the control lever to the 'up' position (fig.5B).
  - 6.5.3. When the vehicle has reached the desired height release the control lever which will automatically return to the middle hold position stopping any further air flow holding the jack at the height to which it has been raised.
  - 6.5.4. Place axle stands correctly in position and ensure chapter 1 safety instructions are strictly applied before performing any task.

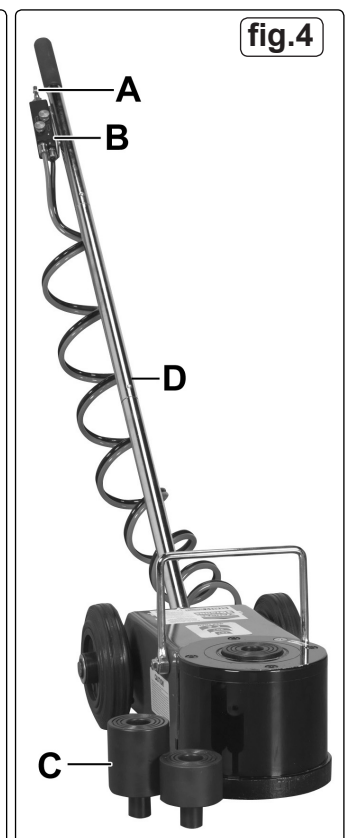
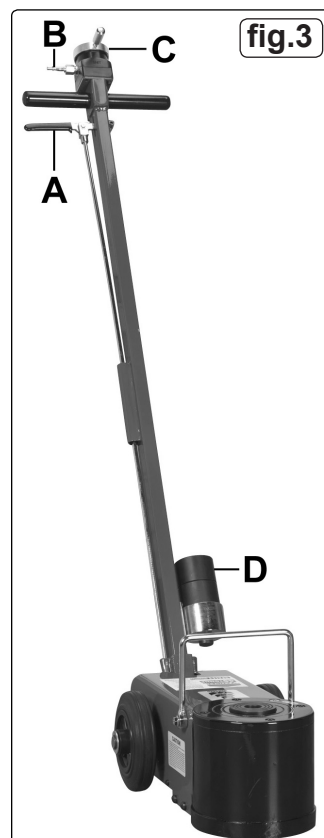
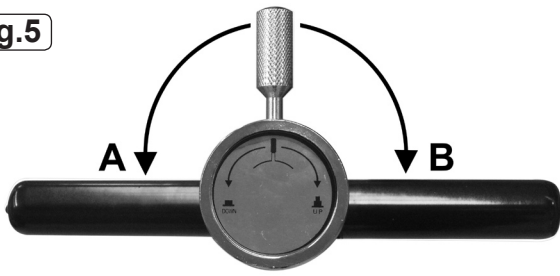

fig.5



**6.6. Using the Jack - YAJ15-30DC, YAJ20-40DC**

❑ **WARNING!** ensure you have read and understood the safety instructions in chapter 1 before commencing work.

6.6.1. Position the Jack under the vehicle manufacturer's recommended jacking point (see vehicle hand book).

Note: Use the extension pins (fig.3D/fig.4C) to get the jack closer to the jacking point before engaging the jack. See specification for capacity when using the extension pins.

6.6.2. Whilst holding the main jack handle lifting is achieved by pushing the 'up' button (fig.6A).

6.6.3. When the vehicle has reached the desired height release the 'up' button, stopping any further air flow holding the jack at the height to which it has been raised.

6.6.4. Place axle stands correctly in position and ensure chapter 1 safety instructions are strictly applied before performing any task.

**6.7. Lowering the Jack**

6.7.1. Ensure there are no persons or obstruction beneath the vehicle before lowering, and remove any axle stands.

6.7.2. Whilst holding the main jack handle lowering is achieved by pushing the control lever/button down (fig.5A/fig.6B), and the jack will lower in a controlled manner.

6.7.3. Once completely lowered releasing the control lever will return it to the middle hold position. Remove the jack from under the vehicle. If you have finished using the jack, turn the air pressure supply off and disconnect the jack from the air line and store the jack and air line accordingly.

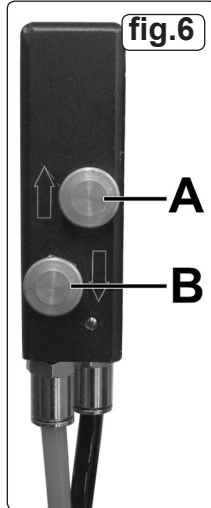

fig.6

❑ **WARNING! DO NOT** use brake fluid, or any fluid other than hydraulic jack fluid as this may cause serious damage to the Jack and will invalidate the warranty!

7.4. Ensure the air filter located in the air valve is clean.

7.5. Should the piston not rise and the oil level is correct, this may indicate a problem with air seeping into the hydraulic valve passage. Purge any air from the system. See 6.3 / 6.4.

7.6. Confirm that the piston can rise to the highest position.

7.7. Before each use check for broken, cracked, bent, or loose parts. Or any visible damage to welds, piston, pump, saddle, air connector, levers, frame and all parts including nuts, bolts, pins and other fasteners. If any suspect item is found, remove jack from service and take necessary action to fix the problem. **DO NOT** use the jack if believed to have been subjected to abnormal load or shock. Inspect and take appropriate action.

7.8. Every three months remove the locking rings on the caster wheels and lubricate the ball bearings with grease.

7.9. After a year of extensive use, the oil should be replaced in order to extend the life of the jack. To drain the oil, remove the filler plug and valve. Make sure that no dirt is allowed to enter the hydraulic system See 7.3. for refilling instructions.

7.10. Periodically check the pump piston and piston rod for signs of corrosion. Clean exposed areas with a clean oiled cloth.

**IMPORTANT: NO RESPONSIBILITY IS ACCEPTED FOR INCORRECT USE OF THE MACHINE.**

Air / Hydraulic products are only repaired by local service agents. We have service/repair agents in all parts of the UK. **DO NOT RETURN JACKS TO US.** Please telephone us on 01284 757500 to obtain the address and phone number of your local agent. If jack is under guarantee please contact your dealer.

**De-commissioning the Jack**

Should the jack become completely unserviceable and require disposal, draw off the oil into an approved container and dispose of the jack and the oil according to local regulations.

**8. TROUBLESHOOTING**

PROBLEM	POSSIBLE CAUSE	REMEDY
Jack does not lift but pump is ok.	1. Oil Exhausted. 2. Air in hydraulic system.  3. Defective suction or delivery valves. 4. Defective packing or O-ring. 5. Poor quality oil.	1. Supply oil. 2. Drain air by opening cap plug of suction and delivery valves. 3. Clean clogged valve. 4. Replace. 5. Replace oil.
Air pump does not operate.	1. Insufficient compressor power. 2. Pump oil used up.	1. Use a larger compressor. 2. Find leak and rectify, refill with oil. Rebuild and lubricate air valve.
Jack stops before end of travel.	1. Hydraulic oil is insufficient.	1. Supply oil.
Jack Lowers or does not hold in the raised position.	1. Defective suction delivery, release or safety valve. 2. Defective piston packing.	1. Clean and adjust valve. 2. Replace packing.
Lifting is slow.	1. Air leakage due to worn servo-valve.	1. Replace servo-valve.
Pump continues to operate when the air valves are closed	1. Air valve will not close.	1. Replace Valve.

**7. MAINTENANCE**

**IMPORTANT: Only fully qualified personnel should attempt maintenance or repair.**

❑ **WARNING!** Disconnect jack from air supply before changing parts, servicing or performing any maintenance.

7.1. When the jack is not in use, the piston must be in the lowest position to minimise corrosion.

7.2. Keep the jack clean and lubricate all moving parts, and the air intake connector with air tool oil on a regular basis.

7.3. To check oil level, fully lower jack. Remove the filler plug (located next to the piston or for YAJ20-40LR it is located on the side of the jack). The oil level should be level with the indicator inside the filler hole, for YAJ20-40LR, it should be level with the bottom of the filler hole.

Top up the oil level if necessary but do not overfill as the jack will become inoperative. If inadvertently overfilled the excess oil should be poured off. After topping up or pouring off excess oil it may become necessary to purge air from the unit. See section 6.3 / 6.4.

**NOTE:** Use a good quality Jack oil, such a SEALEY HYDRAULIC JACK OIL.

Parts support is available for this product. To obtain a parts listing and/or diagram, please log on to [www.sealey.co.uk](http://www.sealey.co.uk), email [sales@sealey.co.uk](mailto:sales@sealey.co.uk) or phone 01284 757500.

**NOTE:** It is our policy to continually improve products and as such we reserve the right to alter data, specifications and component parts without prior notice.

**IMPORTANT:** No liability is accepted for incorrect use of this product.

**WARRANTY:** Guarantee is 12 months from purchase date, proof of which will be required for any claim.

**INFORMATION:** For a copy of our latest catalogue and promotions call us on 01284 757525 and leave your full name and address, including postcode.



Sole UK Distributor, Sealey Group,  
Kempson Way, Suffolk Business Park,  
Bury St. Edmunds, Suffolk,  
IP32 7AR

☎ 01284 757500

🌐 [www.sealey.co.uk](http://www.sealey.co.uk)

✉ 01284 703534

✉ [sales@sealey.co.uk](mailto:sales@sealey.co.uk)