

Thank you for purchasing a Sealey product. Manufactured to a high standard this product will, if used according to these instructions and properly maintained, give you years of trouble free performance.

⚠ IMPORTANT: PLEASE READ THESE INSTRUCTIONS CAREFULLY. NOTE THE SAFE OPERATIONAL REQUIREMENTS, WARNINGS & CAUTIONS. USE THE PRODUCT CORRECTLY AND WITH CARE FOR THE PURPOSE FOR WHICH IT IS INTENDED. FAILURE TO DO SO MAY CAUSE DAMAGE OR PERSONAL INJURY, AND WILL INVALIDATE THE WARRANTY. PLEASE KEEP INSTRUCTIONS SAFE FOR FUTURE USE.

1. SAFETY INSTRUCTIONS

1.1. ELECTRICAL SAFETY

⚠ WARNING! It is the responsibility of the owner and the operator to read, understand and comply with the following: You must check all electrical products, before use, to ensure that they are safe. You must inspect power cables, plugs, sockets and any other connectors for wear or damage. You must ensure that the risk of electric shock is minimised by the installation of appropriate safety devices. A Residual Current Breaker (RCCB) should be incorporated in the main distribution board. We also recommend that a Residual Current Device (RCD) is used. It is particularly important to use an RCD with portable products that are plugged into a supply which is not protected by an RCCB. If in any doubt consult a qualified electrician. You may obtain a Residual Current Device by contacting your Sealey dealer. **You must** also read and understand the following instructions concerning electrical safety.

- 1.1.1. The **Electricity at Work Act 1989** requires that all portable electrical appliances, if used on business premises, are tested by a qualified electrician, using a Portable Appliance Tester (PAT), at least once a year.
- 1.1.2. The **Health & Safety at Work Act 1974** makes owners of electrical appliances responsible for the safe condition of those appliances and the safety of the appliance operators. **If in any doubt about electrical safety, contact a qualified electrician.**
- 1.1.3. Ensure that the insulation on all cables and on the appliance is safe before connecting it to the power supply. See 1.1.1. and 1.1.2. and use a Portable Appliance Tester.
- 1.1.4. Ensure that cables are always protected against short circuit and overload.
- 1.1.5. Regularly inspect power supply cables and plugs for wear or damage and check all connections to ensure that none is loose.
- 1.1.6. **Important:** Ensure that the voltage marked on the appliance matches the power supply to be used and that the plug is fitted with the correct fuse - see fuse rating at right.
- 1.1.7. **DO NOT** pull or carry the appliance by the power cable.
- 1.1.8. **DO NOT** pull the plug from the socket by the cable.
- 1.1.9. **DO NOT** use worn or damaged cables, plugs or connectors. Immediately have any faulty item repaired or replaced by a qualified electrician. When a BS 1363/A UK 3 pin plug is damaged, cut the cable just above the plug and **dispose of the plug safely.** Fit a new plug according to the following instructions (UK only).

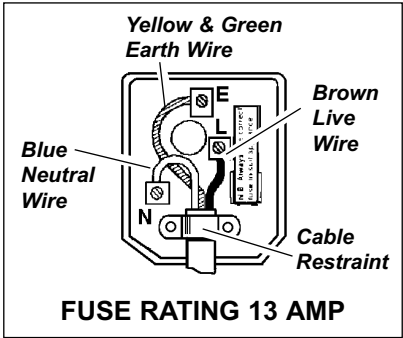

- a) Connect the **GREEN/YELLOW** earth wire to the earth terminal 'E'.
 - b) Connect the **BROWN** live wire to the live terminal 'L'.
 - c) Connect the **BLUE** neutral wire to the neutral terminal 'N'.
 - d) **After wiring, check that there are no bare wires, that all wires have been correctly connected, that the cable outer insulation extends beyond the cable restraint and that the restraint is tight.**
- Double insulated products, which are always marked with this symbol , are fitted with live (brown) and neutral (blue) wires only. To rewire, connect the wires as indicated above - **DO NOT** connect either wire to the earth terminal.

- 1.1.10. Products which require more than 13 amps are supplied without a plug. In this case you must contact a qualified electrician to ensure that a suitably rated supply is available. We recommend that you discuss the installation of an industrial round pin plug and socket with your electrician.
- 1.1.11. If an extension reel is used it should be fully unwound before connection. A reel with an RCD fitted is preferred since any appliance plugged into it will be protected. The cable core section is important and should be at least 1.5mm², but to be absolutely sure that the capacity of the reel is suitable for this product and for others which may be used in the other output sockets, we recommend the use of 2.5mm² section cable.

1.2 GENERAL SAFETY

- ⚠ WARNING!** Disconnect the dehumidifier from the mains power before servicing or performing any maintenance.
- ✓ Maintain the dehumidifier in good condition (use an authorised service agent).
- ✓ Replace or repair damaged parts. *Use genuine parts only. Non-authorized parts may be dangerous and will invalidate the warranty.*
- ✓ Use dehumidifier only on level and solid floors.
- x **DO NOT** use the dehumidifier for any purpose other than that for which it is designed.
- x **DO NOT** operate the dehumidifier if any parts are damaged or missing as this may cause failure and/or personal injury.
- x **DO NOT** allow untrained persons to operate the dehumidifier.
- x **DO NOT** use the dehumidifier where there are flammable liquids, solids or gases such as paint solvents, etc.
- x **DO NOT** pull the cord from the power supply.
- ✓ When not in use switch off the dehumidifier, remove plug from the power supply.



2. INTRODUCTION & SPECIFICATIONS

The XRC commercial/industrial dehumidifier range is designed to remove moisture from the air in high humidity environments such as cellars, kitchens, bathrooms etc. The units are designed for continuous operation either manually or automatically if connected to an optional hygrostat sensor. The internal cooling units use the more environmentally friendly R407C cooling gas. All units have an air filtering system, electronic control, a defrost system for compressor protection, and an automatic stop when the water collection tank is full. The units are easy to move and robustly constructed.

MODEL NO . .Units of measurement/spec. .XRC25XRC40XRC55XRC90

Electrical power	.W	650	800	831	1205
Max. current	.A	.3	.4	.5	.7
Drying capacity	.30°C / 80%RH (L / 24H)	.23	.42	.53	.88
	.27°C / 60%RH (L / 24H)	.11	.27	.37	.54
	.12°C / 70%RH (L / 24H)	.5	.7	.18	.22
Working range (Humidity)	%. .	40 -100	40 -100	40 -100	40 -100
Working range (Temperature)	°C. .	5 - 30	5 - 30	5 - 30	5 - 30
Air flow	.m³/h	.350	.500	.600	.800
Cooling gas type	.Gas	.R407C	.R407C	.R407C	.R407C
Cooling gas mass	.(g)	.350	.500	.525	.700
Compressor		.Reciprocating	.Rotary	.Rotary	.Rotary
Container full LED		.Yes	.Yes	.Yes	.Yes
Compressor protection		.Yes	.Yes	.Yes	.Yes
Filter		.Yes	.Yes	.Yes	.Yes
Tank capacity	.Litres	.10	.10	.10	.10
Weight	.Kg	.34	.51	.57	.63
Dimensions	.mm	.455x370x635	.540x460x860	.970x670x650	.985x700x700

fig.1

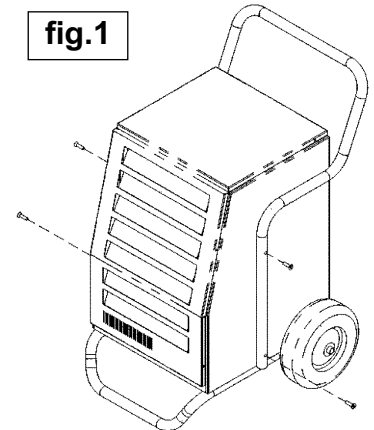

3. TRANSPORT & ASSEMBLY

- 3.1 **Transit.** The unit should be transported in a vertical position or inclined on the handle side. If it has been transported in a horizontal position allow the unit to stand in the vertical position for about one hour to allow the lubrication to be rebalanced.
- 3.2 Check that the unit has not been damaged in any way and that all parts are present. If there are any problems contact your local Sealey dealer.
- 3.3 **Packaging.** Packaging materials such as cartons, polythene bags etc should not be left within the reach of children as such items could be dangerous to them. Dispose of all packaging materials in accordance with local authority requirements.
- 3.4 **Assembly.** Assemble the main handle to the body of the unit as shown in fig.1 using the fixing screws provided.

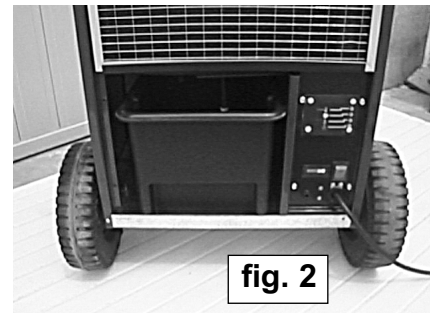

fig. 2

4. INSTALLATION

- 4.1 **It is important that the air inlet and air outlet remain unobstructed at all times.**
- 4.2 The following minimum safety distances are recommended between the unit and walls or objects.
 - **Minimum distance from air inlet - 0.6m.**
 - **Minimum distance from air outlet - 3.0m.**
- 4.3 Ideally the unit should be installed in the centre of the room to guarantee the best possible air circulation.
- 4.4 **DO NOT** install the unit near heat sources. Keep windows and doors closed whilst the unit is operating.
- 4.5 **Dual voltage models (XRC55 & 90).** The dual voltage models are designed to run off either a 230V 50Hz supply or a 110V 50Hz supply. To select the required voltage do the following:

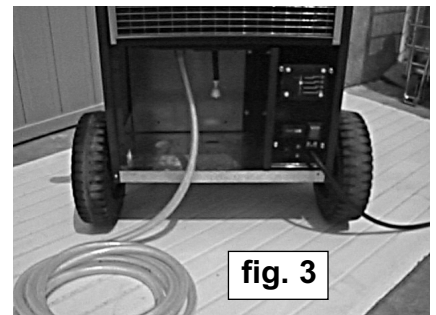

fig. 3

- Remove the two fixing screws holding the voltage selector cover plate.
 - Move the selector switch to the required voltage. • Reverse the cover plate and screw it back into position.
- 4.6 **Water drain.** Drained water can be collected and eliminated in 2 ways:
 - A) Using the tank supplied as shown in fig.2. The tank must be emptied when the yellow 'tank full' LED lights up. Switch the unit off before emptying the tank and disconnect the mains plug. Remove the tank carefully to avoid spills and empty it. Slide the tank back into the unit ensuring that the level sensor is correctly placed within the tank.
NOTE: When the dehumidifier is switched off and then restarted, the compressor will not start to run immediately but will cut in again after some minutes. This waiting time protects the compressor from repeated starts at short intervals.
 - B) Water may be removed by connecting a plastic hose with an internal diameter of 14mm to the hose holder in the drain compartment. (Plastic hose not supplied.) See fig.3.
Special attention should be paid not to raise the outlet of the hose over the drain level of the unit. (Max height 1ft, see fig.4) Failure to do this will result in water spillage and flooding of the unit.
 - 4.7 **Connection of a Hygrostat.** A hygrostat control is also available as an optional accessory. This enables the unit to function automatically. The remote hygrostat will be located near the air inlet and is connected to the unit via a jack plug on the units control panel

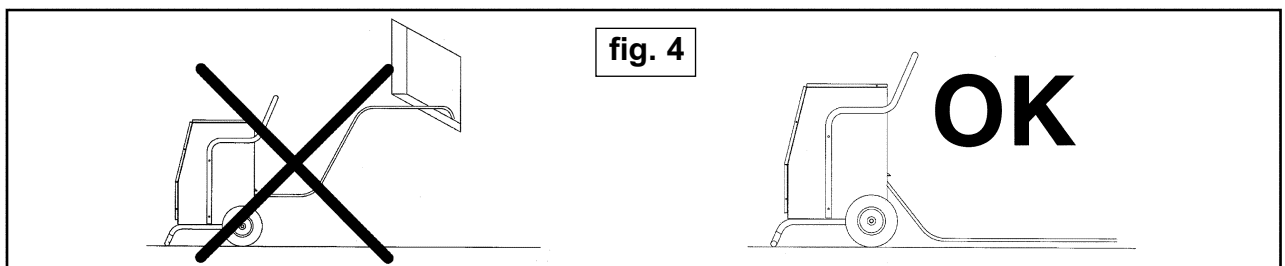
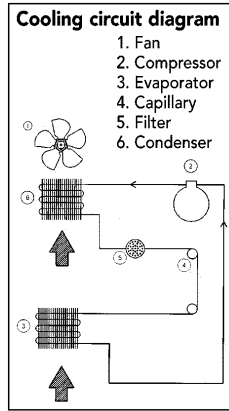
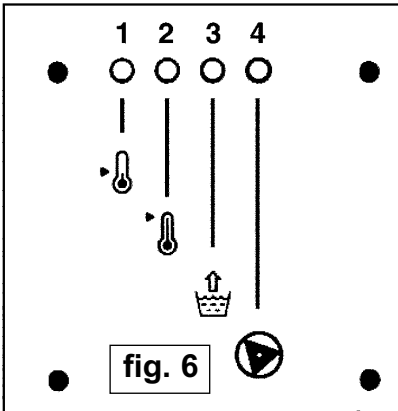

fig. 4

5. OPERATION

- 5.1 **Dual Voltage Models XRC55 & XRC90.** Before operating the unit ensure that the correct voltage has been selected.
- 5.2 **Continuous operation in manual mode.**
- 5.2.1 Connect the unit to the mains power supply.
- 5.2.2 Switch the unit on by moving the on/off switch to the 'I' position at which point the switch should illuminate. After a few minutes the green LED on the control panel will illuminate indicating that the compressor has started. In this mode the unit will dry the air continuously until the unit is switched off again.
- 5.2.3 To switch the unit off move the on/off switch to the 'O' position.
- 5.3 **Automatic operation using a remote hygrosstat. (Optional)**
- 5.3.1 Connect the unit to the mains power supply.
- 5.3.2 Connect the hygrosstat lead to the jack socket on the units control panel. Switch the unit on. After a few minutes the green LED will illuminate and the compressor will start to rotate. Set the desired level of humidity on the hygrosstat. If the general humidity is higher than the preset value the unit will start to operate. When the humidity has reached the preset value the compressor will be switched off automatically but the fan will continue to operate. When the air humidity increases above the preset value the compressor will cut in again. This automatic cycling will continue until the unit is switched off.
- 5.4 **Electronic control.**
- 5.4.1 Each dehumidifier is equipped with an electronic control unit with related LED display panel which can be seen on the rear of the dehumidifier. The functions of the LEDs are as follows, (see fig.6).
- 5.4.2 **ORANGE LED.** The room temperature is too low or the unit is in defrost mode.
- 5.4.3 **RED LED.** The room temperature is too high or a reduction of air flow has occurred. Check filter and remove obstructions to air flow if required. Check that the fan is rotating.
- 5.4.4 **YELLOW LED.** The water tank is full. Empty tank or check pump.
- 5.4.5 **GREEN LED.** The compressor is running.



6. MAINTAINANCE

- 6.1 Unplug the unit from the power supply before carrying out any maintenance or service.
- 6.2 **Cleaning the filter.** To maintain the efficiency of the unit wash the filter in luke warm water on a regular basis.
- 6.3 **Cleaning the unit.** Clean the unit at least once a year. Remove air filter, remove front and rear panels to gain access to inner parts. Clean inner parts using compressed air paying particular attention to the condenser, evaporator and water drainage tray.

Declaration of Conformity We, the sole importer into the UK, declare that the products listed below are in conformity with the following standards and directives.

Dehumidifiers
Models XRC25, 40, 50 & 90
 73/232/EEC Low Voltage Directive
 89/336/EEC EMC Directive



The construction files for these products are held by the Manufacturer and may be inspected, by a national authority, upon request to Jack Sealey Ltd.

Signed by Mark Sweetman

14th April 2003

For Jack Sealey Ltd. Sole importer into the UK of Sealey Power Tools.

NOTE: It is our policy to continually improve products and as such we reserve the right to alter data, specifications and component parts without prior notice.
IMPORTANT: No liability is accepted for incorrect use of this product. **WARRANTY:** Guarantee is 12 months from purchase date, proof of which will be required for any claim. **INFORMATION:** Call us for a copy of our latest catalogue on 01284 757525 and leave your full name and address including your postcode.

SEALEY POWER PRODUCTS Sole UK Distributor
 Sealey Group,
 Bury St. Edmunds, Suffolk.

01284 757500
 01284 703534

www.sealey.co.uk
sales@sealey.co.uk

Wiring diagram 230V models

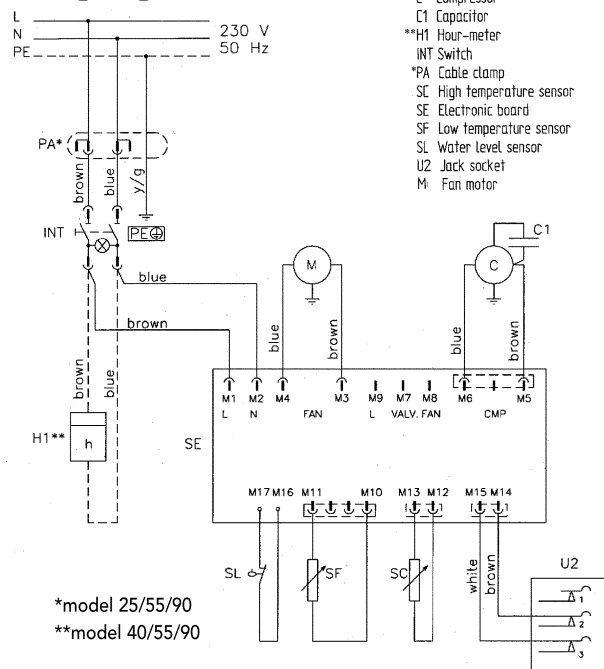

Wiring diagram DV models

