

Your new Wheel Skate is produced and manufactured to a high standard of dependability and will, if used according to these instructions and properly maintained, give you years of trouble free performance.



**IMPORTANT: READ THESE INSTRUCTIONS CAREFULLY. NOTE THE SAFE OPERATIONAL REQUIREMENTS, WARNINGS AND CAUTIONS. USE THESE SKATES CORRECTLY AND WITH CARE FOR THE PURPOSE FOR WHICH THEY ARE INTENDED. FAILURE TO DO SO MAY CAUSE DAMAGE AND/OR PERSONAL INJURY AND WILL INVALIDATE THE WARRANTY. RETAIN THESE INSTRUCTIONS FOR FUTURE USE.**

### 1. SAFETY PRECAUTIONS

- ❑ **WARNING!** Ensure Health & Safety, local authority, and general workshop practice regulations are adhered to when using this equipment.
- ✓ Familiarise yourself with this product's application and limitations, as well as the specific warnings below relating to their use.
- ✓ Ensure the Wheel Skates are in sound condition and good working order. Take action for immediate repair or replacement of damaged parts.  
*Use genuine parts only. The use of improper parts may be dangerous and will invalidate the warranty.*
- ✓ Wheel Skates should only be used in suitable, well lit areas.
- ✓ **Wheel Skates must be used in pairs at either the front or rear of the vehicle.**  
They must never be used diagonally.
- ✓ Keep general area clean and tidy and free from obstructions.
- ✓ Use Wheel Skates on level and solid ground, preferably concrete. *Avoid tarmac/adam as Wheel Skates may sink in.*
- ✓ Maintain the Wheel Skates in good condition (use an authorised service agent).
- ✓ Ensure there are no passengers in the vehicle.
- ✓ Ensure the Wheel Skates are free to move and that there are no obstructions in the area of use.
- ✓ When not in use store Wheel Skates in a safe, dry, childproof area.
- ❑ **DANGER:** Use the Wheel Skates for manoeuvring or positioning of vehicles in interior situations. They are not designed for use outdoors.  
**DO NOT start or drive the vehicle whilst it is raised on wheel skates.**
- x **DO NOT** use the Wheel Skates for purposes other than that for which they are intended.
- x **DO NOT** allow untrained persons to operate the Wheel Skates.
- x **DO NOT** leave the vehicle unattended whilst it is raised on the Wheel Skates.
- x **DO NOT** operate the Wheel Skates when you are tired or under the influence of alcohol, drugs or intoxicating medication.
- x **DO NOT** get the Wheel Skates wet or use in damp or wet locations or areas where there is condensation.
- x **DO NOT** exceed the rated capacity of the Wheel Skates. Remember that the front of a vehicle is usually heavier than the rear.
- x **DO NOT** use the Wheel Skates to lift or support a vehicle in order to do work underneath it.
- ✓ Maintain correct balance and footing when moving vehicle. Ensure the floor is not slippery and wear non-slip shoes.
- ✓ Ensure there are no obstructions beneath the vehicle when it is to be lowered.
- ✓ Ensure all non-essential persons keep a safe distance whilst the Wheel Skates are in use.
- IMPORTANT** - We recommend that at least 2 persons are involved in manoeuvring the vehicle when supported on wheel skates. The vehicle's weight provides a large amount of inertia which has to be overcome to get the vehicle moving and more importantly, stopped.
- ❑ **WARNING!** The warnings, cautions and instructions covered in this manual cannot cover all possible conditions and situations that may occur. It must be understood that common sense and caution are factors which cannot be built into this product, but must be applied by the operator.



### 2. INTRODUCTION & SPECIFICATION

Steel chassis with PVC rollers and four Ø100mm PU castors, two fitted with brakes. Pedal operated hydraulic lifting action with safety locking pin when under load. Rollers cradle vehicle's tyre and are capable of handling up to 300mm profile. Suitable for bodyshops, garages, showrooms or anywhere a disabled vehicle needs moving on an even surface.

**Note:** Skates sold as singles, but must be used in pairs.

Lifting capacity per Skate: . . . 650kg  
Wheel Ø: . . . . . Ø100mm

Maximum Opening: . . . . 625mm  
Weight (Each): . . . . . 17kg

Maximum Tyre Profile: . . . . . 300mm

### 3. OPERATING INSTRUCTIONS

- 3.1. **Preparation.**
- 3.1.1. Ensure that the area where the vehicle is to be moved is clear of any obstructions. The floor surface should be smooth and level. Take note of any features in the floor that may catch the skate wheels such as floor mounted power and data points, room divider tracks, drainage features, or damage to the floor surface.
- 3.1.2. Enlist sufficient manpower to move the vehicle safely. Do not attempt to move the vehicle into an area where there is insufficient space to manoeuvre the vehicle safely.
- 3.1.3. Prior to operation, release the foot pedal from the transit hook by depressing the pedal slightly and moving the hook to one side to allow the pedal to rise up (fig.1).
- 3.1.4. **Wheel Skates must be used as a pair.** Attach to the front wheels to swing the front of the vehicle. (Do not release the **hand-brake** or remove **wheel chocks** until both Skates are attached. Re-engage the **hand-brake** or **chock** the wheels immediately the movement has been made.) Attach to the back wheels to swing the back of the vehicle. (Ideally the front wheels should be straight.) If you intend to use two pairs of skates to move a vehicle in one movement great care should be exercised in order to avoid injury to persons or property.

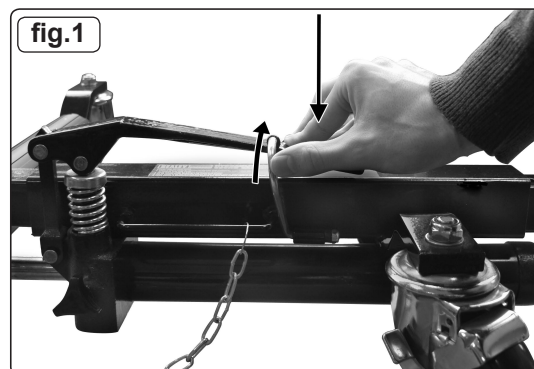

❑ **IMPORTANT: BEFORE THE FIRST USE OF SKATE PURGE AIR FROM THE HYDRAULIC CIRCUIT.**

- 3.1.5 Purging the hydraulic circuit eliminates any air that may have accumulated in the system during transit, purge as below:
- Open the release valve by turning release valve (fig.2) anti-clockwise.
  - Pump the pedal up and down 15 to 20 times.
  - Turn the release valve clockwise to close the valve.

Refer to section 1 before using wheel skate.

**3.2 Operation.**

- 3.2.1. To fit a Skate to a wheel you must first turn the release valve anti-clockwise (fig.2) and remove the locking pin (fig.3).

**3.3. Positioning the Skate.**

- 3.3.1. Take hold of each side of the frame and expand the unit until it is wide enough to slide the rollers either side of the tyre. Make sure that both sets of rollers are centred on the tyre. Lock the castor brakes.

**3.4. Raising a wheel.**

- 3.4.1. Now close the release valve by turning clockwise (fig.2).
- 3.4.2. Operate the foot pedal lever to commence raising the wheel. (**IMPORTANT - Allow the pedal to return through its full travel before commencing the next stroke.**) Continue until the tyre is clear of the ground and you are able to insert the locking pin as shown in fig.3.
- 3.4.3. Raise the second wheel off the ground with the other Skate. Be prepared for any movement the vehicle may make when the second wheel comes clear of the ground. This is particularly important when using four skates. Providing the ground/floor is level and the castor brakes on 'ON' the vehicle should remain stable. (Read safety precautions in Section 1.)

**3.5. Moving the Vehicle.**

- 3.5.1. Ensure that the castor brakes are 'OFF' and you have sufficient manpower to move **and control** the vehicle. Keep well away from any sloping areas or entry ramps to the area, however shallow they may appear. When positioning a vehicle in relation to a wall or feature such as a pillar no persons or objects should be situated between the vehicle and the feature. Sufficient space should be left between the side of a vehicle and an adjacent wall or feature to allow the Skates to be withdrawn sideways.

**3.6. Lowering wheels.**

- 3.6.1. Engage the castor brakes, remove the locking pin and turn the release valve anti-clockwise to lower the vehicle until the tyre is on the ground and no longer exerting pressure on the rollers.

**3.7. Removing the Skate.**

- 3.7.1. Expand the unit sufficiently to clear the tyre and move it away from the wheel.

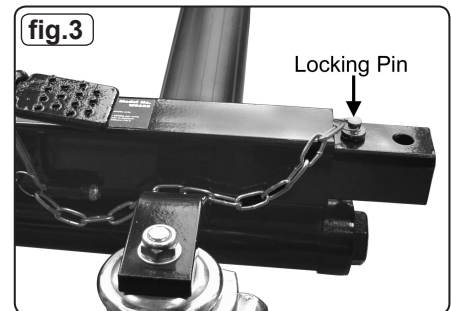
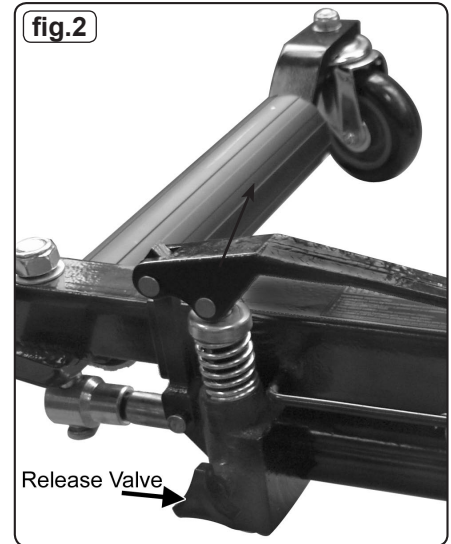

## 4. MAINTENANCE

- 4.1. Periodically lubricate the wheels, rollers and the foot pedal lever pivot with acid free oil. Lightly grease the four faces of the square section tube.
- 4.2. When the skate is not in use, store fully closed with the locking pin in place, this will minimise ram and piston corrosion.
- 4.3. Before each use, ensure components are in good working order. If any suspect item is found remove skate from service and take necessary action to remedy the problem.  
**DO NOT** use the skate if you believe it has been subjected to an abnormal load or shock load. If in doubt contact your local service agent.

**IMPORTANT:** All other maintenance and repair (including oil change) must only be undertaken by fully qualified personnel. Contact your local authorised service agent.

- 4.4. The oil cylinder is a sealed unit and in principle should not be accessed. To top up the oil remove oil plug on the ram. The oil level should be just below the oil plug hole.

❑ **WARNING!** Only a good quality hydraulic Jack oil, such as SEALEY HYDRAULIC JACK OIL must be used, **DO NOT** use brake fluid. **DO NOT** overfill as this will render the skate inoperative.

**IMPORTANT:** NO RESPONSIBILITY IS ACCEPTED FOR INCORRECT USE OF THE SKATE. Hydraulic products are only repaired by local service agents. We have service/repair agents in all parts of the UK. **DO NOT RETURN SKATES TO US.** Please telephone 01284 757500 to obtain address and phone number of your local agent. If your skate is under guarantee please contact your dealer.

**De-commissioning the skate:** If the skate becomes completely unserviceable and requires disposal, draw off the oil into an approved container and dispose of the skate and the oil according to local regulations.

**NOTE:** It is our policy to continually improve products and as such we reserve the right to alter data, specifications and component parts without prior notice.

**IMPORTANT:** No liability is accepted for incorrect use of product.

**WARRANTY:** Guarantee is 12 months from purchase date, proof of which will be required for any claim.

**INFORMATION:** For a copy of our latest catalogue and promotions call us on 01284 757525 and leave your full name and address, including postcode.



Sole UK Distributor  
Sealey Group,  
Bury St. Edmunds, Suffolk.

☎ 01284 757500  
✉ 01284 703534



www.sealey.co.uk  
sales@sealey.co.uk