



LED MAGNIFIER SPECTACLES WITH HEADBAND

MODEL NO: **WL101D**

Thank you for purchasing a Sealey product. Manufactured to a high standard, this product will, if used according to these instructions, and properly maintained, give you years of trouble free performance.



IMPORTANT: PLEASE READ THESE INSTRUCTIONS CAREFULLY. NOTE THE SAFE OPERATIONAL REQUIREMENTS, WARNINGS & CAUTIONS. USE THE PRODUCT CORRECTLY AND WITH CARE FOR THE PURPOSE FOR WHICH IT IS INTENDED. FAILURE TO DO SO MAY CAUSE DAMAGE AND/OR PERSONAL INJURY AND WILL INVALIDATE THE WARRANTY. KEEP THESE INSTRUCTIONS SAFE FOR FUTURE USE.

1. SAFETY

- × **DO NOT** store in direct sunlight.
- × **DO NOT** view the sun or bright lights with the magnifier.

2. INTRODUCTION

Supplied with five interchangeable magnifying lenses from 1.0x - 3.5x magnification. Comfortable frame with padded nose pads and padded forehead. LED light has tilt adjustment to best direct the light. Lens can be moved forward and back to best suit the user. Magnifier Spectacles can be worn with spectacle arms or adjustable headband for maximum comfort. Powered by 3 x AAA batteries (Not supplied).

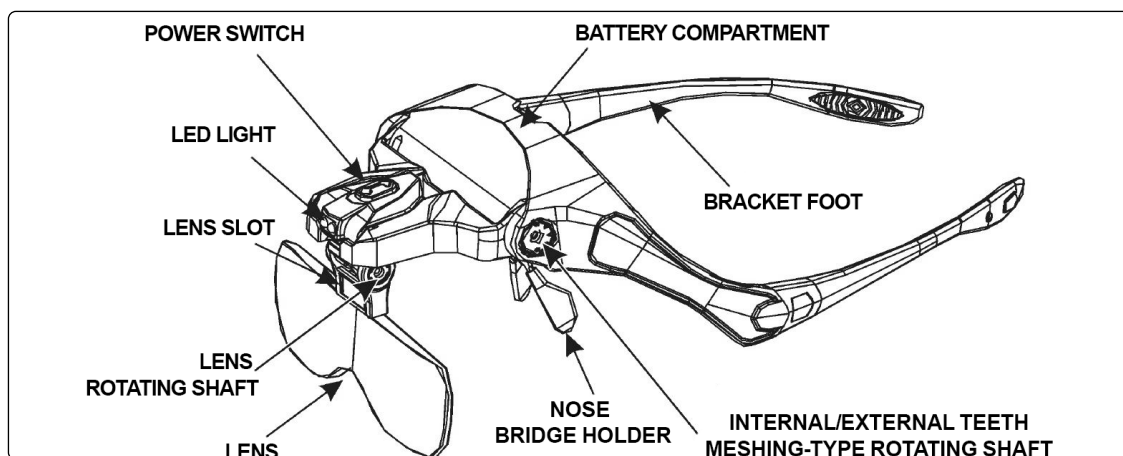

3. OPERATION

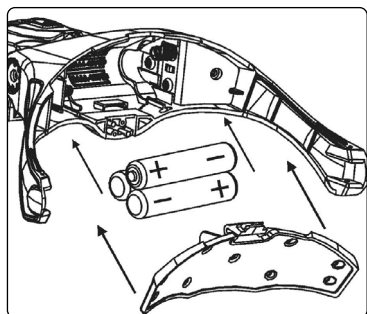

Open the battery cover and insert 3x AAA batteries (not supplied).

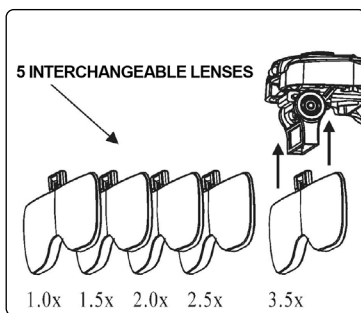

Insert one of the magnifying lenses to suit the user and task.

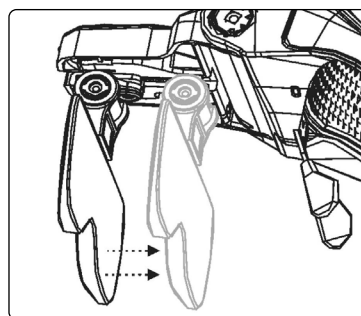

Adjust the position of the lens to suit the user and task.

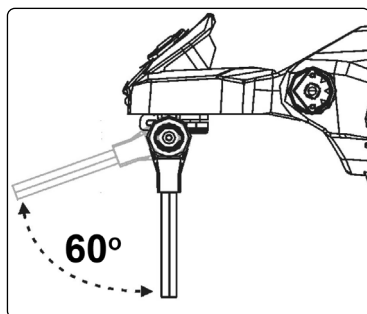

Adjust the angle of the lens.

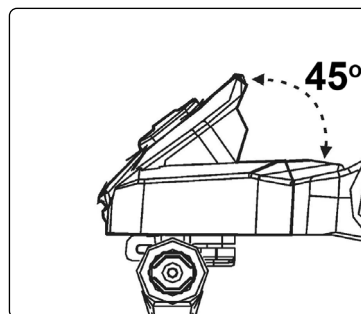

Adjust the angle of the LED light.

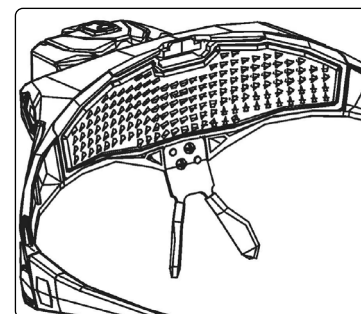

Adjust the bridge to suit the user.

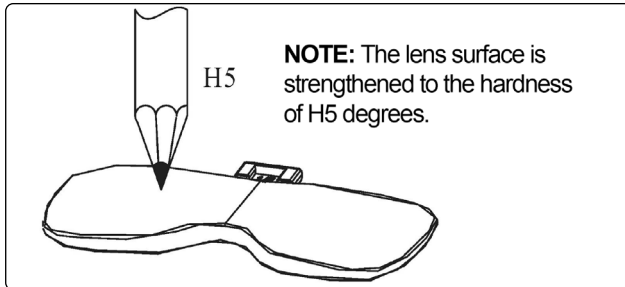
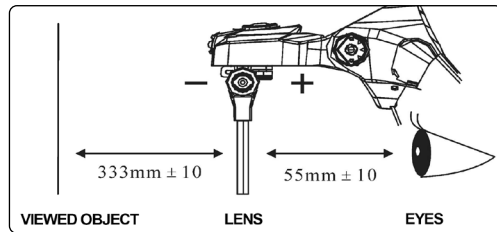
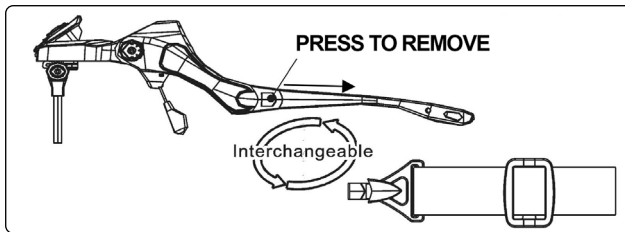

The minimum distance between the eyes and lens is 45mm, and the maximum is 65mm.

4. MAINTENANCE

- ✓ Clean with a soft damp cloth.
- ✗ **DO NOT** use harsh chemicals or alcohol to clean the product.



ENVIRONMENT PROTECTION

Recycle unwanted materials instead of disposing of them as waste. All tools, accessories and packaging should be sorted, taken to a recycling centre and disposed of in a manner which is compatible with the environment. When the product becomes completely unserviceable and requires disposal, drain any fluids (if applicable) into approved containers and dispose of the product and fluids according to local regulations.



Note: It is our policy to continually improve products and as such we reserve the right to alter data, specifications and component parts without prior notice.

Important: No Liability is accepted for incorrect use of this product.

Warranty: Guarantee is 12 months from purchase date, proof of which is required for any claim.

Sealey Group, Kempson Way, Suffolk Business Park, Bury St Edmunds, Suffolk. IP32 7AR



01284 757500



sales@sealey.co.uk



www.sealey.co.uk