

Thank you for purchasing a Sealey product. Manufactured to a high standard this product will, if used according to these instructions and properly maintained, give you years of trouble free performance.

**⚠ IMPORTANT: PLEASE READ THESE INSTRUCTIONS CAREFULLY. NOTE THE SAFE OPERATIONAL REQUIREMENTS, WARNINGS AND CAUTIONS. USE THE PRODUCT CORRECTLY AND WITH CARE FOR THE PURPOSE FOR WHICH IT IS INTENDED. FAILURE TO DO SO MAY CAUSE DAMAGE AND/OR PERSONAL INJURY AND WILL INVALIDATE THE WARRANTY. PLEASE KEEP INSTRUCTIONS SAFE FOR FUTURE USE.**

### 1. CONTENTS

	Page No.
Section 2. General	1.
Section 2.1 Identification	1.
Section 2.2. Technical Data	1.
Section 3. Safety/Operational Instructions	2.
Section 4. Maintenance/Examination/Inspection	2.
Section 5. Assembly and storage	3.
Section 6. Owner's & Operator's Responsibilities	3.
Section 7. Declaration of Conformity	4.
Section 8. Parts List/Diagram	5.

### 2. GENERAL

**2.1 Identification**  
 Supplier: Sealey Power Products,  
 Kempson Way,  
 Suffolk Business Park,  
 Bury St Edmunds,  
 Suffolk, IP32 7AR.

Model No: WF20.V3

**2.2 Technical Data**  
**Rated Capacity**  
 Safe Working Load (SWL) 2t (tested to 50% overload).  
 Working Load Limit (WLL) 2t (tested to 50% overload).

Lifting Cap. in Position 1: ..... 2000kg  
 Lifting Cap. in Position 2: ..... 1750kg  
 Lifting Cap. in Position 3: ..... 1650kg

Maximum Lift Ht. at Minimum Jib Extn:..... 2340mm  
 Maximum Lift Ht. at Maximum Jib Extn:..... 2500mm

Length of Jib Position 1: ..... 1275mm  
 Length of Jib Position 2: ..... 1420mm  
 Length of Jib Position 3: ..... 1570mm

Width inside frame (max) ..... 1035mm  
 Distance between rear wheel centres ..... 570mm  
 Weight ..... 173kg  
 Height/Length/Width (max) of frame: ..... 200/1900/1160mm  
 Overall height ..... 1720mm

- a) Design Capability: Test Load 50% overload.
- b) For a description of in-service and out-of-service conditions see section 3 Safety, Section 4 Maintenance and Section 6.
- c) For applications see Section 3 Safety.
- d) For control system, see Fig.1 for release valve and pump handle assy. Usage is explained in Section 3.2 Operation.
- e) For ground condition requirements, see Section 3 Safety.
- f) For information on parts and materials requiring specialised repair techniques see Section 4 Maintenance.

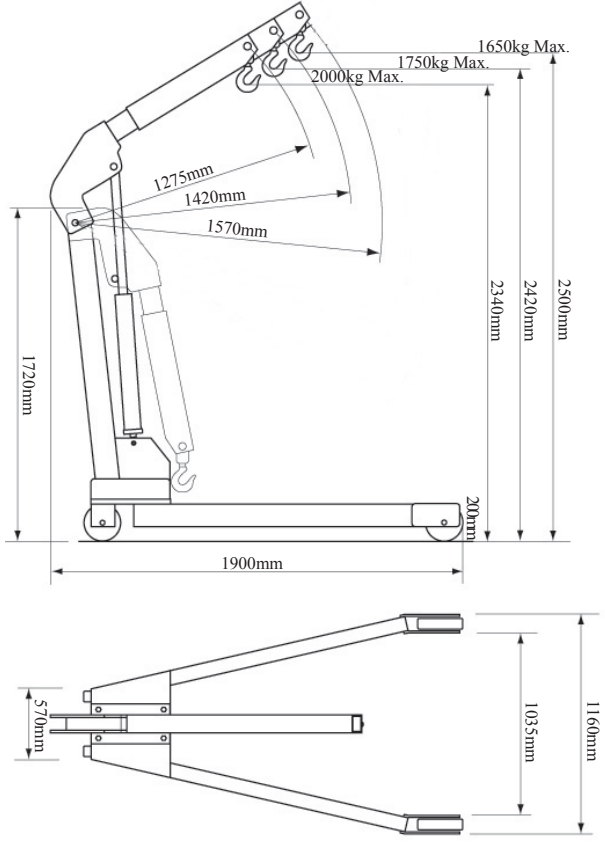
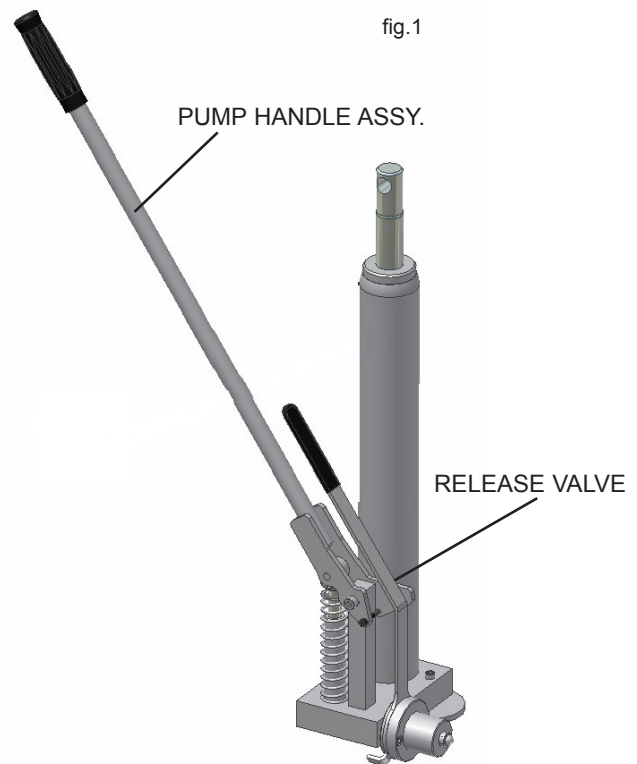

fig.1



### 3. SAFETY/OPERATING INSTRUCTIONS

#### 3.1 SAFETY

- ✓ **Keep** crane, lifting slings, support and beams in good working order and condition. Follow the inspection requirements as described in Section 4 page 2 Maintenance. *Take immediate action to repair or replace damaged parts by contacting your supplier. Ensure that all accessory lifting devices are suitably certified. If crane is damaged, remove from service immediately.*
- ✓ **Ensure the surface on which the crane is used is level, firm and capable of supporting the weight of the crane with maximum load - we recommend concrete. Never use the crane on tarmacadam or other soft surfaces.**
- ✓ **Ensure** the crane legs and arms are locked before use.
- ✓ **Keep** children and unauthorised persons away from the working area.
- ✓ **Keep** working area clean and tidy, free from unrelated materials and ensure that there is adequate lighting.
- ✓ **Ensure** that load does not exceed the maximum lifting capacity of the crane. Overloading the crane is dangerous. Where appropriate, use only the lifting points recommended by the manufacturer of the item to be lifted, e.g. vehicle engine.
- ✓ **Before** lifting the load ensure that the crane jib is in the lowest practical position, that there are no obstacles which may snag the load whilst it is being lifted and that the area above the jib is clear.
- ✓ **To avoid injury**, be fully aware of your own and other persons locations in relation to the lifting, and lowering, of the load.
- ✓ **Keep** a sound footing and balance, and ensure the floor is not slippery.
- ✓ **Ensure** jib extension is locked in position by means of the lock screw before attempting to lift.
- ✓ **Ensure** the centre of gravity always remains inside the crane base.
- ✗ **DO NOT** harness the load at an angle or use any attachments not verified as fit for purpose.
- ✗ **DO NOT** allow the load to swing during lifting.
- ✗ **DO NOT** allow the load to drop suddenly. Lower load with care, ensuring that you are fully aware of the condition of the surface onto which the load is to be placed.
- ✗ **DO NOT** load crane beyond its rated capacity for each specified jib extension position as indicated in Section 2 page 1. The capacity of the crane reduces as the jib is extended.
- ✗ **DO NOT** position any part of your body beneath the load.
- ✗ **DO NOT** use the crane to move or transport a load other than for repositioning (see 3.2.f). The crane is a lifting device only.
- ✗ **DO NOT** apply any sideways pressure to any part of the crane during lifting or when a load is suspended.
- ✗ **DO NOT** attempt to adjust the safety valve, which has been set and sealed by the manufacturer.
- ✗ **DO NOT** use this product to perform a task for which it is not designed.
- ✗ **DO NOT** use whilst under the influence of drugs, alcohol or intoxicating medication.
- ✗ **DO NOT** climb on the crane.
- ✓ **When** not in use fold the crane down and store in a safe, dry, childproof area.
- ✓ **This crane is designed for lifting within a garage or workshop environment.**
- ☐ **WARNING!** Failure to heed safety and warning instructions may result in damage and/or personal injury and will invalidate the warranty.



**NOTE: ENSURE YOU HAVE READ AND UNDERSTOOD THE SAFETY INSTRUCTIONS AT THE BEGINNING OF THIS SECTION BEFORE YOU OPERATE THE CRANE.**

#### 3.2 OPERATION. (Refer to Section 4.2 (a) regarding inspection before each and every use).

**Note!** Numbers in brackets refer to the parts diagram on page 4.

- ☐ **WARNING!** Ensure you have read and understood Section 1 Safety Instructions before using the crane.
- a) Pump the handle and the jib will rise, continue to pump until the jib reaches the appropriate height for the load.
- b) Connect the crane hook to the load using a suitable certified sling or support beam. Check that the hook safety latch is fully closed. Ensure that you are aware of the load weight and check that it is within the capacity of the crane at the jib extension you are using. When removing engines ensure you know the weight you are lifting and use only lifting points recommended by the vehicle manufacturer.
- c) Lift only directly above the load. ☐ **WARNING! DO NOT LIFT THE LOAD AT AN ANGLE!**
- d) To lower the load, operate the release lever (Fig.1). **VERY SLOWLY anti-clockwise** avoiding any sudden movement. **WARNING!** Do not allow the load to drop suddenly. Release lever to stop the descent.
- e) The crane is not a transportation device but may be used to reposition the load ready for working on. Before doing so, position the load as low as possible. **DO NOT** attempt to move in a sideways direction. The crane is not designed to sustain the load indefinitely. When you have positioned the load for working, lower it onto a secure work base, being fully aware of your own and other persons locations in relation to the descending load.
- f) When the load has been lowered and secured, remove the lifting harnesses etc. and place the crane in a safe location. Ensure that the the main piston is fully retracted (jib in lowest position).

### 4. MAINTENANCE/EXAMINATION/INSPECTION

**NOTE: The crane MUST be kept clean and dry and must be maintained in accordance with these instructions.**

#### 4.1. Lubrication.

- a) Oil all working parts monthly.
- b) The ram is filled with oil and should only require occasional topping up. For the occasional top up **DO NOT** use brake fluid, as this will damage the hydraulic seals. Proceed as follows:
  - a) Use only good quality hydraulic jack oil available from your supplier.
  - b) **DO NOT OVERFILL** as this will cause failure.
  - c) After filling with hydraulic oil, pump the crane up to full height and pour off any excess oil.

#### 4.2. Inspection and Examination of Crane Before Use.

- a) Before each use of the crane you must perform an inspection for leaks, damage, loose or missing parts.
- b) The workshop crane must be examined immediately if it has been subject to an abnormal load or shock. It is recommended that such an examination is made by an authorised service agent.
- c) The owner and/or operator must be aware that repair of this equipment will require specialised knowledge and facilities. It is recommended that an annual examination of the workshop crane is made by an authorised service agent.
- d) Unauthorised parts may be dangerous and will invalidate the warranty.

**Note!** Please see the Definition of 'inspection' and 'examination' below.

#### Inspection:

Looking at the crane for defects and checking the operation of the controls, limiting and indicating devices without loading the crane. This is much more than a check but does not normally require any part of the crane to be dismantled other than removal or opening of covers or housings.

**Examination:**

Verification that the crane can safely continue in service including a functional test of all safety devices i.e. limiting, indicating equipment, brakes, clutches, safety valves etc to verify that they operate within the required tolerances. An examination is more thorough than an inspection.

**5. ASSEMBLY/STORAGE INSTRUCTIONS**

**5.1 ASSEMBLY.**

**Note:** Numbers in brackets refer to item numbers as shown in the parts list.

Your crane is delivered assembled but with the legs in the folded position.

- a). Place swivel wheels (48) as shown (Fig.3). Lower the crane legs and lock them by passing the locking pins (45) through the legs into the frame and screwing into place.
- b). To purge any air that may have entered the hydraulic system turn the release valve handle (21) and at the same time pump handle (17) five to ten times. Release the handle.

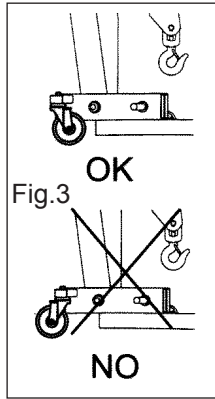

**5.2 STORAGE.**

- a) Always store the crane fully closed so that the jib is in lowest position and the ram is closed.
- b) To save space the legs may be folded into the upright position and secured in place using the Lock Pins. (Fig.2)

Fig.2

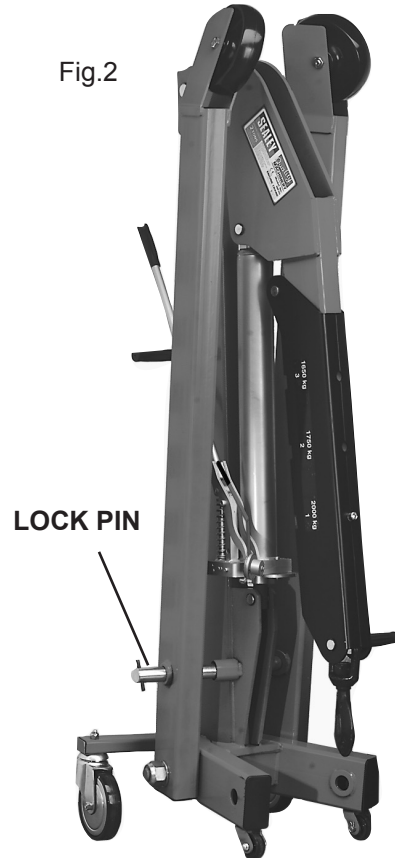

**6. OWNER'S & OPERATOR'S RESPONSIBILITIES**

*The owner and/or operator shall study these instructions and retain them for future use.*

- a) **Understanding instructions and warnings.**  
The owner and/or operator shall understand the operating instructions and warnings before operating the crane. Warning information must be emphasised and understood. If the operator is not fluent in English, the product instructions and warnings must be read to, and discussed with, the operator in the operator's native language by the owner, making sure the operator understands the contents.
- b) **Damaged Cranes.**  
Any crane which appears to be damaged, badly worn, or operates abnormally **MUST BE REMOVED FROM SERVICE!** It is recommended that necessary repairs be made by an authorised service agent.
- c) **End of service.**  
Through years of normal wear, the crane will eventually become unserviceable. When this happens ensure the hydraulic oil is drained off and disposed of in accordance with local authority regulations.

**Your crane is guaranteed for one year from the date of purchase. The Guarantee does not cover faults caused by incorrect use, lack of maintenance, accidental damage or damage caused to third parties through misuse. You are recommended to inform your insurers and check that adequate cover is in place. Warranty claims must be supported by a copy of the dated purchase receipt.**

**WARNING:** The warnings, cautions and instructions discussed in this manual cannot cover all possible conditions and situations that may occur. It must be understood that common sense and caution are factors which cannot be built into this product, but must be applied by the operator.

**NOTE:** It is our policy to continually improve products and as such we reserve the right to alter data, specifications and component parts without prior notice.

**IMPORTANT:** No liability is accepted for incorrect use of this product.

**WARRANTY:** Guarantee is 12 months from purchase date, proof of which will be required for any claim.

**INFORMATION:** For a copy of our latest catalogue and promotions call us on 01284 757525 and leave your full name and address, including postcode.



Sole UK Distributor, Sealey Group,  
Kempson Way, Suffolk Business Park,  
Bury St. Edmunds, Suffolk,  
IP32 7AR

01284 757500

www.sealey.co.uk

01284 703534

sales@sealey.co.uk

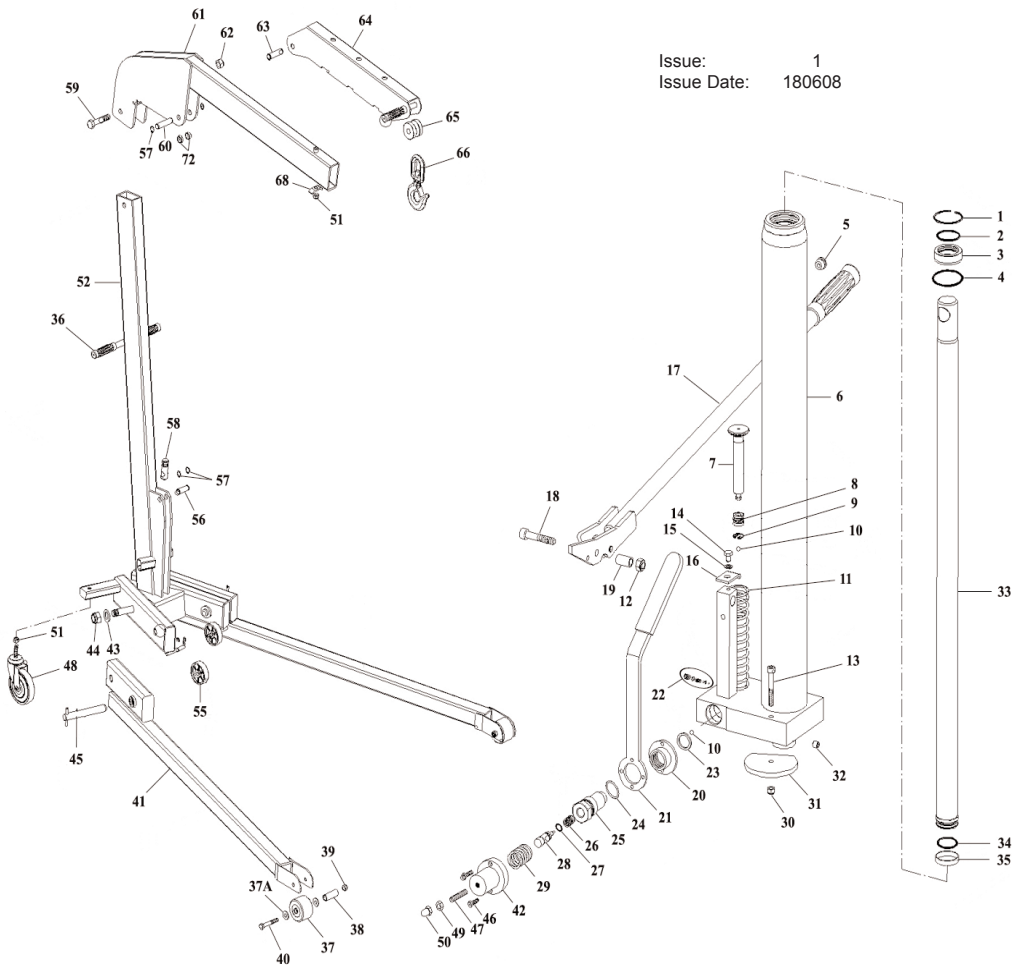

Issue: 1  
Issue Date: 180608

ITEM	PART NO	DESCRIPTION	ITEM	PART NO	DESCRIPTION
1	MG-12/1361	RING	35	MG-10/1164	RING
2	FC-20A/1348	O-RING	36	BM-04/1452	GRIP
3	FC-20A/1499	BUSHING	37	NC-15/1213	WHEEL
4	MGH-15/1136	O-RING	38	PH-15/1404	BUSHING
5	ME-12001/1139	PLUG	39	MI-10/1397	NUT
6	FC-20A/C25	HYDRAULIC CYLINDER	40	PH-15/1190	SCREW
7	FMG-300/1110	PUMP PISTON	41	FC-20A/C4	FRAME
8	TJ-2/1133	SEAL	42	FC-5A-2298	RELEASE VALVE CAP
9	MGG-500/1161	SPRING	43	FC-20/1649	WASHER
10	ME-1501/1149	STEEL BALL	44	FC-20/1648	NUT
11	AP-100/1241	SPRING	45	FC-20/1657	LOCKING PIN
12	EF-1.5/1318	NUT	46	CSR-55-1634	SCREW
13	ND-2/1814	SCREW	47	FC-5A-1246	SET SCREW
14	FC-10A/1470	SCREW	48	FC-20/1214	CASTOR WHEEL
15	FC-10A/1249	WASHER	49	FC-5A-1532	SCREW
16	FC-10A/1279	STOP	50	FC-5A-2150	SCREW
17	FC-10A/C21	HANDLE	51	MB-22-B/1398	NUT
18	AP-100/1345-A	SCREW	52	FC-20A/C23	UPRIGHT
19	FMG-300A/1475	BUSHING	55	W-1/1214	WHEEL
20	FC-5A-2297	RELEASE HANDLE SUPPORT	56	FC-20A/1189	PIN
21	FC-5A-1369	RELEASE HANDLE	57	MI-10/1377	RETAINING RING
22	MG-2/C9	SAFETY VALVE	58	FC-20A/1122-1	MOUNTING PIN
23	TJ-2/1120	WASHER	59	PH-15/1191	SCREW
24	MG-3/1134	O-RING	60	FC-20A/1194	PIN
25	FC-10A/C42	NUT	61	FC-20A/C3	JIB
26	TJ-2/1527	SPRING	62	PH-15/1216	NUT
27	ME-1501/1132	O-RING	63	PH-15/1141	PIN
28	TJ-1.5/1125	RELEASE ROD	64	FC-20A/1158	JIB EXTENSION
29	FC-5A-2296	SPRING	65	NC-15/1407	BUSHING
30	FMG-300A/1318	NUT	66	NC-20A/1166	HOOK
31	FC-20A/1669	STOP	68	NC-20A/1638	PLATE
32	MA-2/2142	SCREW	72	FC-20/1180	BUSHING
33	FC-20A/C14	MAIN PISTON	73	RFC-20A	REPAIR KIT
34	MG-10/1134	O-RING	74	FC-20A/C2	HYDRAULIC UNIT

**NOTE:** It is our policy to continually improve products and as such we reserve the right to alter data, specifications and component parts without prior notice.

**IMPORTANT:** No liability is accepted for incorrect use of this product.

**WARRANTY:** Guarantee is 12 months from purchase date, proof of which will be required for any claim.

**INFORMATION:** For a copy of our latest catalogue and promotions call us on 01284 757525 and leave your full name and address, including postcode.



Sole UK Distributor, Sealey Group,  
Kempson Way, Suffolk Business Park,  
Bury St. Edmunds, Suffolk,  
IP32 7AR

01284 757500

www.sealey.co.uk

01284 703534

sales@sealey.co.uk