

Thank you for purchasing a Sealey product. Manufactured to a high standard this product will, if used according to these instructions and properly maintained, give you years of trouble free performance.

IMPORTANT: PLEASE READ THESE INSTRUCTIONS CAREFULLY. NOTE THE SAFE OPERATIONAL REQUIREMENTS, WARNINGS & CAUTIONS. USE THE PRODUCT CORRECTLY AND WITH CARE FOR THE PURPOSE FOR WHICH IT IS INTENDED. FAILURE TO DO SO MAY CAUSE DAMAGE OR PERSONAL INJURY AND WILL INVALIDATE THE WARRANTY. PLEASE KEEP INSTRUCTIONS SAFE FOR FUTURE USE.

1. CONTENTS

	Page No.
Section 2. General	1.
Section 2.1 Identification	1.
Section 2.2. Technical Data	1.
Section 3. Safety/Operational Instructions	2.
Section 4. Maintenance/Examination/Inspection	2.
Section 5. Assembly/storage and priming	3.
Section 6. Owner's & Operator's Responsibilities	3.
Section 7. Declaration of Conformity	4.
Section 8. Parts List/Diagram	5.

2. GENERAL

2.1. Identification

Supplier: Sealey Power Products,
Kempson Way,
Suffolk Business Park,
Bury St Edmunds,
Suffolk, IP32 7AR.

Model No: WD302

2.2. Technical Data

Rated Capacity

Safe Working Load (SWL) 3t (tested to 50% overload).
Working Load Limit (WLL) 3t (tested to 50% overload).

Lifting Cap. in Position 1: 3000kg
Lifting Cap. in Position 2: 2500kg
Lifting Cap. in Position 3: 2300kg

Maximum Lift Ht. at Minimum Jib Extn: ... 2760mm
Maximum Lift Ht. at Maximum Jib Extn: ... 2920mm

Length of Jib Position 1: 1620mm
Length of Jib Position 2: 1765mm
Length of Jib Position 3: 1910mm
Height of Frame: 265mm
Length of Frame: 2150mm
Overall Height: 2000mm
Maximum Width of Frame: 1290mm
Width Inside Frame: 1120mm
Weight: 302kg

- Design Capability: Test Load 50% overload.
- For a description of in-service and out-of-service conditions see section 3 Safety, Section 4 Maintenance and Section 6.
- The crane is fitted with a bypass valve that will prevent the ram from over extending.
- For applications see Section 3 Safety.
- For control system, see Fig.1 for release valve and pump handle assy. Usage is explained in Section 3.2 Operation.
- For ground condition requirements, see Section 3 Safety.
- For information on parts and materials requiring specialised repair techniques see Section 4 Maintenance.

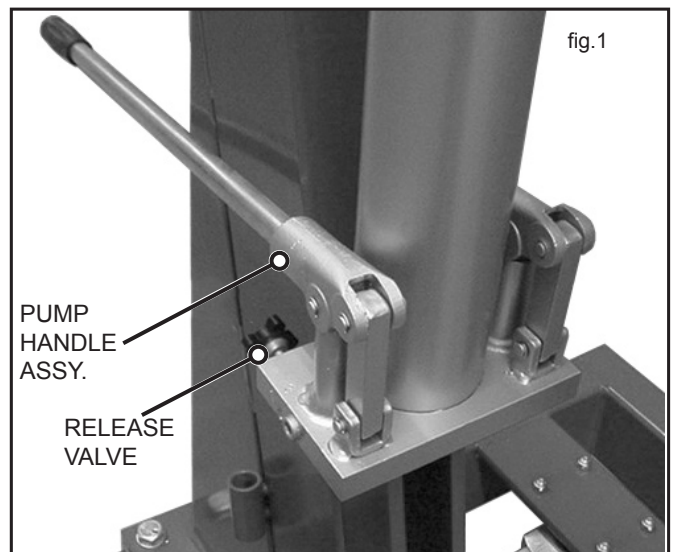
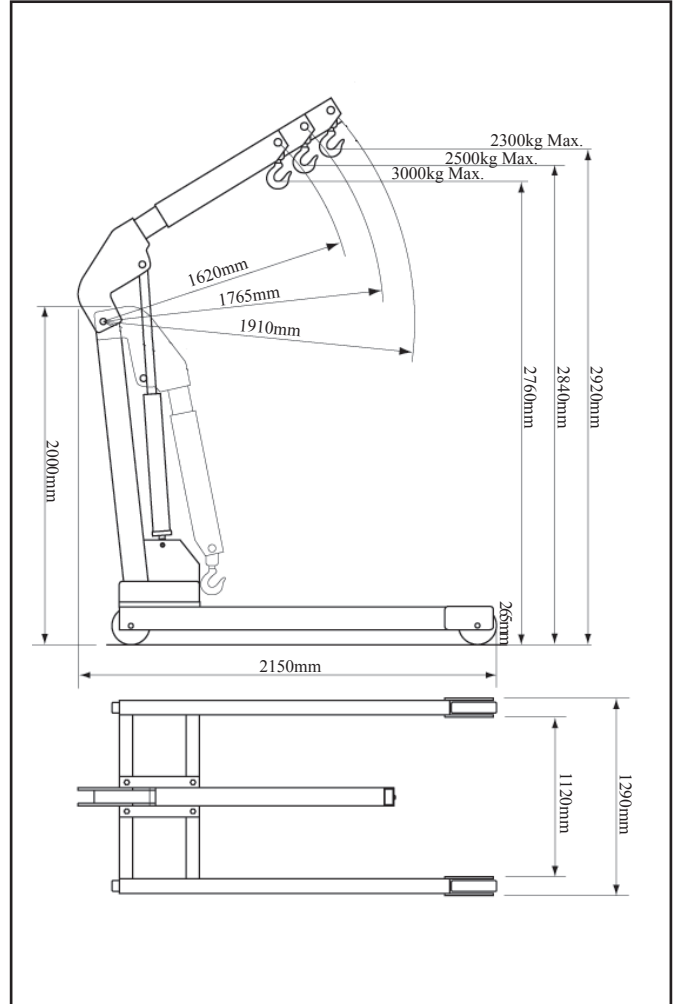

3. SAFETY/OPERATING INSTRUCTIONS

3.1. SAFETY

- 3 **Keep** crane, lifting slings, support and beams in good working order and condition. Follow the inspection requirements as described in Section 4 page 2 Maintenance. *Take immediate action to repair or replace damaged parts by contacting your supplier. Ensure that all accessory lifting devices are suitably certified. If crane is damaged, remove from service immediately.*
- 3 **Ensure the surface on which the crane is used is level, firm and capable of supporting the weight of the crane with maximum load - we recommend concrete. Never use the crane on tarmac or other soft surfaces.**
- 3 **Ensure** the crane legs and arms are locked before use.
- 3 **Keep** children and unauthorised persons away from the working area.
- 3 **Keep** working area clean and tidy, free from unrelated materials and ensure that there is adequate lighting.
- 3 **Ensure** that load does not exceed the maximum lifting capacity of the crane. Overloading the crane is dangerous. Where appropriate, use only the lifting points recommended by the manufacturer of the item to be lifted, e.g. vehicle engine.
- 3 **Before** lifting the load ensure that the crane jib is in the lowest practical position, that there are no obstacles which may snag the load whilst it is being lifted and that the area above the jib is clear.
- 3 **To** avoid injury, be fully aware of your own and other persons locations in relation to the lifting, and lowering, of the load.
- 3 **Keep** a sound footing and ensure the floor is not slippery.
- 3 **Ensure** jib extension locking bolt and nut are in position before lifting.
- 3 **Ensure** the centre of gravity always remains inside the crane base.
- 7 **DO NOT** harness the load at an angle or use any attachments not verified as fit for purpose.
- 7 **DO NOT** allow the load to swing during lifting.
- 7 **DO NOT** allow the load to drop suddenly. Lower load with care, ensuring that you are fully aware of the condition of the surface onto which the load is to be placed.
- 7 **DO NOT** load crane beyond its rated capacity for each specified jib extension position as indicated in Section 2 page 1. The capacity of the crane reduces as the jib is extended.
- 7 **DO NOT** position any part of your body beneath the load.
- 7 **DO NOT** use the crane to move or transport a load other than for repositioning (see 3.2.f). The crane is a lifting device only.
- 7 **DO NOT** apply any sideways pressure to any part of the crane during lifting or when a load is suspended.
- 7 **DO NOT** attempt to adjust the safety valve, which has been set and sealed by the manufacturer.
- 7 **DO NOT** use this product to perform a task for which it is not designed.
- 7 **DO NOT** use whilst under the influence of drugs, alcohol or intoxicating medication.
- 7 **DO NOT** climb on the crane.
- 3 **When** not in use fold the crane down and store in a safe, dry, childproof area.
- 3 **This crane is designed for lifting within a garage or workshop environment.**
- WARNING! Failure to heed safety and warning instructions may result in damage and/or personal injury and will invalidate the warranty.**



NOTE: ENSURE YOU HAVE READ AND UNDERSTOOD THE SAFETY INSTRUCTIONS AT THE BEGINNING OF THIS SECTION BEFORE YOU OPERATE THE CRANE.

- 3.2. **OPERATION. (Refer to Section 4.2 (a) regarding inspection before each and every use).** (No's refer to Parts Diagram Page 5).
- a) Refer to the lifting capacity chart in Section 2.2 (Technical Data). If necessary adjust the position of the jib extension to cater for the weight that is to be lifted. To adjust the jib extension remove the clip (50) and pin (49) and slide the jib in or out as required to the next position. Replace the clip and pin in the new position. Close the release valve by turning knob (12) clockwise (see fig.1)
- b) Screw the pump handle into either of the two available pumping positions and commence pumping to raise the jib to the height at which the load will be secured.
- c) Connect the crane hook to the load using a suitable certified sling or support beam. When removing engines use only lifting points recommended by the vehicle manufacturer.
- d) Lift only directly above the load. **WARNING! DO NOT LIFT THE LOAD AT AN ANGLE!**
- e) To lower the load turn the release valve knob slowly anticlockwise. The load will descend at a controlled rate and can be stopped by turning the knob clockwise to close the valve.
- f) The crane is not a transportation device but may be used to reposition the load ready for working on. To do so, lower the load and jib to the lowest possible point before attempting to move. Do not attempt to move in a sideways direction. The crane is not designed to sustain the load indefinitely. When you have positioned the load for working, fully lower the load onto a secure and appropriate working base, being fully aware of your own and other persons location in relation to the lowering load.
- g) When the load has been successfully lowered and secured, remove the securing harnesses etc. and place the crane in an appropriately safe location having ensured the jib is fully lowered.

4. MAINTENANCE/EXAMINATION/INSPECTION

NOTE: The crane MUST be kept clean and dry and must be maintained in accordance with these instructions.

4.1. Lubrication.

- a) Oil all working parts monthly.
- b) The ram is filled with oil and should only require occasional topping up. For the occasional top up DO NOT use brake fluid, as this will damage the hydraulic seals. Proceed as follows:
 - a) Use only good quality hydraulic jack oil available from your supplier.
 - b) DO NOT OVERFILL as this will cause failure.
 - c) After filling with hydraulic oil, pump the crane up to full height and pour off any excess oil.

4.2. Inspection and Examination of Crane Before Use.

- a) Before each use of the crane you must perform an inspection for leaks, damage, loose or missing parts.
- b) The workshop crane must be examined immediately if it has been subject to an abnormal load or shock. It is recommended that such an examination is made by an authorised service agent.
- c) The owner and/or operator must be aware that repair of this equipment will require specialised knowledge and facilities. It is recommended that an annual examination of the workshop crane is made by an authorised service agent.
- d) Unauthorised parts may be dangerous and will invalidate the warranty.

Note! Please see the Definition of 'inspection' and 'examination' page 3.

Inspection:

Looking at the crane for defects and checking the operation of the controls, limiting and indicating devices without loading the crane. This is much more than a check but does not normally require any part of the crane to be dismantled other than removal or opening of covers or housings.

Examination:

Verification that the crane can safely continue in service including a functional test of all safety devices i.e. limiting, indicating equipment, brakes, clutches, safety valves etc to verify that they operate within the required tolerances. An examination is more thorough than an inspection.

5. ASSEMBLY / PRIMING / STORAGE INSTRUCTIONS

5.1. ASSEMBLY.

Note: Numbers in brackets refer to item numbers as shown in the parts diagram (Section 8, page 5).

WARNING! Due to its weight at least 3 able-bodied people will be required to unpack and assemble this crane.

5.1. ASSEMBLY. To identify item numbers refer to the parts diagram (Section 8, page 5).

- 5.1.2. Remove the top and sides of the wooden transit crate and lift out the main arm and jib components.
 - 5.1.3. Lift and support the open end of the main frame. Attach a fixed wheel (34) to each fork using axle (35) and clip (36). Lower the frame back to the ground.
 - 5.1.4. Lift and support the other end of the main frame. Attach a castor wheel (39) to each cross plate using 4 bolts (38) and 4 nuts (37) on each wheel. Lower the frame back to the ground and chock the wheels to prevent the frame moving.
 - 5.1.5. Take the main upright (44) (with ram attached) and place it upright onto the two cross members of the main frame. Align the footplate holes with the holes in the frame and secure with five bolts (41) and five washers (40).
 - 5.1.6. Remove the clip (50) and pin (49) that retain the jib extension and slide the extension off the end of the arm. Lift the arm and support it over the top end of the upright. Align the pivot holes in both parts and slide the pivot bolt (45) through and secure with bolt (46).
 - 5.1.7. Lift up the arm and support it in an approximate horizontal position. Hinge the ram unit away from the upright and align the hole in the end of the ram shaft with the hole in the arm. Slide the pivot bolt (47) into position and secure with retaining ring (48).
 - 5.1.8. Slide the jib extension back onto the arm and secure it by replacing the pin (49) and clip (50) into one of the 3 designated jib fixing positions.
 - 5.1.9. Attach the black manoeuvring handle (44) to the back of the main upright using the two hex socket cap screws provided.
 - 5.1.10. Remove the pumping handle from its stowage position on the side of the main upright and screw it in to one of the pump positions.
- 5.2. PRIMING THE UNIT.** Before first use it is necessary to prime the hydraulic system as follows:
- 5.2.1. Open the release valve by turning the knob (12) anticlockwise. (See fig.1.) Operate the pumping handle up and down 5 to 6 times. Close the release valve. The crane is now ready for use.
- 5.3. STORAGE.**
- a) Always store the crane fully closed so that the jib is in lowest position and the ram is closed.

6. OWNER'S & OPERATOR'S RESPONSIBILITIES

The owner and/or operator shall study these instructions and retain them for future use.

- a) **Understanding instructions and warnings.**
The owner and/or operator shall understand the operating instructions and warnings before operating the crane. Warning information must be emphasised and understood.
If the operator is not fluent in English, the product instructions and warnings must be read to, and discussed with, the operator in the operator's native language by the owner, making sure the operator understands the contents.
- b) **Damaged Cranes.**
Any crane which appears to be damaged, badly worn, or operates abnormally **MUST BE REMOVED FROM SERVICE!** It is recommended that necessary repairs be made by an authorised service agent.
- c) **End of service.**
Through years of normal wear, the crane will eventually become unserviceable. When this happens ensure the hydraulic oil is drained off and disposed of in accordance with local authority regulations.

WARNING! The warnings, cautions and instructions discussed in this manual cannot cover all possible conditions and situations that may occur. It must be understood that common sense and caution are factors which cannot be built into this product, but must be applied by the operator



7. DECLARATION OF CONFORMITY

Declaration of Conformity:

**FIXED FRAME CRANE
MODEL No: WD302**

2006/42/EC Machinery Directive
93/68/EEC CE Marking Directive
Health & Safety at Work Act 1974
Lifting Operations & Lifting Equipment Regulations (LOLER) 1998
EN292-2 1991



We, the sole importer into the UK, declare that the product listed below is in conformity with the following standards and directives. The construction file for this product is held by the Manufacturer and may be inspected, by a national authority, upon request to Jack Sealey Ltd.

Signed by Mark Sweetman

1st March 2008

For Jack Sealey Ltd. Sole importer into the UK of Sealey Power Products.

Your crane is guaranteed for one year from the date of purchase. The Guarantee does not cover faults caused by incorrect use, lack of maintenance, accidental damage or damage caused to third parties through misuse. You are recommended to inform your insurers and check that adequate cover is in place. Warranty claims must be supported by a copy of the dated purchase receipt.

NOTE: It is our policy to continually improve products and as such we reserve the right to alter data, specifications and component parts without prior notice.

IMPORTANT: No liability is accepted for incorrect use of product.

WARRANTY: Guarantee is 12 months from purchase date, proof of which will be required for any claim.

INFORMATION: For a copy of our latest catalogue and promotions call us on 01284 757525 and leave your full name and address, including postcode.

	<p>Sole UK Distributor Sealey Group, Bury St. Edmunds, Suffolk.</p>	<p>01284 757500</p>	<p>www.sealey.co.uk</p>
	<p>01284 703534</p>	<p>sales@sealey.co.uk</p>	

8. PARTS LIST/DIAGRAM

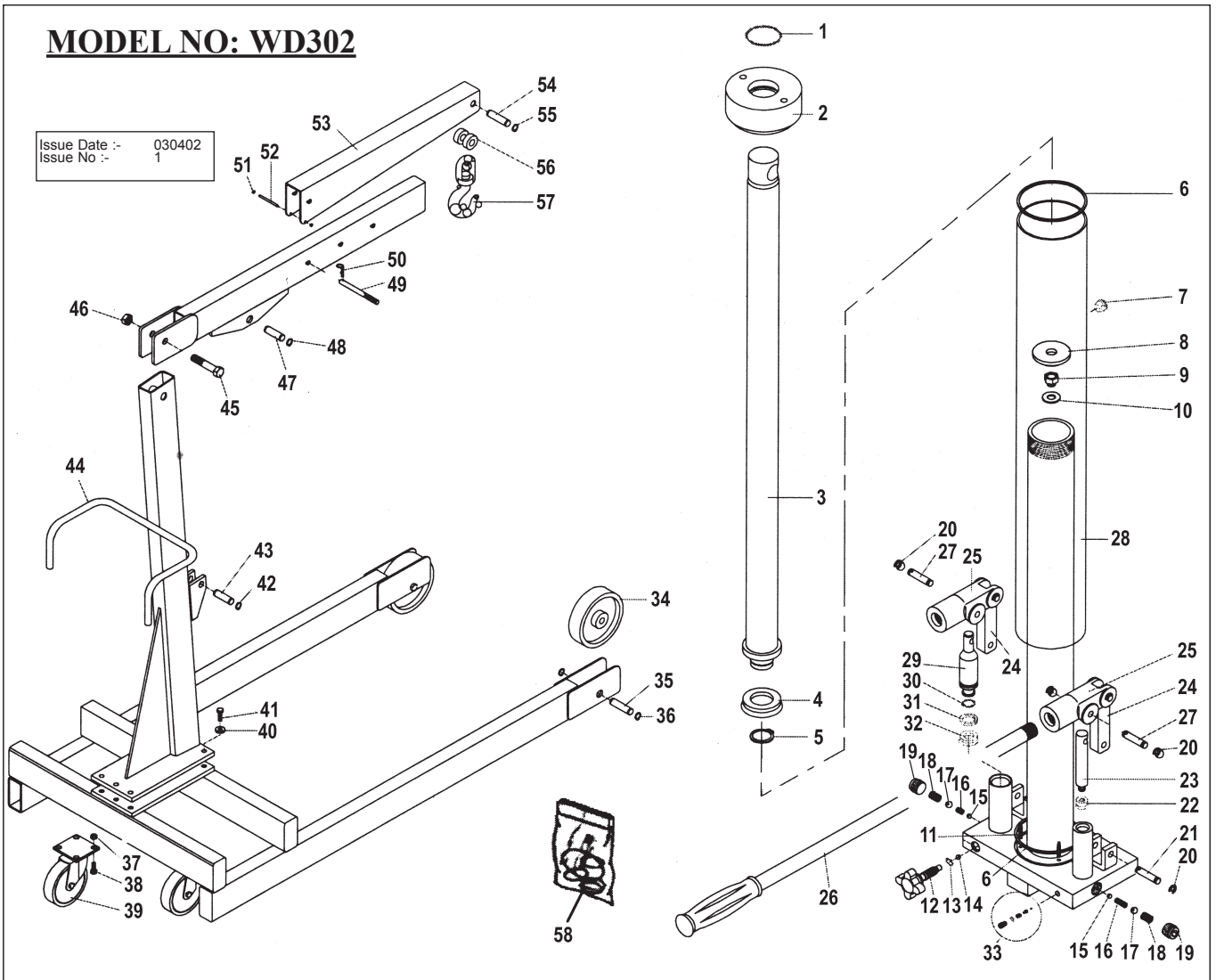

Item	Part No.	Description
1	MG-10/1131	O-RING
2	NC-31/1102	RING
3	NC-30/1105	PISTON
4	ME12001/1134H	SEAL
5	Y-10/1114	CIRCLIP
6	W-22/1135	O-RING
7	ME-12001/1139	FILLER PLUG
8	NC-30/2124	WASHER
9	TS-1.5/2096	SCREW
10	NS-1/1530	WASHER
11	MG-2/1457	FILTER
12	PH-5/1125	RELEASE
13	ME-1501/1212	O-RING
14	ME-1501/1149	BALL
15	ME-1501/1149	BALL
16	ME-1501/1161	SPRING
17	ME-1501/1212	O-RING
18	ME-1501/1162	SPRING
19	Y-2/1160	SCREW
20	MB-22-A/1286	CIRCLIP

Item	Part No.	Description
21	PH-5/1344	AXLE
22	TJ-2/113	SEAL
23	MGG-500/1110	PUMP PISTON
24	PH-5/1111	JOINT
25	PH-5/1112	HANDLE SOCKET
26	BM-3/1113	HANDLE
27	B-3/1344	AXLE
28	FC-20/1103	COVER
29	NC-30/1478	PUMP PISTON
30	TR-2/1289	O-RING
31	EF-1200/1127	RING
32	ME-1501/1134	AXLE
33	MG-2/C9	SAFETY VALVE
34	NC-30/1213	WHEEL
35	NC-30/1190	AXLE
36	MB-34-B/1343	RETAINER RING
37	MB-21-B/1398	NUT
38	EH-10/1742	SCREW
39	NC-30/1214	WHEEL
40	PTM-2/1552	WASHER

Item	Part No.	Description
41	NC-30/1670	SCREW
42	MI-10/1377	RETAINER RING
43	PH-15/1141	AXLE
44	NC-30/1155	HANDLE BAR
45	NC-30/1191	SCREW
46	MB-39-B/1405	NUT
47	PTF-1000/1194	AXLE
48	MI-10/1377	RETAINER RING
49	PH-15/1121	AXLE
50	MI-5/1159	CIRCLIP
51	ME-1501/1286	CIRCLIP
52	NC-30/1314	AXLE
53	NC-30/1158	ARM EXTENSION
54	NC-30/1141	AXLE
55	MI-10/1377	RETAINER RING
56	NC-30/1407	WASHER
57	NC-30/1116	HOOK
58	RHC-30	REPAIR KIT
59	NC-30/C2	HYDRAULIC UNIT COMPLETE



Sole UK Distributor
Sealey Group,
Bury St. Edmunds, Suffolk.

01284 757500
01284 703534

www.sealey.co.uk
sales@sealey.co.uk