



85L WHEELBARROW

MODEL NO: **WB85**

Thank you for purchasing a Sealey product. Manufactured to a high standard, this product will, if used according to these instructions, and properly maintained, give you years of trouble free performance.

IMPORTANT: PLEASE READ THESE INSTRUCTIONS CAREFULLY. NOTE THE SAFE OPERATIONAL REQUIREMENTS, WARNINGS & CAUTIONS. USE THE PRODUCT CORRECTLY AND WITH CARE FOR THE PURPOSE FOR WHICH IT IS INTENDED. FAILURE TO DO SO MAY CAUSE DAMAGE AND/OR PERSONAL INJURY AND WILL INVALIDATE THE WARRANTY. KEEP THESE INSTRUCTIONS SAFE FOR FUTURE USE.



Refer to instructions



Wear protective gloves



Wear safety footwear

1. SAFETY

- ✓ Always distribute the load evenly over the surface of the wheelbarrow.
- ✗ **DO NOT** overload the wheelbarrow.
- ✗ **DO NOT** use wheelbarrow on uneven ground and **DO NOT** run over curbs or steps - use a ramp.
- ✗ **DO NOT** allow others to ride in the wheelbarrow.
- ✗ **DO NOT** use the wheelbarrow if any part is damaged, paying particular attention to the wheel.
- ✗ **DO NOT** inflate the tyre to more than 25psi.

2. INTRODUCTION

Manufactured from heavy-duty composite material. Ideal for a wide range of gardening and light construction tasks as well as general domestic use. Constructed with strong tubular steel frame and rubber grip handles. Fitted with 405mm pneumatic tyre.

3. SPECIFICATION

Model No.: WB85
 Capacity 85L
 Capacity (Weight) 150kg

4. CONTENTS

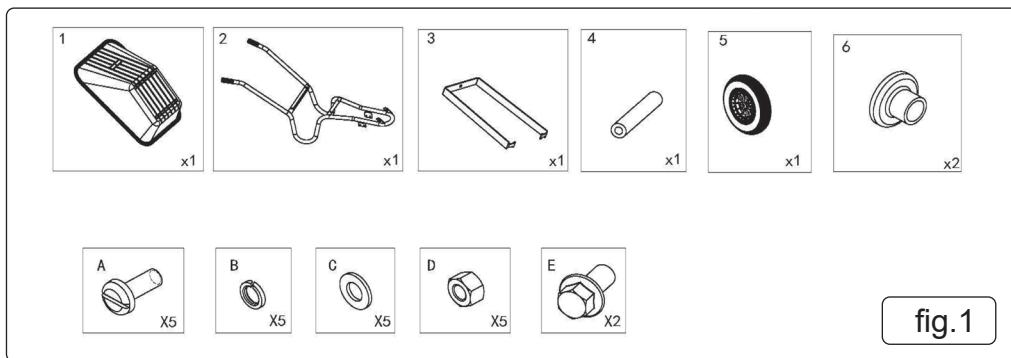

5. ASSEMBLY

NOTE: Component package is wrapped in film and placed inside the cross member of the frame (fig.1.2).

5.1. FRAME AND PAN SUPPORT (fig.2)

- 5.1.1. Carefully remove plastic wrapping from the frame.
- 5.1.2. Carefully remove component package from cross member.
- 5.1.3. The pan support arm (fig.1.3) is already engaged with the frame. This will need adjustment at the final stage of assembly.

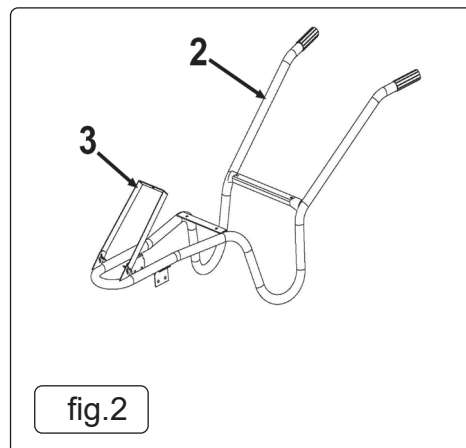

5.2. WHEEL ASSEMBLY (fig.3)

- 5.2.1. Assemble shaft (fig.1.4) into wheel hub and place between the wheel mounting brackets. Align the shaft with either of the two holes in the mounting brackets.
- 5.2.2. Place plastic caps (fig.1.6) onto wheel hub centres and engage bolt and washer arrangement (fig.1.E) in shaft. Tighten bolts to secure in place

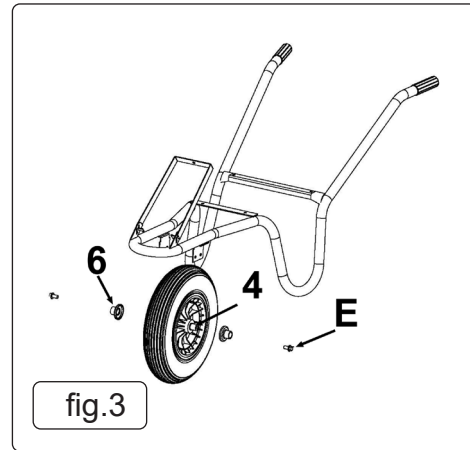

5.3. PAN AND FRAME ASSEMBLY (fig.4)

- 5.3.1. Partially invert pan to allow internal access to the fixing holes.
 - 5.3.2. Pass screws (fig.1. A) from inside the pan, through the frame fixing holes, and engage plain washer, spring washer and nut pack (fig.1.D / B / C) on outside.
- × **DO NOT** tighten the fixings until all fixings, including the one shown in fig.5, are in place and engaged.

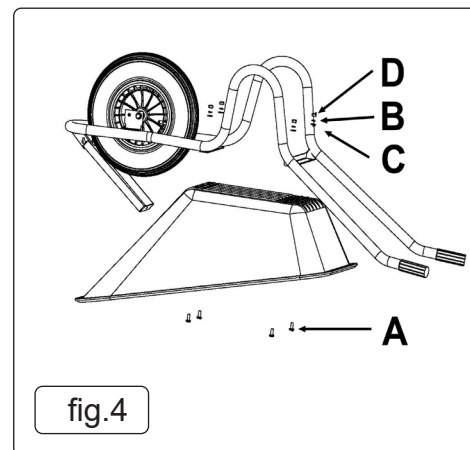

5.4. FRONT SUPPORT ASSEMBLY (fig.5)

- 5.4.1. Adjust the location of the support to enable alignment of the hole in the support to match with the fixing hole in the pan.
- 5.4.2. Pass the screw (fig.1.A) through the pan from the inside to the outside and engage plain washer, spring washer and nut pack (fig.1.D / B / C).

5.5. FINAL ASSEMBLY

- 5.5.1. With all fixings in place apply final tightening to all fixings.
- × **DO NOT** over tighten.

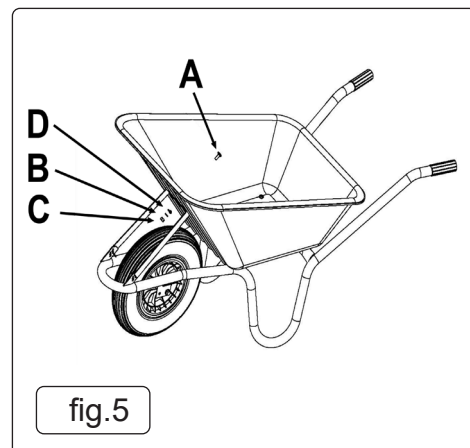

Parts support is available for this product. Please email sales@sealey.co.uk or telephone 01284 757500



ENVIRONMENT PROTECTION

Recycle unwanted materials instead of disposing of them as waste. All tools, accessories and packaging should be sorted, taken to a recycling centre and disposed of in a manner which is compatible with the environment. When the product becomes completely unserviceable and requires disposal, drain any fluids (if applicable) into approved containers and dispose of the product and fluids according to local regulations.

Note: It is our policy to continually improve products and as such we reserve the right to alter data, specifications and component parts without prior notice.

Important: No Liability is accepted for incorrect use of this product.

Warranty: Guarantee is 12 months from purchase date, proof of which is required for any claim.

Sealey Group, Kempson Way, Suffolk Business Park, Bury St Edmunds, Suffolk. IP32 7AR



01284 757500



01284 703534



sales@sealey.co.uk



www.sealey.co.uk