

Thank you for purchasing a Kubota product. Manufactured to a high standard, this product will, if used according to these instructions, and properly maintained, give you years of trouble free performance.

**IMPORTANT: PLEASE READ THESE INSTRUCTIONS CAREFULLY. NOTE THE SAFE OPERATIONAL REQUIREMENTS, WARNINGS & CAUTIONS. USE THE PRODUCT CORRECTLY AND WITH CARE FOR THE PURPOSE FOR WHICH IT IS INTENDED. FAILURE TO DO SO MAY CAUSE DAMAGE AND/OR PERSONAL INJURY AND WILL INVALIDATE THE WARRANTY. KEEP THESE INSTRUCTIONS SAFE FOR FUTURE USE.**



Refer to instruction manual

### 1. SAFETY

- WARNING!** Ensure Health & Safety, local authority, and general workshop practice regulations are adhered to when using this product.
- × **DO NOT** open more than one drawer at a time.
- × **DO NOT** step on the drawers.
- × **DO NOT** let children play with the roll cab.
- ✓ Ensure all drawers are fully closed and the self locking catches are activated, before moving the toolbox.
- ✓ Secure the brakes when rollcab is in the desired position.
- ✓ Keep the work area clean, uncluttered and ensure there is adequate lighting.
- × **DO NOT** use in damp work areas.
- WARNING!** The warnings, cautions and instructions referred to in this instruction manual cannot cover all possible conditions and situations that may occur. It must be understood that common sense and caution are factors which cannot be built into this product, but must be applied by the operator.



### 2. INTRODUCTION

Heavy gauge steel with double wall construction for extra strength and durability. Ball-bearing drawer slides provide superior performance and carry heavier loads. Each drawer fitted with catch to prevent unexpected opening when being transported around the workshop. Added security provided by side mounted cylinder lock, supplied with two keys. Rubber grip side handles for comfort and ease when manoeuvring. Unique design incorporates perforated side panels for hanging tools and accessories. Ideally suited for the Premier range of Modular Tool Trays. Rust and solvent resistant powder coated finish. Fitted with anti-shock protection on all four corners to prevent accidental damage. Rollcabs feature two Ø125mm swivel castors with large toe locks and two fixed wheels. Tough composite top for fitting and securing topchest or can be used as a workstation. Comprehensive range of accessories available.

### 3. SPECIFICATION

Model No:..... **W25US04507**  
 Overall Size:..... 765 x 465 x 960mm  
 Medium Drawer (x6):..... 535 x 400 x 60mm  
 Large Drawer (x2):..... 535 x 400 x 130mm

### 4. OPERATION

- 4.1. Each drawer is fitted with a catch mechanism on the right hand side, underneath the handle.
- 4.2. To open a drawer, push the catch to the left to release it and pull the drawer open (fig.1).
  - WARNING!** Only open one drawer at a time and **DO NOT** overload the drawers.
  - NOTE:** The maximum weight is 25kg for the medium drawers, and 35kg for the large drawers.
- 4.3. When moving the rollcab, ensure that the drawers are closed and locked (fig.2) to prevent accidental opening.
- 4.4. Release the brakes as shown in fig.3 and move the rollcab using the handles to maintain full control.
- 4.5. When the rollcab has been moved to the required location, lock the brakes.
  - WARNING!** **DO NOT** move across slopes of more than 5° as the rollcab may tilt over.

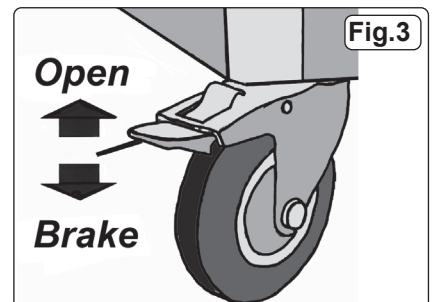
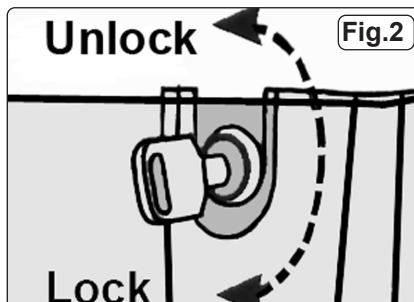
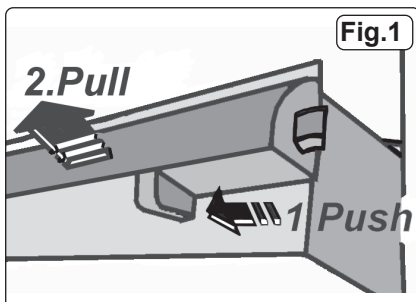



#### **ENVIRONMENT PROTECTION**

Recycle unwanted materials instead of disposing of them as waste. All tools, accessories and packaging should be sorted, taken to a recycling centre and disposed of in a manner which is compatible with the environment. When the product becomes completely unserviceable and requires disposal, drain any fluids (if applicable) into approved containers and dispose of the product and fluids according to local regulations.

**Note:** It is our policy to continually improve products and as such we reserve the right to alter data, specifications and component parts without prior notice.

**Important:** No liability is accepted for incorrect use of this product.

**Kubota, Dormer Rd, Thame, Oxfordshire, OX9 3UN**



**01844 268000**



**www.kubota.com**