

Thank you for purchasing a Sealey product. Manufactured to a high standard this product will, if used according to these instructions and properly maintained, give you years of trouble free performance.



IMPORTANT: PLEASE READ THESE INSTRUCTIONS CAREFULLY. NOTE THE SAFE OPERATIONAL REQUIREMENTS, WARNINGS AND CAUTIONS. USE THE PRODUCT CORRECTLY AND WITH CARE FOR THE PURPOSE FOR WHICH IT IS INTENDED. FAILURE TO DO SO MAY CAUSE DAMAGE AND/OR PERSONAL INJURY AND WILL INVALIDATE THE WARRANTY. PLEASE KEEP INSTRUCTIONS SAFE FOR FUTURE USE.

1. SAFETY INSTRUCTIONS

- ✓ Always lower, centre and chain wheel before attempting to move trolley.
- ✓ Only use the trolley on firm, level, unobstructed surfaces which are capable of supporting the trolley and wheel.
- x Do not overload the trolley - maximum capacity is **1000kg**.
- x Do not allow others to ride on the trolley.
- x Do not use on tarmac/adam. The trolley must only be used on a concrete surface.
- ✓ Replace or repair damaged parts. *Use only recommended parts. Unauthorised parts may be dangerous and will invalidate the warranty.*
- ✓ Use a qualified person to lubricate and maintain the trolley. **DO NOT** use brake fluid to top up hydraulic unit. Use Sealey hydraulic oil only.
- **Warning!** Failure to comply with these instructions may result in loss of load, damage to trolley or other property and/or personal injury.

2. INTRODUCTION & SPECIFICATION

The W100T is suitable for changing wheels and tyres on the very largest vehicles. Load bearing arms incorporate smooth roller action sleeves allowing wheel to be rotated for lining up on studs. Foot operated hydraulic mechanism with 'dead man' control release. Mounted on 2 swivel and 2 fixed castors for manoeuvrability. Supplied with safety chain.

Specification

Maximum Load	1000kg	Width Between Rollers	760mm
Min. Lift Height	150mm	Roller Length	610mm
Max. Lift Height	750mm	Hydraulic Oil Capacity	0.8 litres

3. OPERATING INSTRUCTIONS

- 3.1. Before first use:
 - (a) Oil all moving parts.
 - (b) With lifting frame (1) at lowest point check hydraulic oil level by removing filler plug (2). Oil should be at bottom of filler hole. Top up, or allow to drain, as necessary and replace plug.
- 3.2. Lifting - centre the trolley around the wheel, as close in as possible, and raise the lifting frame by operating the foot pedal (3).
- 3.3. Lowering - turn valve (4) anticlockwise, against spring load, for controlled lowering of the lifting frame.
- 3.4. Movement - before moving the laden trolley ensure that the wheel is centred on the rollers and restrained by the chain (5) and that the lifting frame is as low as possible whilst allowing clearance between tyre and floor.

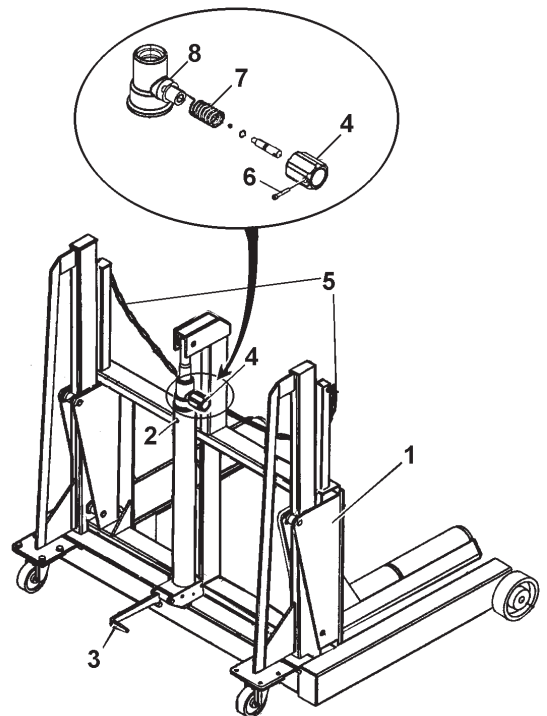

4. MAINTENANCE

- 4.1. Daily Check for damage and oil leaks.
- 4.2. Monthly Oil moving parts and grease pedal-to-piston faces. Check for abnormal wear and tear. With lifting frame (1) at lowest point, check hydraulic oil level by removing filler plug (2). Level should be at bottom of filler hole. Top up, or allow to drain, as necessary. Replace plug.

5. FAULTS

- 5.1. Lifting frame does not reach full height - low oil level, check and fill (see 4.2.).
- 5.2. Foot pump ineffective - oil level too high, check and drain (see 4.2.).
- 5.3. Lifting frame drops - reset release valve spring as follows:
Turn release valve handle (4) fully clockwise. Remove handle locating screw (6) and pull handle (4) from valve spindle. Ensure that spring (7) tang is engaged with valve cylinder nut (8). Align screw hole in handle with hole in spindle and, with spring tang engaged in appropriate hole inside handle, push handle onto spindle. Rotate handle (4) 1/2 turn anticlockwise, to tension spring, and refit locating screw (6).

NOTE: It is our policy to continually improve products and as such we reserve the right to alter data, specifications and component parts without prior notice.

IMPORTANT: No liability is accepted for incorrect use of this product.

WARRANTY: Guarantee is 12 months from purchase date, proof of which will be required for any claim.

INFORMATION: For a copy of our latest catalogue and promotions call us on 01284 757525 and leave your full name and address, including postcode.

