



# TIMING TOOL SET FOR HYUNDAI 1.6D BELT DRIVE

MODEL NO: **VSE5939**

Thank you for purchasing a Sealey product. Manufactured to a high standard, this product will, if used according to these instructions, and properly maintained, give you years of trouble free performance.

**IMPORTANT:** PLEASE READ THESE INSTRUCTIONS CAREFULLY. NOTE THE SAFE OPERATIONAL REQUIREMENTS, WARNINGS & CAUTIONS. USE THE PRODUCT CORRECTLY AND WITH CARE FOR THE PURPOSE FOR WHICH IT IS INTENDED. FAILURE TO DO SO MAY CAUSE DAMAGE AND/OR PERSONAL INJURY AND WILL INVALIDATE THE WARRANTY. KEEP THESE INSTRUCTIONS SAFE FOR FUTURE USE.



Refer to instructions



Wear eye protection



Wear protective gloves



Wear safety footwear



Wear protective clothing

## 1. SAFETY

**IMPORTANT!** These instructions are provided as a guide only. Always refer to the vehicle manufacturer's service instructions or a proprietary manual to establish the correct procedure and data.

- ❑ **WARNING!** Wear approved eye protection. Wear appropriate Personal Protective Equipment. A full range of Personal Protective Equipment is available from your Sealey stockist.
- ❑ **WARNING!** Ensure that Health & Safety, Local Authority Regulations and general workshop practice Regulations are adhered to when using tools.
- ❑ **WARNING!** Incorrect or out of phase camshaft timing can result in contact between the valve head and the piston crown. This will cause damage to the engine.
- ❑ **WARNING!** The warnings, cautions and instructions in this manual cannot cover all possible conditions and situations. The Operator / user must apply caution and common sense (good practical sense).
- \* **DO NOT** use tools if damaged.
- \* **DO NOT** attempt to start or move a vehicle whilst in gear and with timing devices fitted.
- ✓ Wear suitable clothing to avoid snagging. **DO NOT** wear jewellery. Tie back long hair.
- ✓ Ensure that a vehicle that has been raised by a jack is adequately supported. Use axle stands.
- ✓ When timing an engine, always prevent the engine from being turned over. Use a notice and / or inhibit the engine.
- ✓ Keep children and unauthorised persons away from the work area.
- ✓ Maintain tools to ensure that they are in an adequate condition for safe use and optimum performance.
- ✓ Account for all tools, parts and components being used. **DO NOT** leave these in or near the engine.
- ✓ Return tools to suitable storage after use.
- ✓ When not in use, store in a safe, dry childproof place.

## 2. INTRODUCTION

Suitable for 1.6CRDi belt drive diesel engines. Contains the essential tools required during timing belt replacement and timing checks.

## 3. CONTENTS

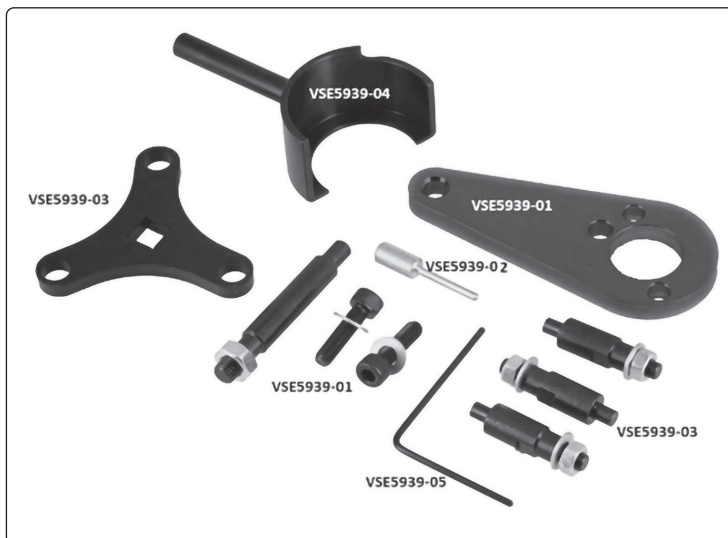

PART NUMBER	DESCRIPTION	OEM NUMBER
VSE5939-01	Crankshaft Locking Tool	09240-2U100
VSE5939-02	Camshaft Locking Tool	09240-2U300
VSE5939-03	Camshaft Sprocket Holding Tool	09240-2U400
VSE5939-04	Tensioner Pulley Holding Tool	09240-2U500
VSE5939-05	Tensioner Locking Pin	N/A

## 4. APPLICATIONS

### MODELS:

#### HYUNDAI

i30 (20-22)  
i40 (18 - 20)  
Kona (20-22)  
Tucson (20-22)  
i40 (18-20)

#### KIA

Ceed (20-22)  
ProCeed (20-22)  
XCeed (20-22)

**ENGINE CODES:** 1.6CRDi - D4FE, D4FEU3

## 5. INSTRUCTIONS

### 5.1. REMOVAL

- 5.1.1. Rotate the crankshaft clockwise to TDC on cylinder number one.
- 5.1.2. Ensure the crankshaft pulley timing marks are aligned (fig.1)
- 5.1.3. Remove the starter motor and fit the VSE5935 Flywheel Locking Tool. (not supplied)
- 5.1.4. Remove the crankshaft pulley bolts and crankshaft pulley.
- 5.1.5. Remove the timing belt lower cover, ensure the crankshaft sprocket timing mark is aligned with the timing mark on the cylinder block. (fig.2)
- 5.1.6. Fit the VSE5939-01 Crankshaft Locking Tool using the hex bolts supplied. (fig.2)
- 5.1.7. Slacken the tensioner pulley securing bolt.
- 5.1.8. Fit the VSE5939-03 Camshaft Sprocket Holding Tool.
- 5.1.9. Use a suitable ½" drive wrench with the camshaft sprocket holding tool as a counter hold and slacken the camshaft sprocket bolts.

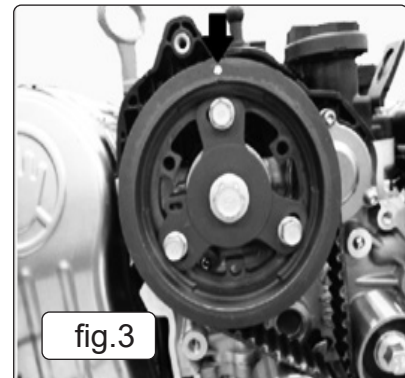
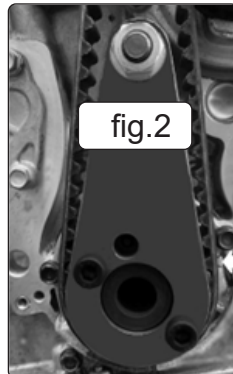
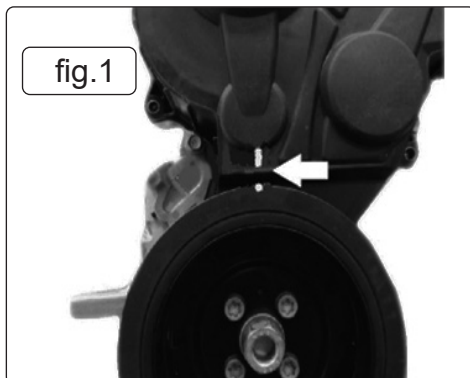

- 5.1.10. Rotate the camshaft sprocket until the sprocket timing marks are aligned with the timing marks on the cylinder head. (fig.3)
- 5.1.11. Fit the VSE5939-04 Tensioner Pulley Holding Tool and turn the tensioner pulley anti-clockwise and lock into place with the VSE5939-05 Tensioner Locking Pin.
- 5.1.12. Remove the Tensioner Pulley Holding Tool.
- 5.1.13. Remove the timing belt.

### 5.2.

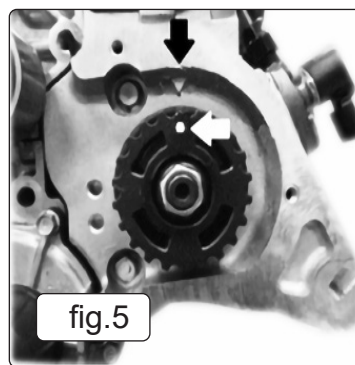
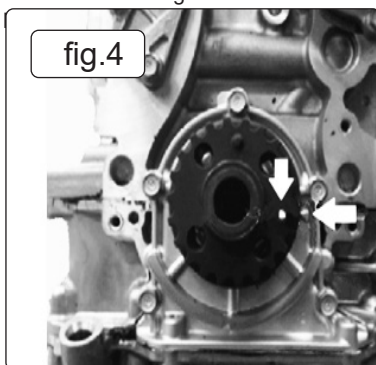

- 5.2.1. Fit new guide pulley and guide pulley bolt, tighten to 42-54 Nm.
- 5.2.2. Fit new tensioner pulley and pulley bolt, at this stage just finger tighten the bolt. Lock the tensioner into its retracted position with the VSE5939-05 Tensioner Locking Pin.
- 5.2.3. Ensure the camshaft, (fig.3) crankshaft, (fig.4) and high pressure fuel pump (fig.5) timing marks are aligned correctly.
- 5.2.4. Fit the timing belt and ensure the timing marks on the belt are aligned with the timing marks on the sprockets.
- 5.2.5. Remove the VSE5939-05 Tensioner Locking Pin.

- 5.2.6. Using the VSE5939-03 Camshaft Sprocket Holding Tool, apply an anti-clockwise torque of 34-44 Nm to the camshaft sprocket.
- 5.2.7. Tighten the camshaft sprocket bolts to 20-25 Nm.
- 5.2.8. Remove the Camshaft Sprocket Holding Tool.
- 5.2.9. Turn the belt tensioner pulley slowly clockwise until the pointer is aligned with the notch.
- 5.2.10. Tighten the tensioner pulley bolt to 25-34 Nm.
- 5.2.11. Remove the VSE5939-02 Camshaft Locking Tool.
- 5.2.12. Ensure the crankshaft high pressure fuel pump, and camshaft sprocket timing marks are aligned.
- 5.2.13. Remove the VSE5939-01 Crankshaft Locking Tool.
- 5.2.14. Rotate the crankshaft through two revolutions clockwise, ensure the belt tensioner pointer is aligned with the notch.
- 5.2.15. Ensure the VSE5939-02 Camshaft Locking Tool can be inserted easily. If it cannot be inserted easily the timing procedure will need to be repeated.
- 5.2.16. Tighten the crankshaft pulley bolts to 33-37 Nm.
- 5.2.17. Reassemble in the reverse order of dismantling.



#### ENVIRONMENT PROTECTION

Recycle unwanted materials instead of disposing of them as waste. All tools, accessories and packaging should be sorted, taken to a recycling centre and disposed of in a manner which is compatible with the environment. When the product becomes completely unserviceable and requires disposal, drain any fluids (if applicable) into approved containers and dispose of the product and fluids according to local regulations.

**Note:** It is our policy to continually improve products and as such we reserve the right to alter data, specifications and component parts without prior notice.

**Important:** No Liability is accepted for incorrect use of this product.

**Warranty:** Guarantee is 12 months from purchase date, proof of which is required for any claim.



REGISTER YOUR PURCHASE HERE

Sealey Group, Kempson Way, Suffolk Business Park, Bury St Edmunds, Suffolk. IP32 7AR



01284 757500



01284 703534



sales@sealey.co.uk



www.sealey.co.uk