

# DIESEL LOCKING KIT- RENAULT/NISSAN DCi VAUXHALL/OPEL Di/DTi/CDTi

MODEL No: **VSE5871**

Thank you for purchasing a Sealey product. Manufactured to a high standard this product will, if used according to these instructions and properly maintained, give you years of trouble free performance.



**IMPORTANT: PLEASE READ THESE INSTRUCTIONS CAREFULLY. NOTE THE SAFE OPERATIONAL REQUIREMENTS, WARNINGS AND CAUTIONS. USE THE PRODUCT CORRECTLY AND WITH CARE FOR THE PURPOSE FOR WHICH IT IS INTENDED. FAILURE TO DO SO MAY CAUSE DAMAGE AND/OR PERSONAL INJURY AND WILL INVALIDATE THE WARRANTY. PLEASE KEEP INSTRUCTIONS SAFE FOR FUTURE USE.**

## 1. SAFETY INSTRUCTIONS

- WARNING!** Ensure Health and Safety, local authority and general workshop practice regulations are adhered to when using tools.
- DO NOT** use tools if damaged.
- ✓ Maintain tools in good and clean condition for best and safest performance.
- ✓ Ensure that a vehicle which has been jacked up is adequately supported with axle stands.
- ✓ Wear approved eye protection. A full range of personal safety equipment is available from your Sealey dealer.
- ✓ Wear suitable clothing to avoid snagging. **DO NOT** wear jewellery and tie back long hair.
- DO NOT** attempt to start engine or move vehicle whilst in gear with timing devices fitted.
- ✓ Always display warning notification on steering wheel when timing engine components.
- ✓ Account for all tools, locking bolts, pins and parts being used and do not leave them in or near the engine.
- WARNING!** Incorrect camshaft timing can result in contact between valve head and piston crown causing damage to the engine.
- ▲ **IMPORTANT:** Always refer to the vehicle manufacturer's service instructions, or a proprietary manual, to establish the current procedure and data.



## 2. INTRODUCTION

Essential tools for timing belt replacement on a wide range of Renault, Nissan & Vauxhall/Opel diesel engines. Supplied in storage case.

Item	Description	OEM Number
1	Inlet Camshaft Locking Tool	KM6205 / MOT1534
2	Exhaust Camshaft Locking Tool	KM6204 / MOT1537
3	Pump Locking Pin	MOT1538
4	Tensioner Tool Set (5 parts)	MOT1543
5	Timing Pin	MOT1430
6	Crankshaft Timing Pin	MOT1536
7	Crankshaft Timing Pin	MOT1489
8	M6 Bolt	

## 3. APPLICATIONS

RENAULT	NISSAN	ENGINE CODES
Avantime (05 - 07)	Almera N16 (02 - 06)	1.5 - K9K
Clio II (01 - 06)	Interstar (02 - 06)	1.9 - F9Q
Clio III (05 - 08)	Kubistar (03 - 08)	2.2 - G9T
Espace (00 - 08)	Micra K12 (03 - 08)	2.5 - G9U
Kangoo (00 - 08)	Note (06 - 08)	
Laguna (99 - 01)	Primastar (02 - 07)	
Laguna II (04 - 07)	Primera P12 (03 - 07)	
Master (00 - 06)	Qashqai (08 - 09)	
Megane (99 - 03)		
Megane II (02 - 08)	<b>VAUXHALL / OPEL</b>	
Modus (04 - 08)	Movano (00 - 08)	
Scenic (99 - 03)	Vivaro (01 - 08)	
Scenic II (03 - 08)		
Trafic (01 - 08)		
Twingo (07 - 08)		

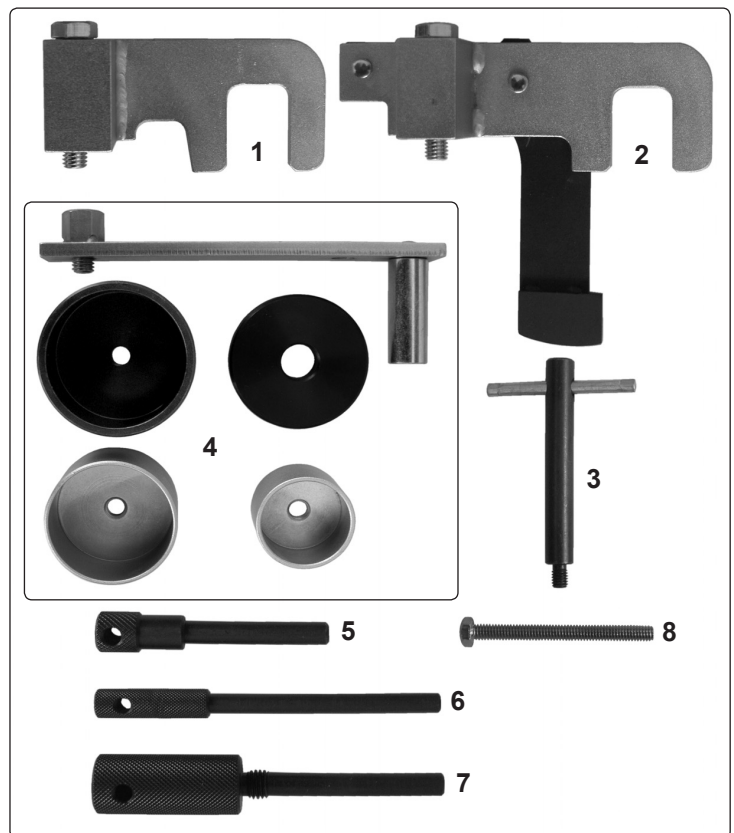

**NOTE:** It is our policy to continually improve products and as such we reserve the right to alter data, specifications and component parts without prior notice.

**IMPORTANT:** No liability is accepted for incorrect use of this product.

**WARRANTY:** Guarantee is 12 months from purchase date, proof of which will be required for any claim.

**INFORMATION:** For a copy of our latest catalogue and promotions call us on 01284 757525 and leave your full name and address, including postcode.

