



# FUEL PUMP HOLDING TOOL - JAGUAR, LAND ROVER 3.0D - BELT DRIVE

MODEL NO: **VSE5312.V2**

Thank you for purchasing a Sealey product. Manufactured to a high standard, this product will, if used according to these instructions, and properly maintained, give you years of trouble free performance.

**IMPORTANT:** PLEASE READ THESE INSTRUCTIONS CAREFULLY. NOTE THE SAFE OPERATIONAL REQUIREMENTS, WARNINGS & CAUTIONS. USE THE PRODUCT CORRECTLY AND WITH CARE FOR THE PURPOSE FOR WHICH IT IS INTENDED. FAILURE TO DO SO MAY CAUSE DAMAGE AND/OR PERSONAL INJURY AND WILL INVALIDATE THE WARRANTY. KEEP THESE INSTRUCTIONS SAFE FOR FUTURE USE.



Refer to  
Instructions



Wear eye  
Protection

## 1. SAFETY

- WARNING!** Wear approved eye protection. Wear appropriate Personal Protective Equipment. A full range of Personal Protective Equipment is available from your Sealey stockist.
- WARNING!** Ensure that Health & Safety, Local Authority Regulations and general workshop practice Regulations are adhered to when using tools.
- × **DO NOT** use tools if damaged.
- ✓ Maintain tools to ensure that they are in an adequate condition for safe use and optimum performance.
- ✓ Ensure that a vehicle that has been raised by a jack is adequately supported. Use axle stands.
- ✓ Wear suitable clothing to avoid snagging. **DO NOT** wear jewellery. Tie back long hair.
- ✓ Account for all tools, parts and components being used. **DO NOT** leave these in or near the engine. Return tools to suitable storage after use.
- ▲ **IMPORTANT!** These Instructions are provided as a guide only. Always refer to the vehicle manufacturer's service instructions or a proprietary manual to establish the correct procedure and data.
- WARNING!** The warnings, cautions and instructions in this manual cannot cover all possible conditions and situations. The Operator / user must apply caution and common sense (good practical sense).
- ✓ When timing an engine, always prevent the engine from being turned over. Use a notice and/or inhibit the engine.
- WARNING!** Incorrect or out of phase camshaft timing can result in contact between the valve head and the piston crown. This will cause damage to the engine.

## 2. INTRODUCTION

Used to position and lock the high pressure fuel pump into its timed position when changing the fuel pump drive belt.

## 3. APPLICATIONS

### MODELS:

**Jaguar:** XF (09-18), XJ (09-14), F-Pace (16-18)  
**Land Rover:** Discovery 3 (04-09), Discovery 4 (09-20),  
Range Rover L405 (12-20), Range Rover Sport (09-20),  
Range Rover Velar (17-20)

### ENGINE:

**3.0 TDV6:** 306DT, AJ-V6D/306DT

### OEM TOOLS:

**Jaguar,**

**Land Rover:** 310-212

**ASSOCIATED TOOLS:** VSE5000A - Diesel engine timing tool kit - Land Rover, Jaguar, Citroen, Peugeot 2.7D, 3.0D - Belt Drive



## 4. OPERATION

**NOTE:** The Sealey VSE5312 Fuel Pump Holding Tool should be used in conjunction with the Sealey VSE5000A Setting and Locking Kit.

### 4.1. REMOVAL

- 4.1.1. Remove the rear engine cover and right hand bulkhead cover.
- 4.1.2. Disconnect and seal off the EGR coolant hoses.
- 4.1.3. Remove steering column lower joint bolt and disconnect the steering angle sensor multi-plug.
- 4.1.4. Remove steering rack mounting bolts to gain access to starter motor, remove starter motor.
- 4.1.5. Remove the high-pressure fuel pump belt cover.
- 4.1.6. Turn the crankshaft clockwise until the timing marks are aligned.
- 4.1.7. Fit the appropriate Flywheel Locking Tool from the VSE5000A Setting and locking Kit, and secure it using a starter motor bolt.
- 4.1.8. Remove the high fuel pump tensioner, and tensioner pulley.
- 4.1.9. Remove the high-pressure fuel pump belt.

#### NOTES:

The high-pressure fuel pump rotates in an anti-clockwise direction when viewed from the rear of the engine.

Early engines had timing marks on the high pressure pump drive belt and pulleys which must be aligned, these early variants also have elongated camshaft sprocket bolt holes. On later variants the fuel pump is not timed to the engine and therefore it has no timing marks and does not have adjustable pulleys.

Fig.1 shows the early engine variant with adjustable pulleys and the timing mark locations indicated.

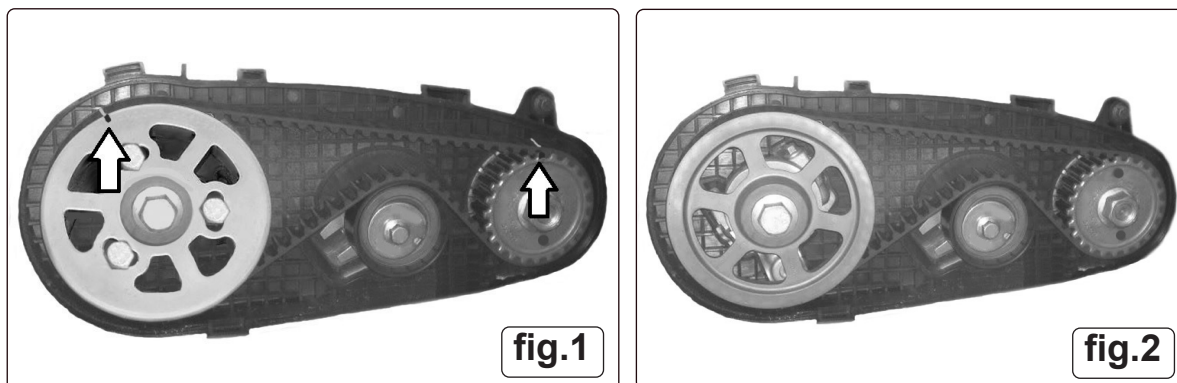

Fig.2 shows the later engine variant with fixed pulleys and no timing marks.

#### 4.2. INSTALLATION

**NOTE: DO NOT** remove the belt tensioner pulley locking pin before fitting tensioner pulley to engine.

4.2.1. Fit the new high-pressure fuel pump belt and the new tensioner pulley, these items should all be fitted together; ensure the timing marks on belt are aligned with the marks on sprockets. (If applicable to the engine variant).

**NOTE:** Ensure lug on rear of the tensioner pulley is located in groove in cylinder head.

4.2.2. Fit the VSE5312 Fuel Pump Sprocket Locking Tool ensuring its location pin is correctly located into the datum point on the engine and the pins are correctly located into the drive sprocket.

4.2.3. Slacken the camshaft rear sprocket securing bolts sufficiently to allow the sprocket to be moved within the slotted holes. (If applicable to the engine variant).

4.2.4. Tighten the tensioner pulley securing bolt to 23 Nm to the specified torque.

4.2.5. Remove the tensioner pulley locking pin, the tensioner is a self-tensioning type.

4.2.6. Tighten the tensioner pulley securing bolt to the specified torque.

4.2.7. Remove the tensioner pulley locking pin, the tensioner is a self-tensioning type.

4.2.8. Tighten the camshaft rear sprocket securing bolt(s) to the specified torque.

4.2.9. Remove the VSE5312 Fuel Pump Sprocket Locking Tool.

4.2.10. Re-fit the high-pressure fuel pump belt cover.

4.2.11. Install the remaining components in the reverse order of removal.



#### ENVIRONMENT PROTECTION

Recycle unwanted materials instead of disposing of them as waste. All tools, accessories and packaging should be sorted, taken to a recycling centre and disposed of in a manner which is compatible with the environment. When the product becomes completely unserviceable and requires disposal, drain any fluids (if applicable) into approved containers and dispose of the product and fluids according to local regulations.

**Note:** It is our policy to continually improve products and as such we reserve the right to alter data, specifications and component parts without prior notice.

**Important:** No Liability is accepted for incorrect use of this product.

**Warranty:** Guarantee is 12 months from purchase date, proof of which is required for any claim.

Sealey Group, Kempson Way, Suffolk Business Park, Bury St Edmunds, Suffolk. IP32 7AR



01284 757500



01284 703534



sales@sealey.co.uk



www.sealey.co.uk