

Thank you for purchasing a Sealey product. Manufactured to a high standard this product will, if used according to these instructions and properly maintained, give you years of trouble free performance.



IMPORTANT: PLEASE READ THESE INSTRUCTIONS CAREFULLY. NOTE THE SAFE OPERATIONAL REQUIREMENTS, WARNINGS AND CAUTIONS. USE THE PRODUCT CORRECTLY AND WITH CARE FOR THE PURPOSE FOR WHICH IT IS INTENDED. FAILURE TO DO SO MAY CAUSE DAMAGE AND/OR PERSONAL INJURY, AND WILL INVALIDATE THE WARRANTY. PLEASE KEEP INSTRUCTIONS SAFE FOR FUTURE USE.

1. SAFETY INSTRUCTIONS

- ❑ **WARNING!** Ensure Health and Safety, local authority and general workshop practice regulations are adhered to when using tools.
- ✗ **DO NOT** use tools if damaged.
- ✓ Maintain tools in good and clean condition for best and safest performance.
- ✓ Ensure that the vehicle which has been jacked up is adequately supported with axle stands.
- ✓ Wear approved eye protection. A full range of personal safety equipment is available from your Sealey dealer.
- ✓ Wear suitable clothing to avoid snagging. Do not wear jewellery and tie back long hair.
- ✓ Account for all tools, locking bolts, pins and parts being used and do not leave them in or near the engine.
- ✗ **DO NOT** use an impact wrench with this tool.

IMPORTANT: Refer to the vehicle manufacturer's service instructions, or a proprietary manual, to establish the current procedure and data.

2. INTRODUCTION & APPLICATION

2.1 Introduction: Remove/Install front mounting bushes in Laguna rear sub-frame. Can be used in situ – no need to remove subframe from vehicle.

Applications: Renault Laguna, 2001 onwards.

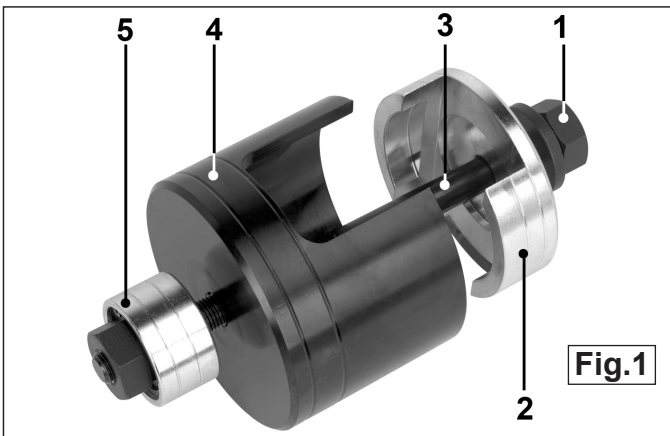

ITEM	PART NO:	DESCRIPTION
1	VSE4777.01	FLANGE NUT
2	VSE4777.02	BRIDGE PIECE
3	VSE4777.03	FORCE SCREW
4	VSE4777.04	COMPRESSOR SLEEVE
5	VSE4777.05	FORCE NUT ASSEMBLY

3. OPERATION

DO NOT USE AN IMPACT WRENCH WITH THIS TOOL.

- 3.1 Ensure that the vehicle is adequately supported on axle stands before working under the vehicle.
- 3.2 Although there is no need to remove the subframe from the

vehicle it will be necessary to lower it to gain access to both sides of the bush housing.

3.3 Remove the rear wheels, the brake pipe retaining plate, the left- and right-hand bush retaining brackets and the lower shock absorber bolts. **For a detailed and up to date breakdown of this procedure refer to the vehicle manufacturer's service instructions, or a proprietary manual.**

3.4 To remove the old bush assemble the tool onto the bush and sub-frame as shown in Fig.2. Ensure that the threaded rod 3 is well lubricated prior to assembly. Hold the flange nut 1 with a 24mm ring spanner. Using a ratchet wrench with a 24mm deep socket turn the nut on the force nut assembly 5 clockwise to drive the bush out of its housing. The bush will come out more easily if penetrating oil has been applied to the bush housing prior to removal.

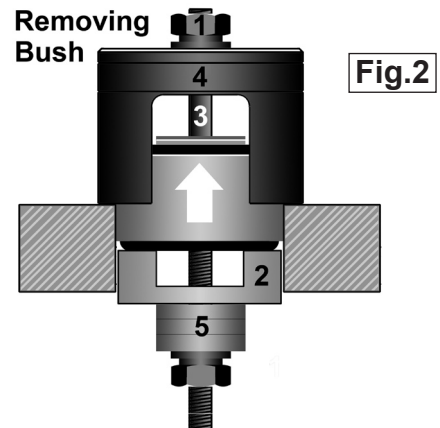

3.5 To insert the new bush, assemble the tool and bush onto the sub-frame as shown in Fig.3. Ensure that the threaded rod 3 is well lubricated prior to assembly. Hold the hex nut 1 with a 24mm ring spanner. Using a ratchet wrench with a 24mm deep socket turn the nut on the force nut assembly 5 clockwise to drive the bush into the compression sleeve 4.

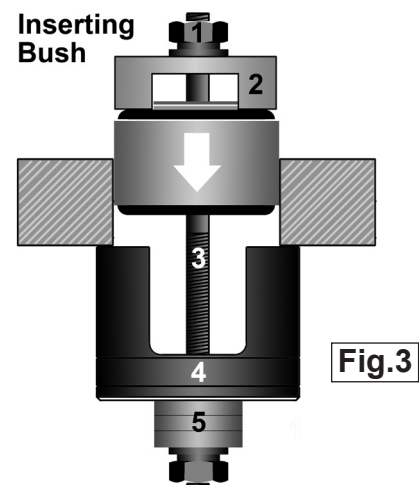

**ALWAYS KEEP THREADED ROD
WELL LUBRICATED.**



DO NOT USE AIR TOOLS.

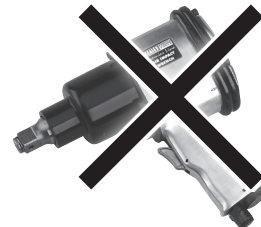

Threaded rod maximum load 150Nm. Exceeding this load will shorten the life of the threaded rod. The threaded rod is considered to be a consumable item and is NOT covered under warranty.

NOTE: It is our policy to continually improve products and as such we reserve the right to alter data, specifications and component parts without prior notice. **IMPORTANT:** No liability is accepted for incorrect use of product. **WARRANTY:** Guarantee is 12 months from purchase date, proof of which will be required for any claim. **INFORMATION:** For a copy of our latest catalogue and promotions call us on 01284 757525 and leave your full name and address, including postcode.



Sole UK Distributor
Sealey Group,
Bury St. Edmunds, Suffolk.

 01284 757500
 01284 703534

 www.sealey.co.uk
 sales@sealey.co.uk