

## PETROL ENGINE SETTING/LOCKING TOOL KIT - BMW M52/M54/M56

### 1. SAFETY INSTRUCTIONS

- WARNING!** *Ensure Health and Safety, local authority and general workshop practice regulations are adhered to when using tools.*
- DO NOT** use if damaged.
- Maintain in good and clean condition for best and safest performance.
- Wear approved eye protection. A full range of personal safety equipment is available from your Sealey dealer.
- Wear suitable clothing to avoid snagging. Do not wear jewellery and tie back long hair.
- Account for all tools, locking bolts, pins and parts being used and do not leave them in or near the engine.
- WARNING!** Incorrect or out of phase camshaft timing can result in contact between the valve head and the piston crown causing damage to the engine.

**IMPORTANT:** *Always refer to the vehicle manufacturer's service instructions, or a proprietary manual, to establish the current procedure and data.*

- WARNING!** *The warnings, cautions and instructions discussed in this manual cannot cover all possible conditions and situations that may occur. It must be understood that common sense and caution are factors which cannot be built into this product, but must be applied by the operator.*

### 2. INTRODUCTION & APPLICATION

#### 2.1. Introduction

Suitable for setting and locking camshafts on chain-driven BMW Vanos engines.

Set includes set-up bracket, chain tensioner locking pin, secondary sprocket tool and primary chain tensioner tool.

Application: BMW 528i, X5, E46, Z3, Z4, 325, 525, M52, M54 and M56 engines.

Item:	Part No:	Description:
1	VSE134.V2-01	ALUMINIUM PLATE
2	VSE134.V2-02	TENSIONER LOCKING PIN
3	VSE134.V2-03	PLATE LOCKING BLOCK
4	VSE134.V2-04	TENSIONER TOOL
5	VSE134.V2-05	AIR CONNECTION TOOL
6	VSE134.V2-06	CASE

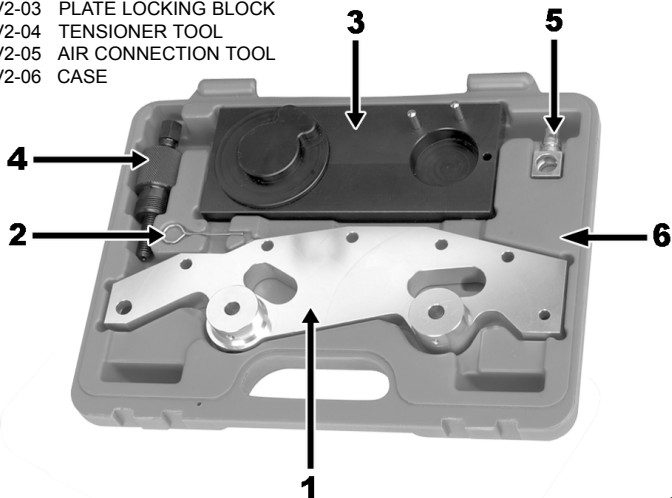



**NOTE:** It is our policy to continually improve products and as such we reserve the right to alter data, specifications and component parts without prior notice.

**IMPORTANT:** No liability is accepted for incorrect use of product.

**WARRANTY:** Guarantee is 12 months from purchase date, proof of which will be required for any claim.

**INFORMATION:** For a copy of our latest catalogue and promotions call us on 01284 757525 and leave your full name and address, including postcode.