

Thank you for purchasing a Sealey product. Manufactured to a high standard this product will, if used according to these instructions and properly maintained, give you years of trouble free performance.



IMPORTANT: PLEASE READ THESE INSTRUCTIONS CAREFULLY. NOTE THE SAFE OPERATIONAL REQUIREMENTS, WARNINGS AND CAUTIONS. USE THIS PRODUCT CORRECTLY AND WITH CARE FOR THE PURPOSE FOR WHICH IT IS INTENDED. FAILURE TO DO SO MAY CAUSE DAMAGE AND/OR PERSONAL INJURY AND WILL INVALIDATE THE WARRANTY.

1. SAFETY INSTRUCTIONS

1.1. ELECTRICAL SAFETY.

☐ **WARNING!** It is the responsibility of the owner and the operator to read, understand and comply with the following:

You must check all electrical products before use to ensure that they are safe. You must inspect power cables, plugs, sockets and any other connectors for wear or damage. You must ensure that the risk of electric shock is minimised by the installation of appropriate safety devices. A Residual Current Circuit Breaker (RCCB) should be incorporated in the main distribution board. We also recommend that a Residual Current Device (RCD) is used. It is particularly important to use an RCD with portable products that are plugged into a supply which is not protected by an RCCB. If in any doubt consult a qualified electrician. You may obtain a Residual Current Device by contacting your Sealey dealer.

You must also read and understand the following instructions concerning electrical safety.

- 1.1.1. The **Electricity at Work Act 1989** requires that all portable electrical appliances, if used on business premises, are tested by a qualified electrician, using a Portable Appliance Tester (PAT), at least once a year.
- 1.1.2. The **Health & Safety at Work Act 1974** makes owners of electrical appliances responsible for the safe condition of those appliances and the safety of the appliance operators. **If in any doubt about electrical safety, contact a qualified electrician.**
- 1.1.3. Ensure that the insulation on all cables and on the appliance is safe before connecting it to the power supply. See 1.1.1. and 1.1.2. and use a Portable Appliance Tester.
- 1.1.4. Ensure that cables are always protected against short circuit and overload.
- 1.1.5. Regularly inspect power supply cables and plugs for wear or damage and check all connections to ensure that none is loose.
- 1.1.6. **Important:** Ensure that the voltage marked on the appliance matches the power supply to be used and that the plug is fitted with the correct fuse - see fuse rating in diagram at the right.
- 1.1.7. **DO NOT** pull or carry the appliance by the power cable.
- 1.1.8. **DO NOT** pull the plug from the socket by the cable.
- 1.1.9. **DO NOT** use worn or damaged cables, plugs or connectors. Immediately have any faulty item repaired or replaced by a qualified electrician. When a BS 1363/A UK 3 pin plug is damaged, cut the cable just above the plug and **dispose of the plug safely.** Fit a new plug according to the following instructions (UK only).
 - a) **Connect the GREEN/YELLOW earth wire to the earth terminal 'E'.**
 - b) **Connect the BROWN live wire to the live terminal 'L'.**
 - c) **Connect the BLUE neutral wire to the neutral terminal 'N'.**
 - d) **After wiring: check that there are no bare wires, that all wires have been correctly connected, that the cable outer insulation extends beyond the cable restraint and that the restraint is tight.**

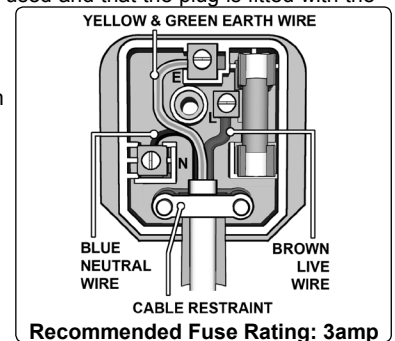

Double insulated products, which are always marked with this symbol,  are fitted with live (brown)

and neutral (blue) wires only. To rewire, connect the wires as indicated above - **DO NOT** connect either wire to the earth terminal.

- 1.1.10. Products which require more than 13 amps are supplied without a plug. In this case you must contact a qualified electrician to ensure that a suitably rated supply is available. We recommend that you discuss the installation of an industrial round pin plug and socket with your electrician.
- 1.1.11. If an extension reel is used it should be fully unwound before connection. A reel with an RCD fitted is preferred since any appliance plugged into it will be protected. The cable core section is important and should be at least 1.5mm², but to be absolutely sure that the capacity of the reel is suitable for this product and for others which may be used in the other output sockets, we recommend the use of 2.5mm² section cable.

IMPORTANT: These instructions are provided as a guide only. Always refer to the vehicle manufacturer's service instructions, or a proprietary manual, to establish the current procedure and data.

WARNING: The warnings, cautions and instructions in this manual cannot cover all possible conditions and situations that may occur. It must be understood that common sense and caution are factors which cannot be built into this product, but must be applied by the operator.

1.2 GENERAL SAFETY

- ☐ **WARNING!** Ensure Health and Safety, local authority and general workshop practice regulations are adhered to when using tools.
- × **DO NOT** use tools if damaged.
- ✓ Maintain tools in good and clean condition for best and safest performance.
- ✓ Ensure that a vehicle which has been jacked up is adequately supported with axle stands.
- ✓ Ensure that all tools are removed from the engine bay upon completion of the job.
- ✓ Wear approved eye protection. A full range of personal safety equipment is available from your Sealey dealer.
- ✓ Wear suitable clothing to avoid snagging. **DO NOT** wear jewellery and tie back long hair.
- ✓ Keep children and unauthorised persons away from the work area.
- × **DO NOT** attempt to start engine or move vehicle whilst in gear.

2. INTRODUCTION AND SPECIFICATIONS

- Allows the Exhaust Gas Recirculation (EGR) valve to be operated in situ.
- Can be held in the open position to aid cleaning of carbon deposits or switched open/closed to check operation.
- Supplied with a range of connectors to suit a range of valves.

SPECIFICATION:

Supply:230V
 Temperature Range:.....-20°C to +60°C
 Continuous Open/Close Cycle Time:90 seconds
 Dimensions:..... 140mm L x 45mm W x 30mm D
 Weight: 200g

3. INSTRUCTIONS

3.1 Preparation

- 3.1.1. **Fig.1:** Remove multi-pin plug (1) from EGR valve body (2).
- 3.1.2. **Fig.2:** Select appropriate lead for vehicle being worked on (see workshop manual/data book for details). Multi-pin, 1.2mm and 2.8mm connections are included.
- 3.1.3. Connect lead to EGR valve socket. Black lead = negative, black and white lead = positive.
- 3.1.4. Connect lead to socket from tester.
- 3.1.5. Connect tester to mains power supply: insert 2 pin plug into base of transformer unit and connect 3 pin plug to 230V socket (UK only). Also supplied with a 2pin EU plug.

3.2 Short Test

- 3.2.1. **Fig.3:** Press the test button for less than 1 second. This will either open or close the valve, depending on initial position.
- 3.2.2. Each subsequent short press of the test button will open or close the valve, establishing if the valve is obeying commands from the engine control unit correctly.
- 3.2.3. A single click from the EGR valve will be heard each cycle.
- 3.2.4. If the valve has been removed from the vehicle, carbon can be removed manually with the valve held open.

3.3 Self-cleaning cycle

- 3.3.1. Press the test button for more than 1 second. This will initiate a continuous test cycle lasting 90 seconds, during which time the valve will repeatedly open and close. This will free accumulated carbon deposits from the valve and seat.
- 3.3.2. A continuous clicking sound will be heard from the valve.
- 3.3.3. During the test the indicator light will flash red.
- 3.3.4. At the end of 90 Seconds, a steady green light will show for 3 seconds. When this goes out, the cleaning cycle is complete.

3.4 Fault indication

- 3.4.1. If the unit is connected to the mains without the test leads connected an alarm will sound continuously indicating the presence of an open circuit.
- 3.4.2. Similarly, if the tester is connected to a faulty EGR valve the alarm will sound. This indicates that the valve unit needs replacement.

3.5 Disconnection

- 3.5.1. When test is completed, disconnect tester from mains socket.
- 3.5.2. Disconnect test lead from EGR valve.
- 3.5.3. Reconnect multi-pin plug from engine control unit to EGR valve socket.
- 3.5.4. Remove all tools from engine bay before starting engine.

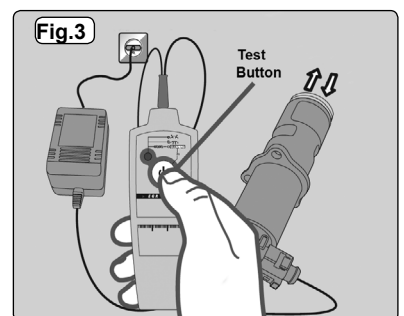
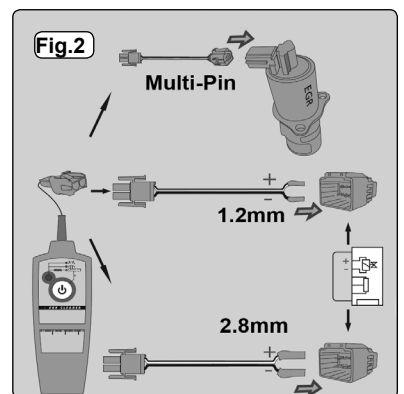
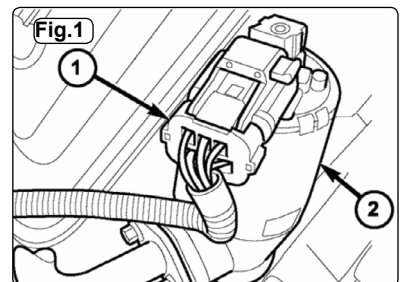

Environmental Protection.



Recycle unwanted materials instead of disposing of them as waste. All tools, accessories and packaging should be sorted, taken to a recycle centre and disposed of in a manner which is compatible with the environment.



When the product is no longer required, it must be disposed of in an environmentally protective way. Contact your local solid waste authority for recycling information.

NOTE: It is our policy to continually improve products and as such we reserve the right to alter data, specifications and component parts without prior notice.

IMPORTANT: No liability is accepted for incorrect use of this product.

WARRANTY: Guarantee is 12 months from purchase date, proof of which will be required for any claim.

INFORMATION: For a copy of our latest catalogue and promotions call us on 01284 757525 and leave your full name and address, including postcode.



Sole UK Distributor, Sealey Group,
 Kempson Way, Suffolk Business
 Park, Bury St. Edmunds, Suffolk,
 IP32 7AR

01284 757500

01284 703534



www.sealey.co.uk



sales@sealey.co.uk

