



MOTORCYCLE CHAIN BREAKER & RIVETER

MODEL NO: VS779.V5

Thank you for purchasing a Sealey product. Manufactured to a high standard, this product will, if used according to these instructions, and properly maintained, give you years of trouble free performance.

IMPORTANT: PLEASE READ THESE INSTRUCTIONS CAREFULLY. NOTE THE SAFE OPERATIONAL REQUIREMENTS, WARNINGS & CAUTIONS. USE THE PRODUCT CORRECTLY AND WITH CARE FOR THE PURPOSE FOR WHICH IT IS INTENDED. FAILURE TO DO SO MAY CAUSE DAMAGE AND/OR PERSONAL INJURY AND WILL INVALIDATE THE WARRANTY. KEEP THESE INSTRUCTIONS SAFE FOR FUTURE USE.



Refer to instructions



Wear protective gloves



Wear safety footwear

1. SAFETY

- ❑ **WARNING!** Ensure Health and Safety, local authority and general workshop practice regulations are adhered to when using tools and equipment.
- ✗ **DO NOT** use if damaged.
- ✓ Maintain in good and clean condition for best and safest performance.
- ✓ Keep the work area clean, uncluttered and ensure there is adequate lighting.
- ✓ Maintain correct balance and footing. Ensure the floor is not slippery and wear non-slip shoes.
- ✓ Keep children and unauthorised persons away from the work area.
- ✗ Ensure that the motorcycle is safely positioned and secured.

2. INTRODUCTION

Breaks and rejoins most types of chain quickly and easily. Suitable for most sizes of drive or cam chain from #25 to #520. Supplied with a range of pins, dies and detailed instructions.

3. CONTENTS

Note: Refer to diagram below for complete list of individual contents. Refer to attached Parts List for Model numbers of parts available as replacements.

Note: Part numbers 18, 6, 17, 16, 15 are fitted into C body 20 on delivery of product.

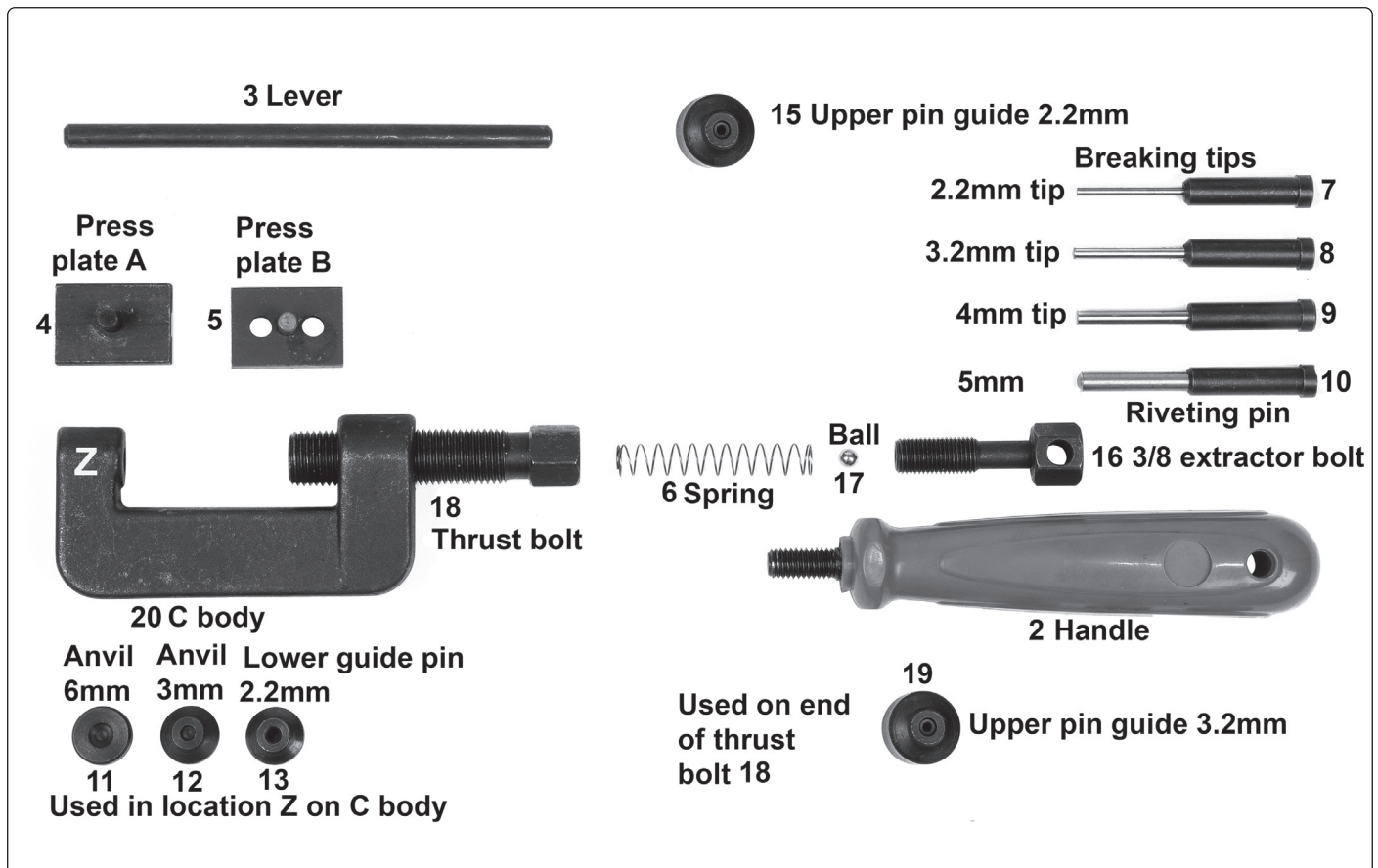

4. OPERATION

4.1. BREAKING CHAIN (pressing out link pin)

NOTE: This tool may be used for breaking all chain sizes from #25 to #520.

If working on cam chain be sure and cover chain tunnel with rag to prevent parts dropping down.

NOTE: The rivet head must be fully ground off first.

- 4.1.1. Select correct size breaking tip for the chain to be worked on, position spring as shown fig.1. (Anvil not used).

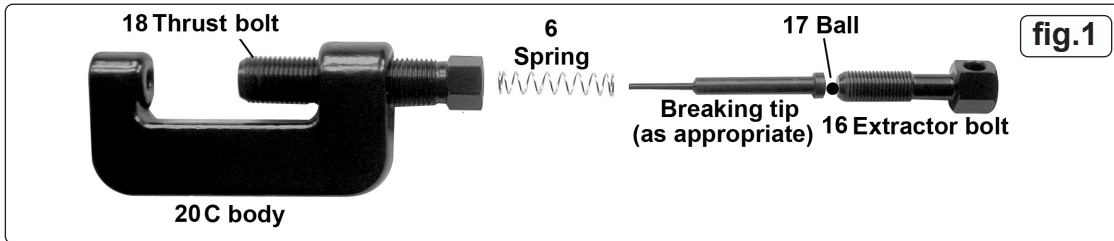

NOTE: If small 2.2 mm breaking tip is used you must also use the anvil (15) on end of thrust bolt (18) and anvil 2.2mm (12) at position Z on the C body (20) (see fig.2) to prevent breaking the tip.

- 4.1.2. The anvil (15) screws onto the alignment bolt (18), the other (12) drops in place in C body (20) at position Z.

NOTE: Smallest breaking tip (2.2 mm) should be used on most cam chain.

3.2 mm breaking tip used on #25 or #35 chain 4.0 and 5.0mm breaking tip for most motorcycle drive chain (428 to 520).

- 4.1.3. Put tool over chain, breaking pin tip must be withdrawn at least 2mm into alignment bolt.

- 4.1.4. The end of the chain rivet should be held in position by the tool alignment bolt, and the tool body. Tighten the alignment bolt securely against chain to hold chain in place.

- 4.1.5. Tighten extractor bolt with wrench or lever bar until the chain pin is pushed out completely.

- 4.1.6. The chain pin will drop out of the hole in the bottom of the tool. (If you don't feel the tip pushing down smoothly, check that the tip is correctly lined up against the link pin. If not realign or you may break the breaking tip.)

- 4.1.7. Withdraw push bolt and breaking tip, loosen alignment bolt and remove.

4.2. INSTALLING CHAIN LINK PIN (riveting)

- 4.2.1. Fit riveting pin (10) into the tool and applicable anvil (11 or 12) into C body (20) at position Z.

- 4.2.2. Assemble the chain with the link to be riveted. New special rivet link pins must be used. The original pin must not be used.

DO NOT use a split pin type connecting link.

- 4.2.3. The pin must be pushed all the way through the chain link.

- 4.2.4. If the pin is hard to insert it can be pushed into place by placing chain into the tool with the riveting pin (10) withdrawn 2mm into the alignment bolt and tightening the alignment bolt until the pin has been pushed through the link.

- 4.2.5. Ensure that an equal length of pin shows on each side of the link

- 4.2.6. Position the tool over the pin to be riveted, make sure riveting pin (10) is withdrawn 2mm into the alignment bolt and tighten the alignment bolt securely against chain.

- 4.2.7. Tighten the push (extractor) bolt so that the riveting pin (10) flares the chain pin.

- 4.2.8. Both ends of the chain link pin should be flared so the pin is securely held in place. Repeat procedure on other link pin.

- 4.2.9. Withdraw the tool, from the chain; visually check that both chain link pins show the same flared ends and that the rivets on the side plates are in alignment with side plates on either side.

NOTE: You may also use the press plates to push the top link plate onto the link pins, as shown in (fig.3).

- 4.2.10. Use the press plate with the two holes (5) in the upper jaw and the grooved press plate (4) in the lower jaw.

- 4.2.11. It is also possible to use a combination of the riveting tip (10) and lower press plate as fig.4.

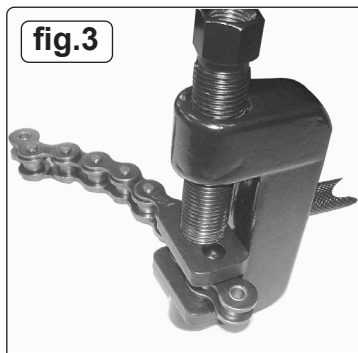

ENVIRONMENT PROTECTION

Recycle unwanted materials instead of disposing of them as waste. All tools, accessories and packaging should be sorted, taken to a recycling centre and disposed of in a manner which is compatible with the environment. When the product becomes completely unserviceable and requires disposal, drain any fluids (if applicable) into approved containers and dispose of the product and fluids according to local regulations.



REGISTER YOUR PURCHASE HERE

Note: It is our policy to continually improve products and as such we reserve the right to alter data, specifications and component parts without prior notice.

Important: No Liability is accepted for incorrect use of this product.

Warranty: Guarantee is 12 months from purchase date, proof of which is required for any claim.

Sealey Group, Kempson Way, Suffolk Business Park, Bury St Edmunds, Suffolk. IP32 7AR



01284 757500



sales@sealey.co.uk



www.sealey.co.uk