

Thank you for purchasing a Sealey product. Manufactured to a high standard, this product will, if used according to these instructions, and properly maintained, give you years of trouble free performance.

IMPORTANT: PLEASE READ THESE INSTRUCTIONS CAREFULLY. NOTE THE SAFE OPERATIONAL REQUIREMENTS, WARNINGS & CAUTIONS. USE THE PRODUCT CORRECTLY AND WITH CARE FOR THE PURPOSE FOR WHICH IT IS INTENDED. FAILURE TO DO SO MAY CAUSE DAMAGE AND/OR PERSONAL INJURY AND WILL INVALIDATE THE WARRANTY. KEEP THESE INSTRUCTIONS SAFE FOR FUTURE USE.



Refer to instruction manual



Wear eye protection

1. SAFETY

- WARNING!** Ensure Health & Safety, local authority, and general workshop practice regulations are adhered to when using this tool.
- WARNING!** Familiarise yourself with the specific applications and limitations of this tool, as well as any potential hazards.
- This tool should be used in conjunction with inspection maintenance procedures recommended in the vehicle manufacturer's manual.
- Ensure that this tool is the correct tool for the task.
- Ensure that the vehicle is properly supported with axle stands before working under the vehicle.
- Ensure that there is adequate lighting prior to using this tool.
- A range of inspection lamps are available from your local Sealey stockist.
- Keep children and unauthorised persons away from the working area.
- Keep the threaded rod well lubricated during operation to ease removal of bushes.
- DO NOT** use this tool for any purpose other than that for which it is designed.
- DO NOT** use air tools with this tool.
- DO NOT** use this tool if any parts are missing or damaged, as this may cause failure and/or personal injury.
- DO NOT** use this tool when you are tired, or under the influence of alcohol, drugs or intoxicating medication.
- When not in use, store in a safe, dry location.

2. INTRODUCTION

Intended for the in-situ removal/installation of Vauxhall/Opel Vectra (95 -02) upper and lower rear trailing arm bushes. Bushes are quickly pressed in or out with tool and a 19mm ratchet wrench (not included).

3. CONTENTS

Item	Part no.	Description
A	VS721.V2-02	Pressed support sleeve 55.5 x 54mm
B	VS721.V2-01	Pressed support sleeve 24.5 x 45mm
C	VS721.V2-03	Pressed support sleeve 20 x 45mm
D & F	VS721.V2-06	Screw nut
E	VS721.02-08	Thick spacer
G	VS721.02-04	Threaded rod

ALWAYS KEEP THREADED ROD WELL LUBRICATED.



DO NOT USE AIR TOOLS.

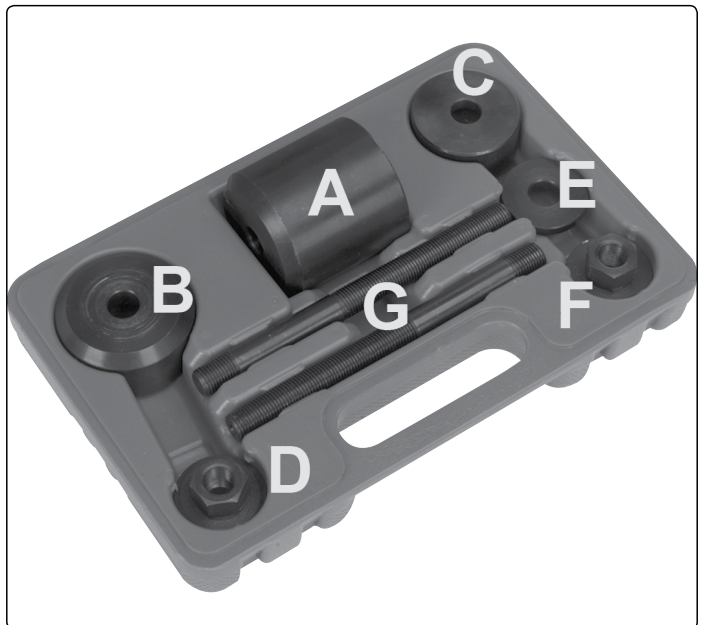
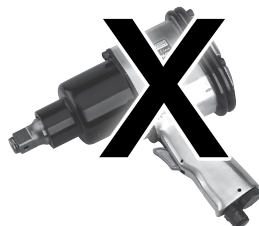

Threaded rod maximum load 150Nm. Exceeding this load will shorten the life of the threaded rod. The threaded rod is considered to be a consumable item and is NOT covered under warranty.

4. OPERATION

fig.1

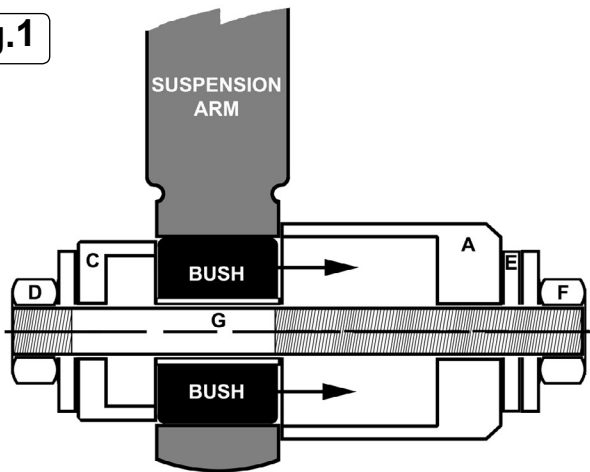

VS721.V2 SET UP TO EXTRACT BUSH

fig.2

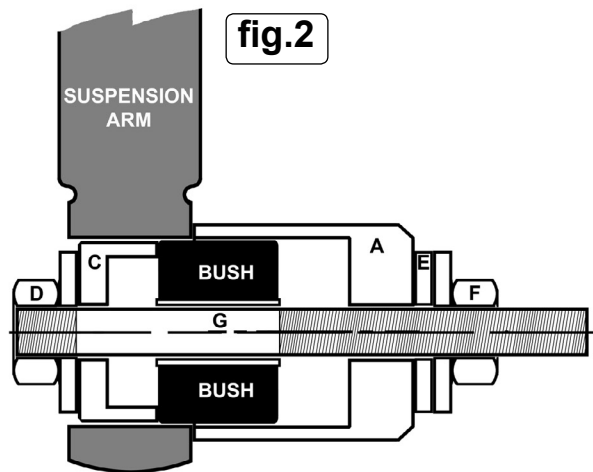

BUSH PARTIALLY EXTRACTED

4.1. REMOVING A BUSH (fig's 1 & 2)

- 4.1.1. Screw the nut with washer attached (D) onto the short threaded portion of threaded rod (G). Slide the pushing cup (C) onto the threaded rod in the orientation shown above in fig.1.
- 4.1.2. Push the threaded rod through the centre of the bush to be removed until the pushing cup bears against the bush.
- 4.1.3. Hold the assembly in place and slide the large static cup (A) onto the rod until it bears against the surface of the suspension arm as shown above in fig.1.
- 4.1.4. Slide washer (E) onto the rod and retain the whole assembly by screwing the nut with washer (F) onto the threaded rod.
- 4.1.5. Hold nut D with a spanner and then place a second spanner over the nut with washer attached (F). This should preferably be a ratchet ring spanner for ease of use and maximum accessibility. As the nut is turned extraction will commence as indicated in fig.2. Some considerable pressure may need to be applied to initiate the first movement of the bush. As the bush leaves the suspension arm ensure that the assembly is supported as it is likely to fall away from the suspension arm once the bush becomes loose.
- 4.1.6. Disassemble the extractor and dispose of the old bush in compliance with local authority waste disposal requirements.

fig.3

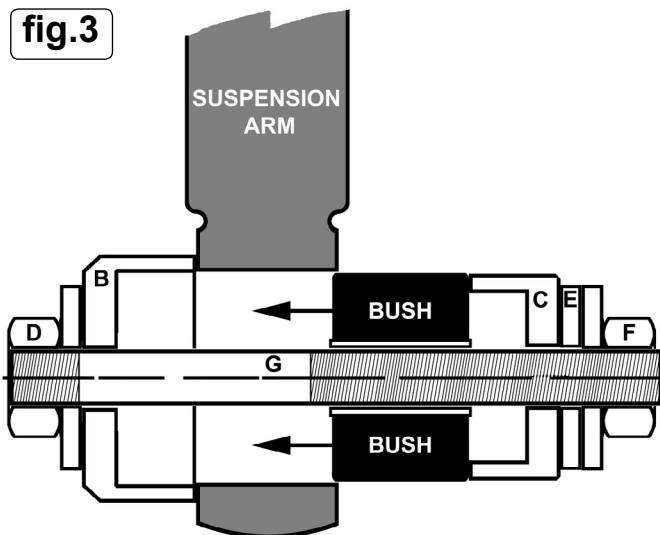

VS721.V2 SET UP TO INSERT BUSH

fig.4

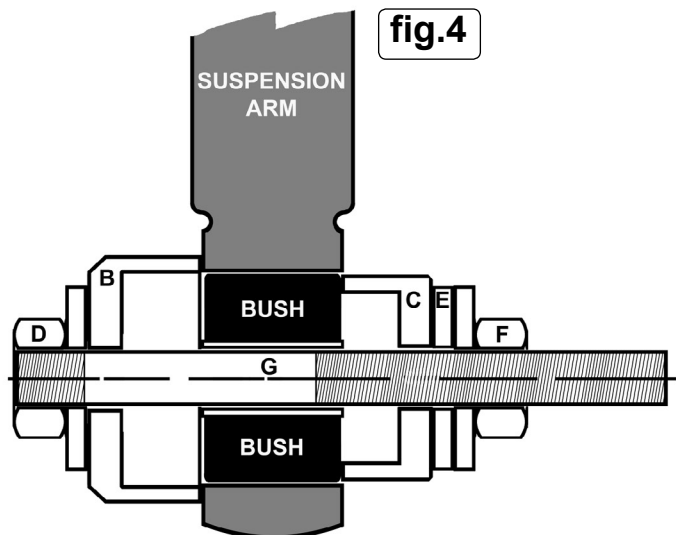

BUSH FULLY INSERTED

4.2. INSERTING A BUSH (fig's 3 & 4)

- 4.2.1. Screw the nut with washer attached (D) onto the short threaded portion of threaded rod (G). Slide the small static cup (B) onto the threaded rod in the orientation shown above in fig.3.
- 4.2.2. Hold the assembly against the suspension arm so that the static cup (B) is aligned with the hole in the arm with the threaded rod sticking through to the other side.
- 4.2.3. Slide the new bush onto the threaded rod and align it with the hole in the arm. Place the pushing cup (C) up against the bush and slide on the washer (E). Retain the whole assembly by screwing on the nut with washer (F). Before commencing insertion ensure that the assembly is aligned with the hole in the suspension arm as shown in fig.3.
- 4.2.4. Hold nut D with a spanner and then place a second spanner over the nut with washer attached (F). This should preferably be a ratchet ring spanner for ease of use and maximum accessibility. As the nut is turned, insertion will commence as indicated in fig.4. Take care not to drive the bush too far into the suspension arm. Cease insertion when the bush is fully inserted into the arm as shown in fig.4.
- 4.2.5. Disassemble the extractor and place the separate components in the case provided.

NOTE: A spare rod (G) is supplied in case of thread damage.



ENVIRONMENT PROTECTION

Recycle unwanted materials instead of disposing of them as waste. All tools, accessories and packaging should be sorted, taken to a recycling centre and disposed of in a manner which is compatible with the environment. When the product becomes completely unserviceable and requires disposal, drain any fluids (if applicable) into approved containers and dispose of the product and fluids according to local regulations.

Note: It is our policy to continually improve products and as such we reserve the right to alter data, specifications and component parts without prior notice.

Important: No Liability is accepted for incorrect use of this product.

Warranty: Guarantee is 12 months from purchase date, proof of which is required for any claim.

Sealey Group, Kempson Way, Suffolk Business Park, Bury St Edmunds, Suffolk. IP32 7AR



01284 757500



01284 703534



sales@sealey.co.uk



www.sealey.co.uk