

Thank you for purchasing a Sealey product. Manufactured to a high standard this product will, if used according to these instructions and properly maintained, give you years of trouble free performance.

**IMPORTANT: PLEASE READ THESE INSTRUCTIONS CAREFULLY. NOTE THE SAFE OPERATIONAL REQUIREMENTS, WARNINGS AND CAUTIONS. USE THE PRODUCT CORRECTLY AND WITH CARE FOR THE PURPOSE FOR WHICH IT IS INTENDED. FAILURE TO DO SO MAY CAUSE DAMAGE AND/OR PERSONAL INJURY AND WILL INVALIDATE THE WARRANTY. PLEASE KEEP INSTRUCTIONS SAFE FOR FUTURE USE.**

**1. SAFETY INSTRUCTIONS**

**WARNING!** Ensure Health and Safety, local authority and general workshop practice regulations are adhered to when using tools.

- X DO NOT** use tools if damaged.
- ✓ Maintain tools in good and clean condition for best and safest performance.
- ✓ Ensure that a vehicle which has been jacked up is adequately supported with axle stands.
- ✓ Wear approved eye protection. A full range of personal safety equipment is available from your Sealey dealer.
- ✓ Wear suitable clothing to avoid snagging. Do not wear jewellery and tie back long hair.
- ✓ Account for all tools, locking bolts, pins and parts being used and do not leave them in or near the engine.

**WARNING!** Incorrect or out of phase camshaft timing can result in contact between valve head and piston crown causing damage to the engine.

**IMPORTANT:** These instructions are provided as a guide only. Always refer to the vehicle manufacturer's service instructions, or a proprietary manual, to establish the current procedure and data. Product Information Sets detail applications and use of the tools, with any general instructions provided as a guide only.



**2. INTRODUCTION & APPLICATIONS**

**2.1 Introduction**

Covers timing belt replacement on the current range of Renault dCi common rail diesel engines. Updated set suitable for Clio 2 1.5dci + 1.9dci 600/800 series engines. These engines are fitted in Renault and Nissan cars and vans, also Vauxhall vans.

**2.2 Applications:**

**RENAULT dCi Common Rail Diesel engines - 1.5, 1.9, 2.2 and 2.5 in:**

**RENAULT**

Clio	Modus	Twingo
Megane / Scenic	Laguna	Espace
Avantime	Kangoo	Trafic
Master		

**VAUXHALL / OPEL**

Vivaro	Movano	
--------	--------	--

**NISSAN**

Micra	Almera	Note
Qashqai	Primera	Kubistar
Primaster	Interstar	

**Engine Codes:**

**K9K, F9Q, G9T & G9U common rail diesel engines.**

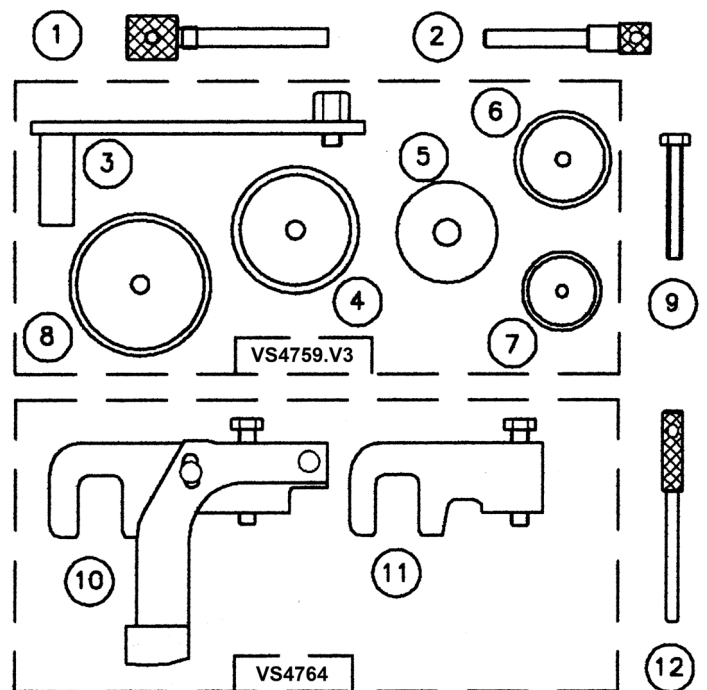

### 3. CONTENTS

1	VS4562A	Crankshaft Locking Pin
2	VS125/R1	Crankshaft & Camshaft Locking Pin
	<b>VS4759.V3</b>	<b>Tensioner Tool (items 3-8)</b>
3	VS4759/1	Arm Assembly
4	VS4759/2	Adaptor
5	VS4759/3	Spacer
6	VS4759/4	Adaptor
7	VS4759/5	Adaptor
8	VS4759/6	Adaptor
9	VS4760/T6	Tensioner Adjusting Bolt
10	VS4764	Camshaft Setting Plate Set
11	VS4763	Crankshaft Locking Pin
--	VS4760.V3/84	Case + Insert

#### VS4760.V3 Diesel Engine Setting / Locking Tool Kit Comprises: Crankshaft / Camshaft Locking Pins –

VS4562A –	Crankshaft (1.5)
VS125/R1	Crankshaft (1.9) & Camshaft (1.5)
VS4763	Crankshaft (2.2 / 2.5)

#### Tensioner Tools –

VS4730/T6	Adjusting Bolt (1.9)
VS4759.V3	Tensioner Tool (1.9)

#### Camshaft Setting Plate Set –

VS4764 Inlet / Exhaust Plates (Pair)	(2.2 / 2.5)
--------------------------------------	-------------

#### 1.5 dCi Engines (K9K)

The K9K series of 1.5dCi engines require Crankshaft Locking Pin VS4562A and Pin VS125/R1 to position the camshaft / sprocket.

As it is necessary to remove the RH engine mounting / bracket when removing and installing the timing belt, the engine must be supported from below.

Remove the upper and lower timing belt covers, fuel pump position sensor and move fuel pipes to one side.

### 4. INSTRUCTIONS

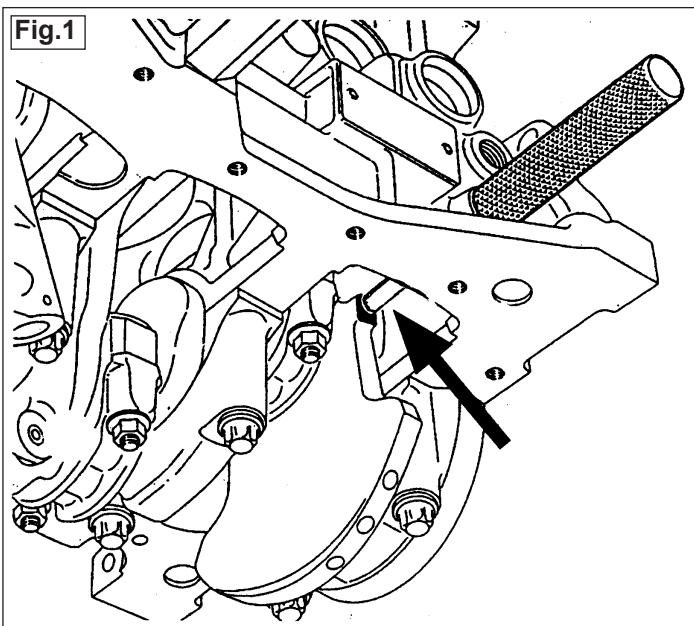

#### 4.1 VS4562A Crankshaft Locking Pin

Remove the blanking plug for the crankshaft locking pin from the cylinder block and turn the crankshaft in a clockwise direction so that the camshaft sprocket locking pin hole is **just before** its alignment position with the

timing hole in the cylinder head. This will provide the correct crankshaft position for inserting the VS4562A Crankshaft Locking Pin.

Screw in VS4562A Locking Pin and turn the crankshaft slightly until the “flat” on web of the crankshaft is pressing against the end of the pin. (Fig.1)

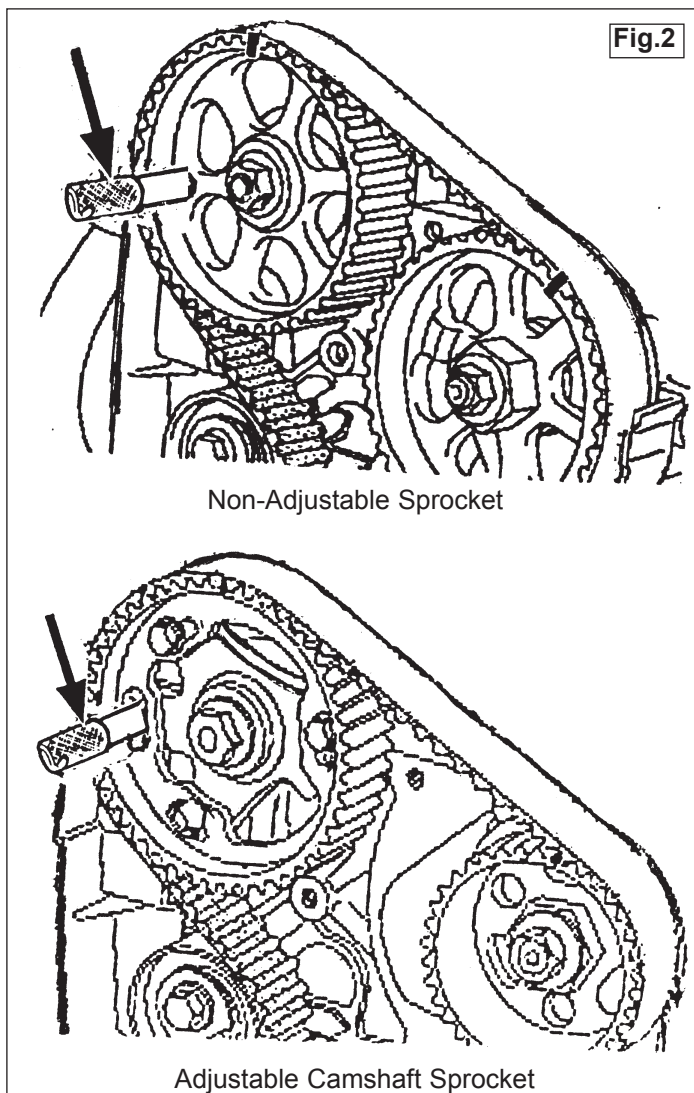

#### 4.2 VS125/R1 Camshaft Locking Pin

Insert VS125/R1 Pin through the timing hole in the camshaft sprocket and into the timing hole in the cylinder head. (Fig.2)

**NOTE:** Some 1.5 K9K engine variants have an adjustable camshaft sprocket (identified by 3 x sprocket retaining bolts to a camshaft carrier plate and elongated timing slot in the sprocket).

**4.2.1** Remove the crankshaft pulley, slacken the belt tensioner and remove belt.

Once a belt has been removed, a new belt and tensioning rollers must be fitted.

**4.2.2** Check the positions of timing marks - the camshaft sprocket (positioned by Pin), the crankshaft (keyway vertically upwards) and the fuel pump (approx 1-o-clock position aligned with bolt head directly behind sprocket. ie. one tooth to right of vertical axis).

**4.2.3 NOTE:** If the engine variant has an adjustable camshaft sprocket, remove one bolt and slacken the other two by one turn.

**4.2.4** Fit the new timing belt, commencing at the crankshaft gear. Ensure that the marks on the belt are aligned with the timing marks on the camshaft, HP pump and crankshaft sprockets. There should be **19 tooth spaces** between camshaft and HP pump timing marks and **51 tooth spaces** between crankshaft and HP pump marks.

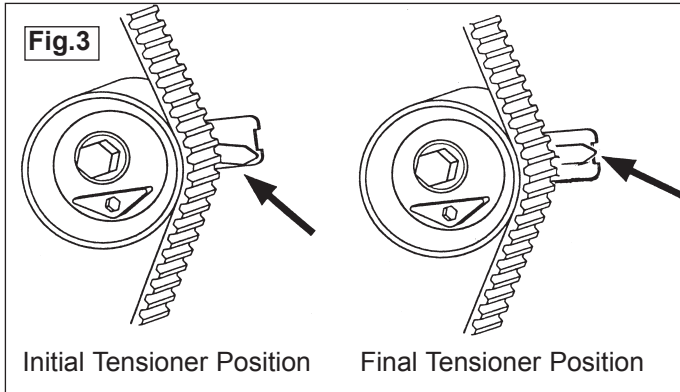

### 4.3 Belt Tensioner Positions

Apply initial belt tension by turning the tensioner **anti-clockwise** so the “pointer” is positioned **below** the “notch. (Fig.3)

**4.3.1 NOTE:** If adjustable camshaft sprocket fitted, check that the remaining two sprocket bolts are not at the end of their elongated slots. Re-fit the 3rd bolt and tighten all 3 x sprocket retaining bolts.

**4.3.2** Re-fit the crankshaft pulley and remove the VS4562A and VS125/R1 Locking Pins. Rotate the crankshaft two turns and return to a position where the crankshaft and camshaft locking pins can be inserted to check timing is correct, **then remove the Locking pins.**

**NOTE:** If camshaft timing pin cannot be inserted, slacken the 3 x sprocket retaining bolts, turn the sprocket using wrench on centre bolt, and insert pin. Do not re-tighten the 3 x retaining bolts at this stage. They are tightened after setting the final tensioning position.

**4.3.3** For final tensioner position, slacken tensioner bolt (1 turn only) and adjust tensioner **clockwise** until the “pointer” **aligns** with the “notch” -

**4.4 1.9dCi Engines (F9Q 600, 700 and 800 Series dCi)**  
F9Q 1.9dCi engines require VS125/R1 Crankshaft Locking Pin and two tools for belt tensioner adjustment – VS4760/T6 and VS4759.V3.

Remove RH road wheel and splash guards. As it is necessary to remove the RH engine mounting/bracket when removing and installing the timing belt, the engine must be supported from below.

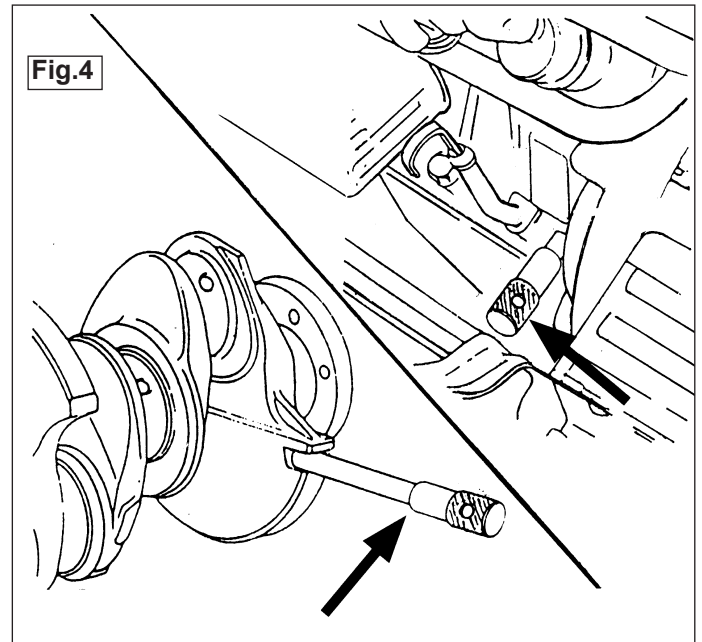

### 4.4.1 VS125/R1 Crankshaft Locking Pin

On most 1.9dCi engine variants position the camshaft sprocket timing mark just before the mark on the rear cover. Remove crank pin blanking plug from cylinder block, insert VS125/R1 Crank Locking Pin and rotate crank slowly in a **clockwise** direction until Pin enters crankshaft to determine TDC. (Fig.4).

**NOTE:** On some variants the timing cover has a ‘window’ to view the camshaft sprocket timing mark.

**4.4.2** Check camshaft timing marks align, remove VS125/R1 Pin and crankshaft pulley.

**4.4.3** Re-fit VS125/R1 Locking Pin, slacken tensioner and remove old belt.

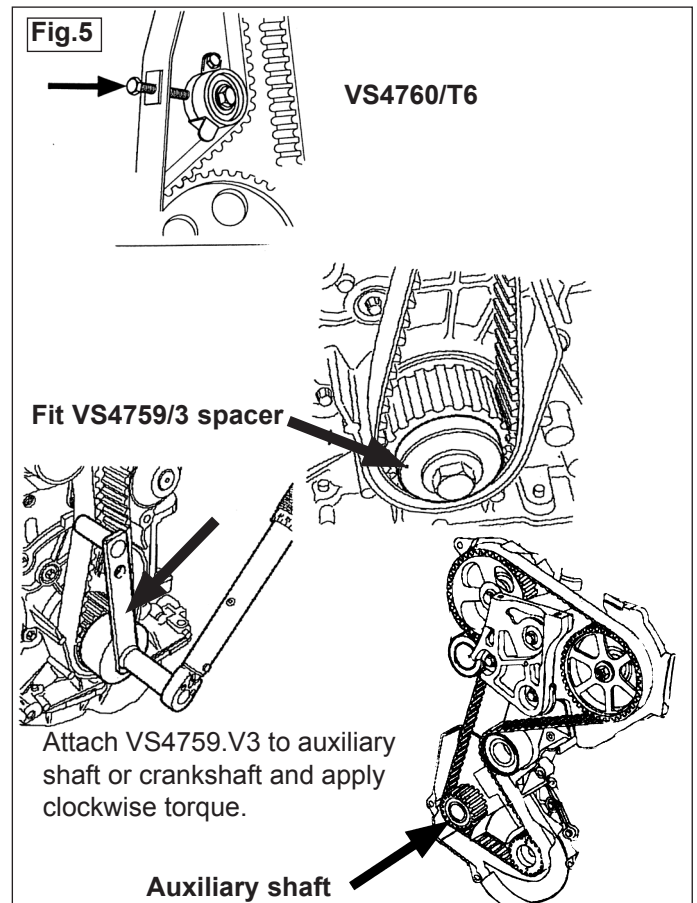

Attach VS4759.V3 to auxiliary shaft or crankshaft and apply clockwise torque.

Auxiliary shaft



#### 4.4.4 VS4760/T6 and VS4759.V3 Tensioning Tools

Fit new timing belt ensuring all timing marks align.

VS4759.V3 is used to apply a pre-tensioning torque to a newly fitted belt. It comprises a main lever arm and the range of adaptors required to cover the F9Q 600, 700 and 800 series of dCi engines. The selection of the appropriate adaptor allows the main arm to be attached to the auxiliary shaft or crankshaft to provide a pivot point for the lever arm.

If the engine has an auxiliary shaft then VS4759.V3 must use this point, not the crankshaft.

If no auxiliary shaft, then attach to the crankshaft. Spacer VS4759/3 is fitted to the crankshaft end using the existing crank pulley bolt in order to 'lock' the crankshaft gear in position when turning the crankshaft (do not over-tighten). (Fig. 5)

Screw VS4760/T6 Adjusting Bolt through the tensioner bracket until the tensioner pulley contacts the belt.

**IMPORTANT:** Remove VS125/R1 Crank Locking Pin.

**4.4.5** Select the Adaptor which has the appropriate inside diameter size to fit over the auxiliary shaft or crankshaft. Assemble the Adaptor (VS4759/2 or /4 or /5 or /6), onto the VS4759/1 Arm and slide it over the auxiliary shaft or over the VS4759/3 Spacer (previously installed on the end of the crankshaft) or directly onto the crankshaft gear (/6).

**4.4.6** Ensure that the bar of the Main Arm is extended across the entire width of the belt, pull out the bar to extend it is necessary.

Using a torque wrench apply a **clockwise** (pre-tensioning) torque of 11Nm. Tighten VS4760/T6 Bolt until the tensioner comes into contact with the timing belt. Remove VS4759.V3 tool.

**4.4.7** Fit a suitable belt tension gauge to belt, between the crankshaft and the tensioner pulley, and screw in the VS4760/T6 Bolt until the reading specified by Renault is obtained.

**4.4.8** Rotate the crankshaft 4 turns and return to TDC. (Check position by inserting VS125/R1 Pin but **DO NOT leave Pin in crankshaft**). Ensure all timing marks align.

**4.4.9 IMPORTANT:** Repeat the tensioning procedure using VS4760/T6 and VS4759.V3 Tools.

**WARNING:** It is imperative that the belt tension specified by Renault is achieved on both the first and second (final tensioning) applications. Some variants of the 1.9dCi engines require one reading on the first tensioning and a different tension reading on the second (final) belt tensioning.

#### 4.5 2.2 & 2.5dCi Engines (G9T / G9U)

Timing belt replacement on these twin cam, common rail diesels requires the use of VS4763 Crankshaft Locking Pin and VS4764 Camshaft Setting Plate Set.

**4.5.1 IMPORTANT:** The Exhaust Camshaft Setting Plate of the VS4764 Set is also used to establish correct tension of the timing belt during the belt replacement procedure. Belt replacement is straightforward but the tensioning sequence must be strictly adhered to. Correct use of the Exhaust Cam Setting Plate provides initial and final belt tensioner positions and it is therefore essential that its operation is clearly understood.

Remove the R-H road wheel, inner wing panel, torque reaction link, auxiliary belt and belt covers. As it will be necessary to remove the engine mounting/brackets to remove and fit the timing belt, the engine must be supported from below.

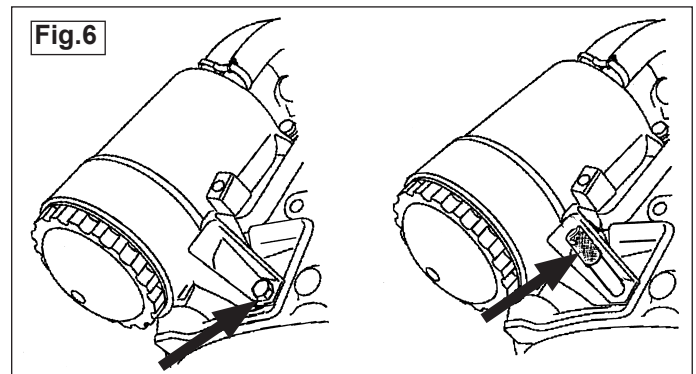

#### 4.5.2. VS4763 Crankshaft Locking Pin

The oil filter housing bolt is removed to provide an entry point for VS4763 Pin to locate into and lock the crankshaft. (Fig. 6).

**4.5.3** Insert VS4763 Pin and slowly turn the crank **clockwise** until the Pin fully enters. Rock the crankshaft slightly to ensure the Pin has engaged correctly. The crank pulley mark should be in the bottom position and No.1 cylinder must be at TDC on ignition stroke. (No.1 cylinder is at the flywheel end).

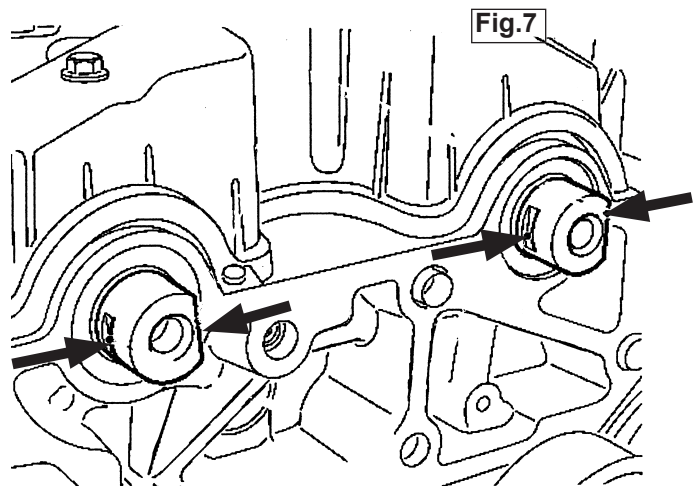

**4.5.4** Check that the camshafts are aligned correctly – the flat surfaces on the ends of the camshafts should be in a vertical position and the grooves in the camshafts must be on the left-hand side. (Fig.7).

If this is not so, then remove the VS4763 Crank Pin, rotate the crankshaft one turn and re-fit the Crank Locking Pin.

**Fig.8** VS4764/1 Exhaust

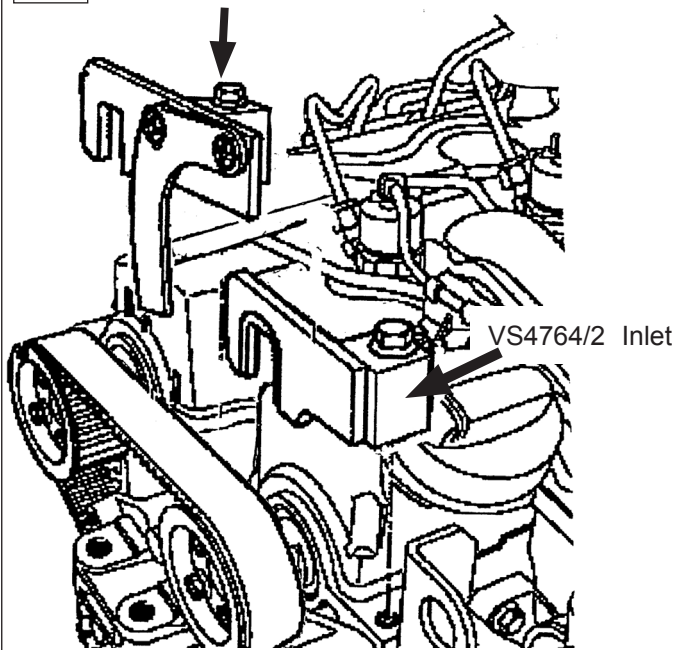

#### 4.5.5 VS4764 Camshaft Setting Plate Set

**Comprises:** VS4764/1 Exhaust Cam Setting Plate  
VS4764/2 Inlet Cam Setting Plate

Fit Setting Plate VS4764/1 to the exhaust camshaft, fitting it into the groove in the camshaft and bolting firmly in position.

Slacken the three camshaft sprocket bolts. Adjust camshaft position to fit Setting Plate if necessary.

Fit Setting Plate VS4764/2 to the inlet camshaft, fitting it into the groove in the camshaft and bolting firmly in position.

Slacken the three sprocket bolts. Adjust camshaft position to fit Setting Plate if necessary. (Fig.8)

**NOTE:** To assist alignment of the Setting Plates and installation of the fixing bolt, turn camshaft slightly so that the Setting Plate is allowed some movement and is not forced down tightly onto the cylinder head. Start the bolt into the threaded hole and then tighten down.

**4.5.6 Release the tensioner bolt and remove the old timing belt together with the exhaust camshaft sprocket only.** (Sprockets are flanged and removal of the exhaust sprocket facilitates fitting of the belt).

#### 4.5.7 Fitting new belt and tensioning

**NOTE:** Vehicle maker advises that both tensioner and guide roller need to be replaced with new. When fitting new tensioner ensure the dowel pin is located in the groove of tensioner.

Ensure the VS4763 Crankshaft Locking Pin is inserted correctly.

Ensure VS4764 Camshaft Setting Plates are fixed and firmly bolted in position.

**IMPORTANT:** Check that the three Inlet camshaft sprocket bolts are loose and are in the centre of the slotted holes.

Fit the new timing belt together with the exhaust

**NOTE:** It is our policy to continually improve products and as such we reserve the right to alter data, specifications and component parts without prior notice.

**IMPORTANT:** No liability is accepted for incorrect use of this product. **WARRANTY:** Guarantee is 12 months from purchase date, proof of which will be required for any claim.

**INFORMATION:** For a copy of our latest catalogue and promotions call us on 01284 757525 and leave your full name and address, including postcode.

camshaft sprocket.

**IMPORTANT:** Loosely screw in the three exhaust camshaft sprocket bolts and ensure they are in the centre of the slotted holes.

Check that the Lever Arm on the Exhaust Cam Setting Plate moves freely up and down.

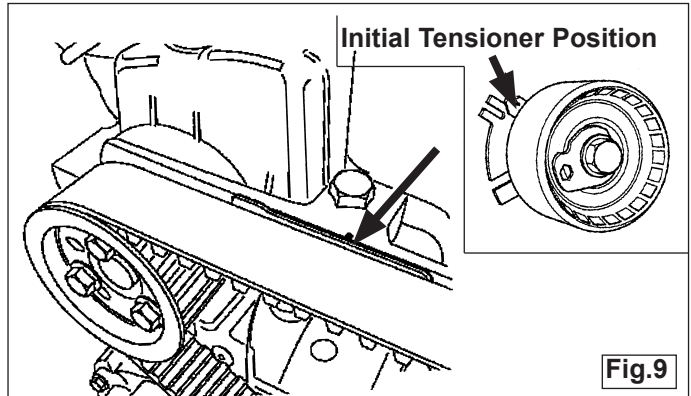

#### 4.5.8 Initial Tensioner Position

Turn the tensioner **anti-clockwise** so it reacts upon the Lever Arm of the Setting Plate until the upper part of the Arm (not the small raised portion) **is level with the upper edge** of the Setting Plate. The tensioner pointer should now be in a position, as (Fig.9).

Tighten tensioner bolt and the six camshaft sprocket bolts, to the specified torque.

Remove the Crank Pin and both Cam Setting Plates.

Turn the crankshaft clockwise two revolutions.

Insert the Crank Locking Pin to establish TDC No.1 cyl. position and fit the two Camshaft Setting Plates, bolting them firmly in place as before.

**IMPORTANT:** Check that the Lever Arm moves freely up and down.

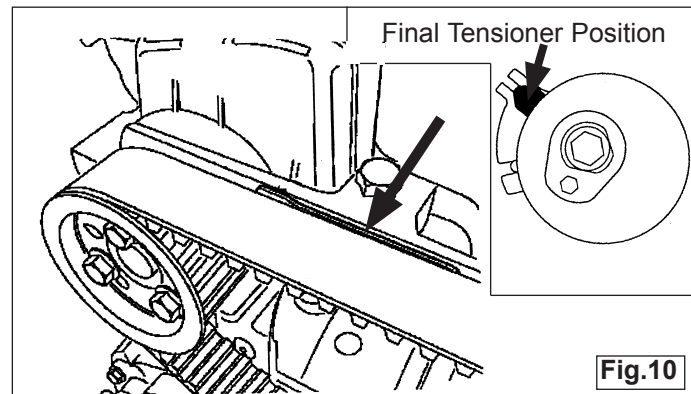

#### 4.5.9 Initial Tensioner Position

Slacken the six camshaft sprocket bolts and tensioner bolt.

Turn the tensioner **clockwise** so it reacts upon the Lever Arm and the **small raised portion** of the Lever Arm is level with the upper edge of the Setting Plate.

Check that the tensioner pointer is now aligned within the groove (Fig.10).

Tighten tensioner bolt and the six camshaft sprocket bolts to the specified torque and remove all tools.