



# INSTRUCTIONS FOR MULTI SERVICE RESET TOOL Model: VS300

Thank you for purchasing a Sealey Product. Manufactured to a high standard this product will, if used according to these instructions and properly maintained, give you years of trouble free performance.

**⚠ IMPORTANT:** PLEASE READ THESE INSTRUCTIONS CAREFULLY. NOTE THE SAFE OPERATIONAL REQUIREMENTS, WARNINGS AND CAUTIONS. USE THIS PRODUCT CORRECTLY AND WITH CARE FOR THE PURPOSE FOR WHICH IT IS INTENDED. FAILURE TO DO SO MAY CAUSE DAMAGE OR PERSONAL INJURY, AND WILL INVALIDATE THE WARRANTY. PLEASE KEEP INSTRUCTIONS SAFE FOR FUTURE USE.

## 1. SAFETY INSTRUCTIONS

- WARNING!** Ensure health and safety, local authority, and general workshop practice regulations are strictly adhered to
- DO NOT** use tool if damaged.
- ✓ Maintain the tool in good and clean condition for best and safest performance.
- ✓ If required ensure the vehicle to be worked on is adequately supported with axle stands, ramps and chocks.
- ✓ Wear approved eye protection. A full range of personal safety equipment is available from your Sealey dealer.
- ✓ Wear suitable clothing to avoid snagging. Do not wear jewellery and tie back long hair.
- ✓ Account for all tools and parts being used and do not leave them near the engine.

**IMPORTANT:** Always refer to the vehicle manufacturer's service instructions, or proprietary manual to establish the current procedure and data. These instructions for use are provided as a guide only .

## 2. VEHICLE APPLICATIONS

Make	Model	Our Ref	Incl in set
BMW	316i, 316i Touring, 318i, 318i Touring, 320i, 325i, 3525i Touring, 325iX, 325iX Touring, 518i, 520i, 525i, 530i, 535i, Z1, 728i, 730i, 735i, 740i, 750i	VS300/BMW	Yes
Audi	A3 from 1997, A4 from 1994, A6 from 1995, A8 from 1996		Yes
Ford	Galaxy (1.9Tdi)		Yes
Mercedes	C180, C200, C220 CDI, C230, C240, C250, C280, C43 AMG, E200, E200 CDI, E220 CDI, E240, E250 Diesel, E250 Turbo Diesel, E280, E280 4Matic, E290 Turbo Diesel, E320, E320 4Matic, E300 Turbo Diesel, E430, E55 AMG (All models from 1997)	VS300/M	No
Seat	Alhambra from 1996, Arosa from 1997		Yes
Skoda	Octavia from 1997		Yes
GM	Astra-G from 1998		Yes
Volkswagen	Golf MkIV from 1999, Passat from 1997, Sharan from 1996	VS300/VW	Yes
Volvo	850 1996 to 1997, S40 from 1997, V40 from 1997, S70 from 1997, V70 from 1997		Yes
Rover	R75	VS300/A/75	No
BMW	3 Series from 1999		Yes
Mercedes	A Class from 1998	VS300/A/75	No

### OPTIONAL 38 PIN CONNECTOR.

The following MERCEDES-BENZ models may be connected by purchasing optional 38 pin Diagnostic Connector, (see chapter 5 VS300/M)

To obtain this product contact us on our sales phone number (see back page).

Models From 1997 on:

C180, C200, C220CDI, C230, C240, C250, C280, C43 AMG, E200, E200CDI, E220CDI, E240, E250 DIESEL, E250 TURBO DIESEL, E280, E280 4MATIC, E290 TURBO DIESEL, E320, E320 4MATIC, E300 TURBO DIESEL, E430, E55 AMG.

**NOTE:** It is our policy to continually improve products and as such we reserve the right to alter data, specifications and component parts without prior notice.

**IMPORTANT:** No liability is accepted for incorrect use of this equipment

**WARRANTY:** Guarantee is 12 months from purchase date, proof of which will be required for any claim.

**INFORMATION:** Call us for a copy of our latest catalogue on 01284 757525 and leave your full name and address including your postcode.



Sole UK Distributor,  
Sealey Group,  
Bury St. Edmunds, Suffolk.



01284 757500



01284 703534

**E-mail:** sales@sealey.co.uk

### 3. CONNECTOR LOCATIONS

#### 3.1. Use Diagnostic Connector as in figure 1. for following models.

MERCEDES. "A" A140 '98 onward: Connector is located under the steering column (fig 3.1).  
 SKODA. Octavia '97 on, VW. Polo '96 onward: Located under the steering column to left (2).  
 AUDI A6 '97 on, SEAT Arosa '97 onward: Located under the steering column to the right (3).  
 AUDI A3'97 on Ford Galaxy. VW Golf MKIV '98 on. VOLVO S40 '97 on, VOLVO V40 '97 on.  
 Connector is located at bottom of the centre console under a removable plastic panel near ash tray (4).  
 AUDI A8 '96 on. Astra-G '98 on Passat '97 onward: Connector is located under a removable plastic panel adjacent to the handbrake (5).

AUDI A4 '96 onward: Located under a removable plastic panel adjacent to rear ash tray (6).

#### 3.2. Use Diagnostic Connector as in figure 2. for following models.

AUDI A6 '97 on A4 '94 to '96: Connector is located in engine bay on driver's side in relay/fuse box (7).

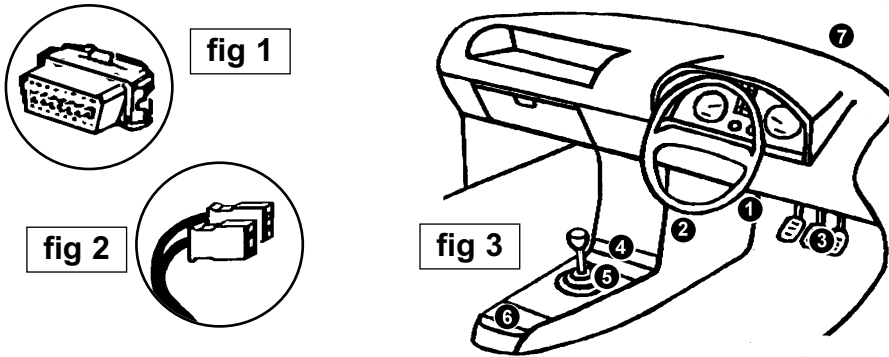

#### 3.3. Use Diagnostic Connector as in figure 4. for following models.

**BMW** 316i, 316i Touring, 318i, 318i Touring, 320i, 325i, 325i Touring, 325iX, 325iX Touring, 518i, 520i, 525i, 535i, Z1 728i, 730i, 735i, 740i, 750i: Connector is located in the engine bay, but, the exact location can vary. Figure 5 indicates the possible locations.

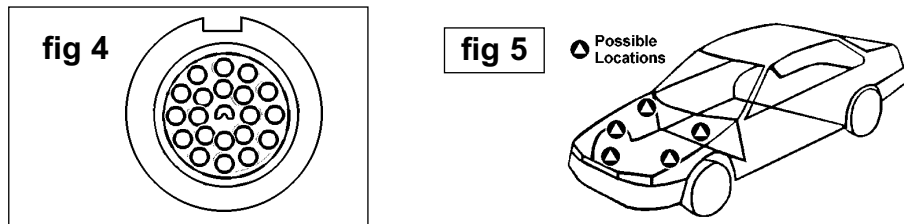

### 4. OPERATING INSTRUCTIONS

- 4.1. Connect the tool to the vehicle's diagnostic connector (see part 3 for connection point). The tool will power up automatically and the green LED will light when ready.
- 4.2. Turn the ignition on.
- 4.3. Press the appropriate key to perform the service operation required. The reset tool will automatically identify the vehicle to which it has been connected.

**Note:** Service intervals are preset values defined by vehicle manufacturer where appropriate.

#### V.A.G.

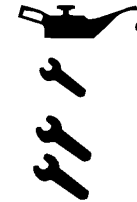

Resets the oil service interval

Resets the service interval 1 and the oil service interval.

Resets the service interval 1 Service interval 2 and the oil service interval.

#### VOLVO



Resets the Volvo service light. After the reset has been carried out, turn the ignition off and then on again. The service light will then go out.

#### VAUXHALL



Resets the Vauxhall service light.

#### MERCEDES



Resets the Mercedes service light.

#### BMW



Resets the oil service light.



Resets the service inspection light.

#### ROVER



Resets the Rover R75 service light.

During the reset function the green LED will flash continuously. Once the procedure has been completed the green LED will stay ON for 2 seconds, then go OFF for 6 seconds before going back to the start.

### 5. OPTIONAL COMPONENT VS300M

#### Optional 38 pin Diagnostic Connector (fig 6) for following MERCEDES-BENZ models:

To obtain this product contact us on our sales phone number (see back page).

Models from 1997 onward:

C180, C200, C220CDI, C230, C240, C250, C280, C43 AMG, E200, E200CDI, E220CDI, E240, E250 DIESEL, E250 TURBO DIESEL, E280, E280 4MATIC, E290 TURBO DIESEL, E320, E320 4MATIC, E300 TURBO DIESEL, E430, E55 AMG.

Connector is located in the engine bay, but, the exact location may vary. Figure 7 indicates possible locations.

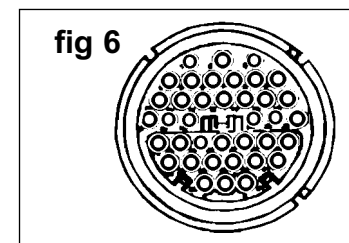

fig 6

fig 7

