

MODELS:	<b>VS2110</b>	<b>VS2111</b>	<b>VS2112</b>	<b>VS2114</b>	<b>VS2115</b>
---------	---------------	---------------	---------------	---------------	---------------

Thank you for purchasing a Sealey product. Manufactured to a high standard this product will, if used according to these instructions and properly maintained, give you years of trouble free performance.

**⚠ IMPORTANT: PLEASE READ THESE INSTRUCTIONS CAREFULLY. NOTE THE SAFE OPERATIONAL REQUIREMENTS, WARNINGS AND CAUTIONS. USE THE PRODUCT CORRECTLY AND WITH CARE FOR THE PURPOSE FOR WHICH IT IS INTENDED. FAILURE TO DO SO MAY CAUSE DAMAGE AND/OR PERSONAL INJURY AND WILL INVALIDATE THE WARRANTY. PLEASE KEEP INSTRUCTIONS SAFE FOR FUTURE USE.**

## 1. SAFETY INSTRUCTIONS

❑ **WARNING! DO NOT** use these kits or the components from these kits on diesel fuel systems or high pressure petrol injection systems. Ensure you have read and understood the safety aspects of dealing with the fuel injection system and petrol in general before commencing.

**IMPORTANT:** Always refer to the vehicle manufacturer's service instructions, or proprietary manual to establish the current procedure and data. These instructions are provided as a guide only.

❑ **WARNING! Ensure all Health and Safety, local authority, and general workshop practice regulations are strictly adhered to when using product.**

- ✓ Maintain tools in good and clean condition for best and safest performance. DO NOT use test kit if damaged.
- ✓ Account for all tools and parts being used and do not leave them in, or on the engine after use.
- ✓ Ensure you have read and understood the safety aspects of dealing with the fuel injection system and petrol in general before commencing.

### Fuel Hazards:

Petrol fumes and battery gases are explosive.

- x DO NOT smoke or allow an open flame or sparks in the work area.
- ✓ Keep a dry chemical (class B) fire extinguisher near to the working area.
- ✓ Avoid fire hazard by using caution when disconnecting fuel lines and installing adaptors - some spillage is inevitable.
- ✓ When connecting to or disconnecting from a fuel system, relieve pressure from system and wrap a cloth around the fuel line fitting to absorb any fuel leakage. Wipe up fuel spills immediately.

### Fuel Leaks

- ✓ Constantly check gauge and adaptor connections for leakage. If you see leakage turn off the ignition or disable the fuel pump, relieve fuel pressure if necessary and correct leaks before continuing.

- x DO NOT let fuel drip or spill onto a hot engine.
- ✓ Wipe up fuel spills immediately.
- ✓ When using tee adaptors, secure hose with hose clamps to ensure leak-free connections.
- ✓ Check all adaptor sealing washers and 'O' rings are in good condition before use.
- ✓ When connecting the hose coupler to the Test Port, Tee and In-Line\Banjo Adaptors make sure that the coupler is correctly seated onto the adaptor.
- x DO NOT allow fuel to remain in the adaptors or hoses after use. To clear any fuel trapped in the gauge/hose assembly after use, hold the gauge vertically with hose coupler end in a suitable container. Depress coupler valve stem and at the same time depress pressure relief button situated under the gauge.

### Personal / Operation

- ✓ Wear approved eye protection. A full range of personal safety equipment is available from your Sealey dealer.
- ✓ Keep yourself, clothing and test equipment away from all moving or hot engine parts.
- ✓ Do not wear jewellery and tie back long hair.
- ✓ Before performing a test with the engine running (unless the manufacturer's manual states otherwise), set the parking brake and place the gear selector in neutral or park, and block the drive wheels.
- ✓ Exhaust gas contains deadly poisonous gases. The test area must be well ventilated - route the exhaust gas outdoors.
- ✓ Before repairing the fuel system, turn off the ignition switch and disconnect the battery per manufacturer's procedure.
- ✓ Never disconnect the battery whilst the engine is running.



**VS2110** - Test Port Entry Kit



**VS2111** - Single Point /  
Electronic Systems Test Kit



**VS2112** - Mechanical  
Systems Test Kit

## 2. INTRODUCTION

### PETROL INJECTION SYSTEMS : Pressure testing diagnosis on a wide range of Multi-point, Single Point, Electronic and Mechanical Injection Systems.

A modular range comprising 3 x Test Kits and 2 x Workshop Combination Sets each designed to cover fuel injection system groups. Each kit progressively builds up the application coverage - start with Gauge / Hose and adaptors for Test Port entry, increase to encompass Single Point (TBi) and Electronic systems (EFi), and finally, add Mechanical Fuel Injection (CIS) applications.

## 3. APPLICATIONS

A wide range of petrol fuel injection systems including:-

**ALFA ROMEO:** EFi

**BOSCH:** K, KE, KE3, L, LE2, LE3, LH, Jetronic.

**BOSCH MOTRONIC:** M1.3, M1.7, M2.5, M3.1, ML4.1, MA3.0, A2.2 SPi

**BENDIX-FENIX:** EFi,

**CHRYSLER:** SM.

**DAIHATSU:** EFi.

**FIAT:** SPi, Weber 1AW, EFi

**FORD:** EEC1V, EFi, Weber CFi.

**GM:** Multec SPi, EFi, Simtec EFi.

**HONDA:** PGM-Fi.

**HYUNDAI:** EFi.

**ISUZU:** 1-Tec.

**KIA:** EFi.

**LUCAS:** L Hotwire, P Digital.

**MAGNET MARELLI:** EFi, G5/G6 Mono.

**MAZDA:** EG<sub>i</sub>.

**MITSUBISHI:** EC<sub>i</sub>, MPi.

**NISSAN:** EFi, ECCS.

**RENAULT:** R Electronic

**RENIX:** MPi.

**ROVER:** SPi, PGM-Fi, M.E.M.S. SPi/MPi

**SUBARU:** MPFi, SPFi.

**SUZUKI:** E.

**TOYOTA:** EFi, TCCS

**VW:** Digijet, Degifant, VAG MPi

**WEBER-MARELLI:** 1AW, CFi

## 4. FUEL INJECTION SYSTEMS

### FUEL INJECTION SYSTEMS - BASICS

Most modern fuel injection systems are **Electronic** - EFi (eg. Ford EEC 1V). Older systems are **Mechanical** - CIS (eg. Bosch K-Jetronic).

Systems can be **Single Point** fuel injection (Throttle Body Injection TBi or Central Fuel Injection CFi) or **Multi-Point** fuel injection (Port Fuel Injection PFi).

**Single point systems** inject fuel from a position on the intake manifold above the throttle plate, a single injector supplying all cylinders. **Multi-point systems** have individual injectors for each cylinder, injecting at a point on the intake manifold near the intake valve. These injectors are mounted on / feed fuel via a 'fuel rail' (fuel distribution rail).

On both single point and multi-point systems, the fuel lines comprise 'the supply' which supplies fuel to the injector(s) and 'the return' which returns excess fuel to the tank. The fuel pressure regulator is fitted between the supply and the return sides and maintains constant system pressure.

**FUEL PRESSURE DIAGNOSIS:** - The Petrol Injection System Pressure Test Kit is used to identify system faults via system pressure readings and fuel delivery rate.

Faults such as

- Blocked lines
- Blocked filters
- Reduced output from pump
- Faulty regulator

Fuel pressure is affected by the condition of the fuel pipes and components that make up the supply and return sides of the system. Lower than normal pressure is usually due to a faulty supply side component. Higher than normal pressure is usually caused by a faulty return side component.

A fault in the fuel pressure regulator could result in higher or lower pressure, since it connects the supply to the return side.

**Lower than normal pressure:** - Normally attributed to faults such as clogged filter, restriction (kink or bend) in supply line, defective fuel pump, defective pressure regulator or low pressure in tank caused by improper venting.

A low pressure condition on most systems can be isolated by pinching off the return line and checking the fuel pressure. If the fuel pressure increases, the pressure regulator may be faulty, if the fuel pressure does not increase, carry out tests for blockages in the supply pipes and filters.

**Higher than normal pressure:** - Usually attributed to faults such as defective fuel pressure regulator, restriction (bend or kink) in return line or excessive tank pressure caused by a poor vent system. Isolate the area of restriction by disconnecting the fuel return pipe starting from the pressure regulator (only after relieving system pressure). Both outlets from the disconnection must be routed to a fuel container. If the pressure is at the specified level when the regulator is functioning normally, then the restriction is between the disconnected return pipe and the tank. If the pressure remains high the regulator may be defective.

**Maintaining system pressure:** - Most fuel injection systems will maintain the fuel pressure after the engine has been switched off to ensure fuel for easier starting. If this pressure leaks the vehicle may be hard to start.

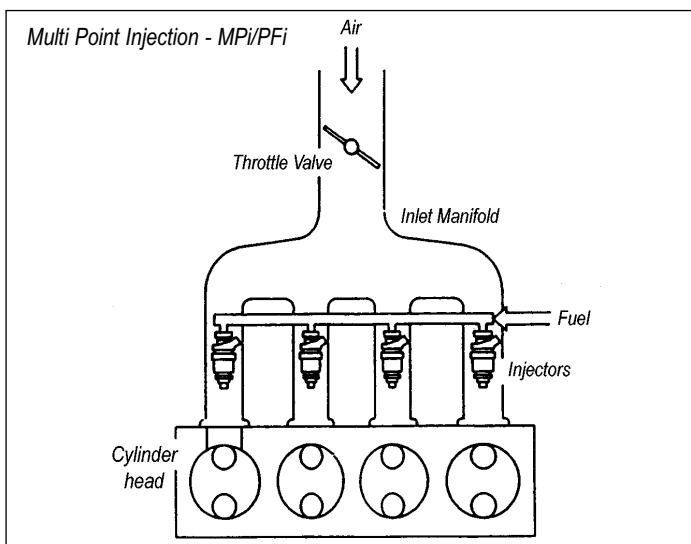
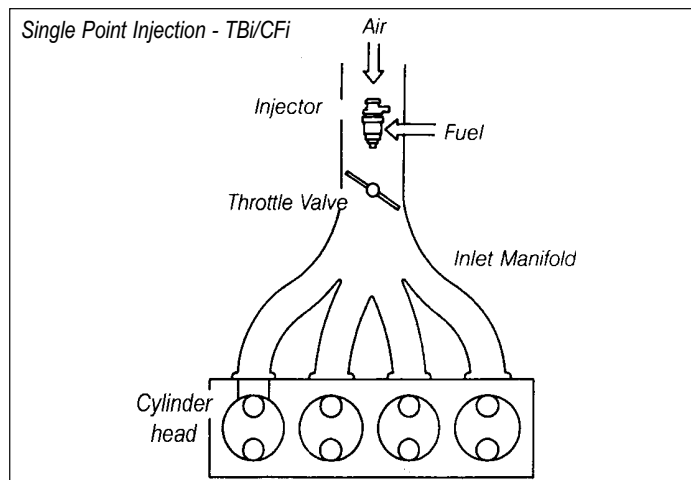

## 5. SYSTEM CONNECTION POINTS

The pressure gauge assembly of the Petrol Injection System Test Kit is connected to the fuel system, either in the fuel supply line or via a test port, whilst still allowing the engine to run and normal fuel flow to occur.

All pressure tests should be made at idle engine speed on the **supply** side of the system. On multi-point systems supply pressure may be tested at a special test port, often located on the fuel rail.

Testing can require disconnection of the fuel supply line, at a suitable point, and the installation of special adaptors to provide the means of attaching the pressure gauge and hose assemblies in-line.

If no specifications are available, connect the pressure gauge to the **supply line** as close as possible to the fuel rail, on some systems it may be possible to connect between the fuel rail and the regulator.

Follow the manufacturer's instructions regarding the connection location point. On Bosch K-Jetronic mechanical systems for example, connection is normally made in-line between the fuel distributor and the warm-up regulator.

### RELIEVING SYSTEM FUEL PRESSURE

**IMPORTANT** - Always adhere to manufacturer's procedures for relieving system pressure.

Fuel injection systems are pressurised, typically up to 3.5 bar on electronic systems.

Before disconnecting the fuel lines to connect adaptors and pressure gauge to fuel system, this fuel system pressure must be relieved, to prevent fuel spraying when a joint is disconnected.

Switch off ignition, loosen the fuel tank cap to relieve tank pressure, then re-tighten.

To relieve fuel pressure, it is necessary to prevent the fuel pump operating, whilst still allowing both injection and ignition systems to operate.

For example, the procedure may simply require the fuel pump relay, fuse or electrical connection to be disconnected, the engine run until it stalls, and then cranked over a number of times after it has stalled. However, on some electronic fuel injection systems removing the fuel pump fuse disables both the fuel pump and the injectors. Refer to manufacturer's procedure.

**IMPORTANT: DO NOT** assume that pressure in the fuel system has been relieved. If you 'open' the system in this condition fuel will spray out uncontrollably.

When disconnecting wrap a cloth around the fuel line fitting to absorb any fuel leakage.

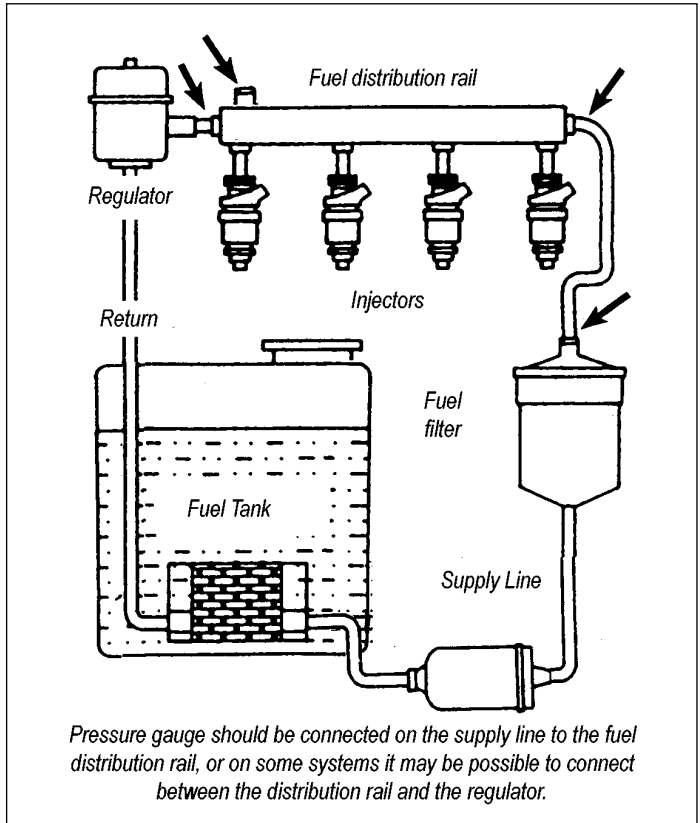

Multi-point Injection System ← Test Connection Points

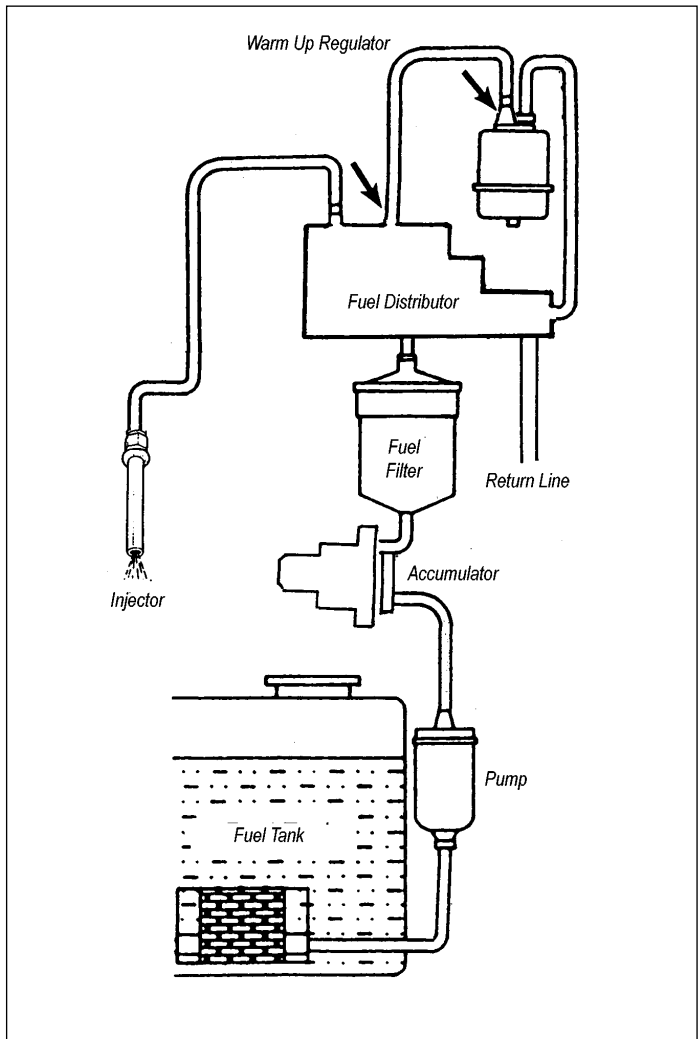

K-Jetronic Mechanical System ← Test Connection Points

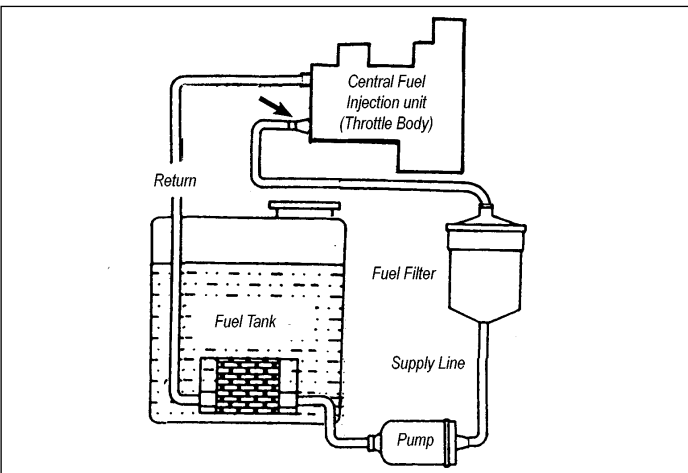

Single Point Injection System ← Test Connection Points

## VS2110: TEST PORT ENTRY KIT



### VS2110 KIT CONTENTS

(Refer to Identification Label in case)

1. VS2115/01 Pressure Gauge Assembly (Multi-point) - Dual Scale 0 -7 bar/0-100psi.c/w Gauge Cover & Hanging Hook
  2. VS2115/02 Relief Valve + Pressure & Vent Hose Assembly
- Test Port Connectors
3. VS210/08 Test Port Connector - Standard
  4. VS210/09 Test Port Connector - Small
  5. VS2115/04 Test Port Connector - Alfa/Fiat
- VS2110/84 Fitted Case + Insert

### Test Port connections.

System examples: **Bosch EFi/Motronic, Lucas EFi, Ford EEC1V, Chrysler SM, Alfa Romeo & Fiat systems**

For 'Std' Size Test Ports .....use VS210/08  
 For 'Small' Size Test Ports .....use VS210/09  
 For Alfa/Fiat Test Ports.....use VS2115/04

Many fuel injection systems provide a Test Port, most often comprising a male fitting with internal schrader type valve, usually located on the fuel rail.

These test ports provide the most straightforward pressure test connection to a fuel injection system.

Two sizes of **male thread** Test Port connections are common -  
 'Standard' - of the type on **GM systems**.  
 'Small' - often found on **Ford/Peugeot systems**.

Test Port Adaptors VS210/08 and VS210/09 are 'Flexible' to aid connection in difficult to access applications. They screw onto the male thread of the test port and depress the schrader valve. They provide the 'valved' male coupler which allows connection of the pressure Gauge and Hose Assembly directly onto the system.

### Alfa Romeo / Fiat

The 'Test Port' entry point on later Alfa Romeo and Fiat fuel injection systems is a male coupling with a female (internal) thread and deep-seated schrader valve.

VS2115/04 Test Port Adaptor is a 'banjo style' fitting which is designed to screw in to the female thread of the test port and provide a 'valved' connection point for Gauge and Hose Assembly. Once the Test Port Adaptor has been attached, its actuator pin is screwed in to depress the deep-seated schrader valve and allow fuel flow to the test gauge.

Screw the Adaptor assembly (banjo), in to the Test Port ensuring there is a Selon washer both sides of the banjo.

**Tighten pinch-tight only, sufficient to seal the assembly against the Selon washers.**

**WARNING: Care must be taken when tightening the Adaptor in the female thread of Test Port. DO NOT over-tighten or thread could be stripped. Tighten sufficiently to seal only.**

First, connect the female coupler of the Gauge/Hose Assembly onto the 'valved' male coupler of the Adaptor and then screw in the actuator pin to depress the schrader valve in the test port allowing fuel to flow to the gauge assembly.

**WARNING: After completing tests, the actuator pin MUST BE UNSCREWED to allow the schrader valve to close, BEFORE REMOVING THE ADAPTOR.**

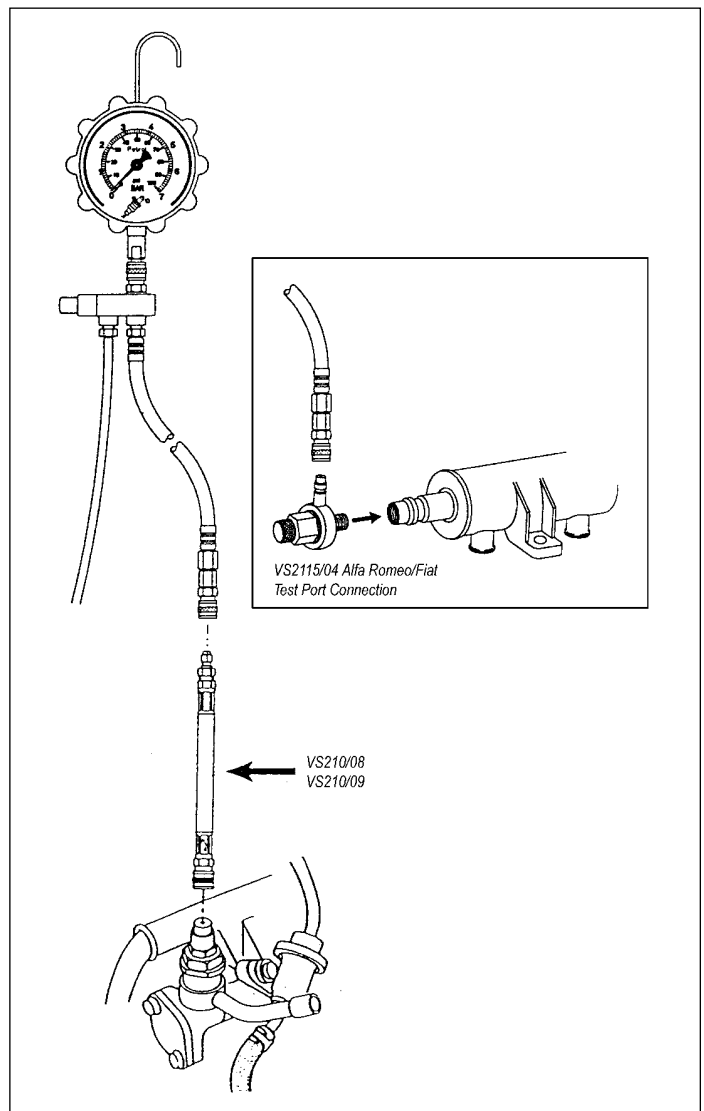

Test Port Adaptors

# VS2111: SINGLE POINT AND ELECTRONIC SYSTEMS TEST KIT

USE IN CONJUNCTION WITH TEST KIT VS2110



the fuel rail and at the fuel filter.

In-Line Banjo Bolt Adaptors are used to provide connection to the F. I. system by being substituted for the actual system banjo bolt. This then gives a 'valved' coupler connection for the pressure gauge & hose assembly to be attached.

**IMPORTANT:** When making this connection, ensure the Selon washers are in place top and bottom of the "banjo". Selon washers are provided in the Kit, and replacements are available by ordering Service Set VS2111/10

## Single Point (TBI) Systems Pressure Gauge

VS2111 Kit includes VS2115/03 Pressure Gauge for accurately measuring the lower system pressure of Throttle Body / Single Point Injection Systems.

Used in conjunction with the VS2115/02 Relief Valve & Hose Assembly in VS2110 Kit.

## VS2111 KIT CONTENTS

(Refer to Identification Label in case)

- 6. VS2115/03 Pressure Gauge Assembly (Single Point) - Dual Scale 0-2.5 bar / 0-35 psi c/w Gauge Cover & Hanging Hook
- 7. VS210/02 In-Line Tee, Valve & Hose Assembly.
- In-Line 'Coupler' Tee Adaptors**
- 8. VS210/04 Tee Adaptor - Ford/Land Rover
- 9. VS2115/05 Tee Adaptor - Rover
- 10. VS2115/06 Tee Adaptor Set (A&B) - Renault

### In-Line Banjo Adaptors

- 11. VS210/11 Banjo Adaptor - M8
- 12. VS210/12 Banjo Adaptor - M10
- 13. VS210/13 Banjo Adaptor - M12
- 14. VS210/14 Banjo Adaptor - M14
- 15. VS210/15 Banjo Adaptor - M12 x 1.25

### Threaded Adaptors

- 16. VS210/16 M6 Adaptor - Honda/Rover
- 17. VS210/27&/28 Conical Seat Adaptor Set - M16
- 18. VS210/25&/26 Conical Seat Adaptor Set - M14
- 19. VS210/29 Conical Seat Adaptor - 1/4BSP
- 20. VS210/30 Conical Seat Adaptor - M14 Long Female
- 21. VS210/31 Conical Seat Adaptor - M14 Long Male
- 22. VS2111/10 Replacement Seal Spares Kit
- VS2111/84 Fitted case + Insert

## In-Line Banjo Bolt connections

For M8 Banjo Connections.....use VS210/11  
 For M10 Banjo Connections.....use VS210/12  
 For M12 Banjo Connections.....use VS210/13  
 For M14 Banjo Connections.....use VS210/14  
 For M12 Banjo Connections  
 1.25 PGM-Fi systems.....use VS210/15

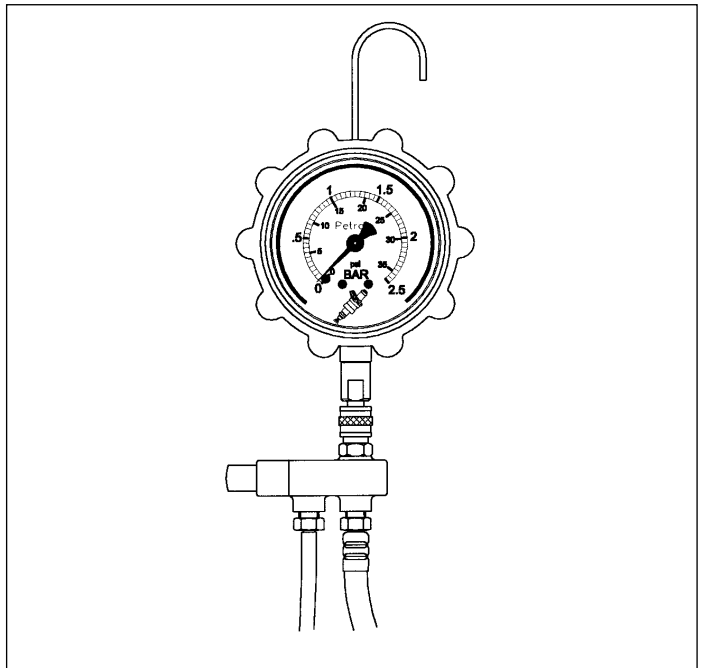

VS2115/03 Low Reading Pressure Gauge

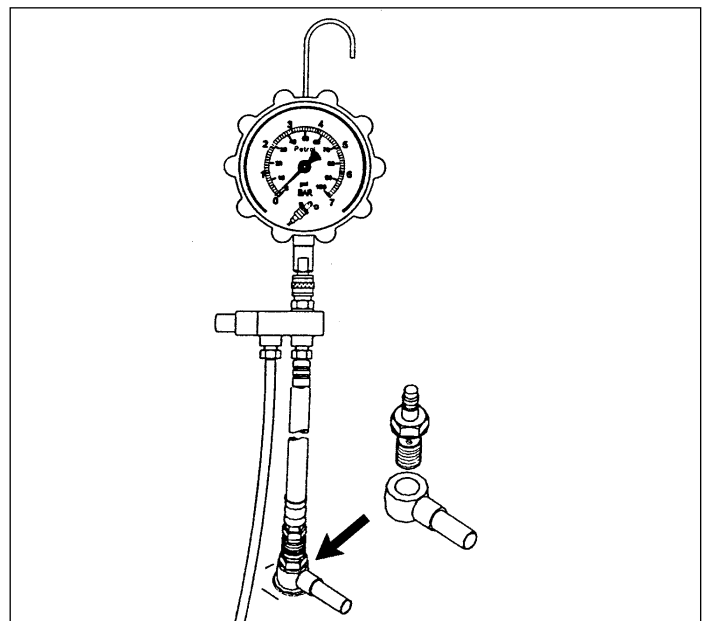

In-Line Banjo Bolt Adaptors

Banjo connections are commonly found on supply lines both at

## VS2111: KIT - *continued*

### In-Line 'Coupler' Tee connections -

System examples: **Ford CFi, Land Rover, Renault D7F/K7M/E7F, Rover MPi**

For **Ford/Land Rover** use VS210/04  
 For **Rover** use VS2115/05  
 For **Renault** use VS2115/06

This type of connection is identifiable via the system lines being connected with plastic quick couplers or couplers on the fuel rail / filter.

Releasing the coupler and disconnecting the line at this point allows the appropriate Tee Adaptor VS210/04 or VS2115/05 to be inserted into the female system coupler and the hose pushed onto the male system connection, allowing the Tee Adaptor to be fitted in-line. VS2115/06 Tee Adaptor Set (2 types) for Renault duplicate the 'Plastic' Tee coupler fitting of the system, again allowing In-Line connection.

**IMPORTANT:** When installing an In-Line Tee Adaptor the hose end connection **MUST BE** secured with hose clamp provided in the Kit.

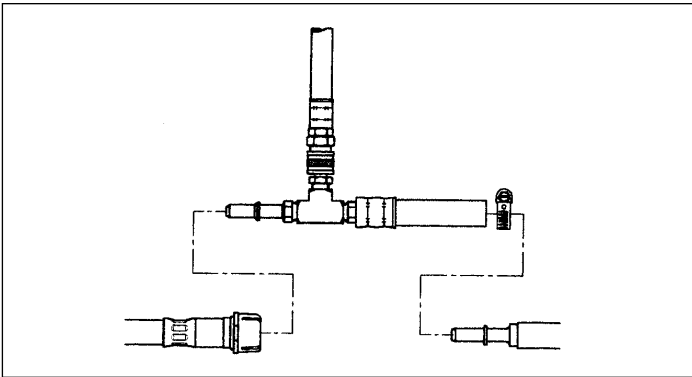

*In-Line Tee 'Coupler' Adaptors*

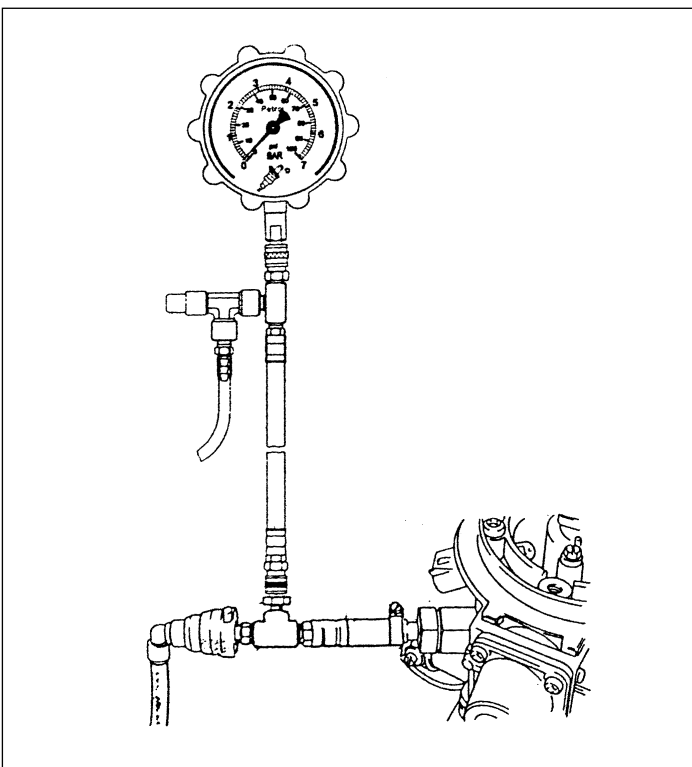

### Threaded connections - conical seating

USE IN CONJUNCTION WITH VS210/02 HOSE ASSEMBLY

	MALE	FEMALE
For <b>M14 Conical</b>	use VS210/25 + VS210/29	VS210/26
For <b>M16 Conical</b>	use VS210/27 + VS210/29	VS210/28
For <b>1/4" BSP Conical</b>	use VS210/25 + /26	VS210/29
For <b>M14 Conical Long Reach (MEMS system)</b>	use VS210/31	VS210/30

**NOTE:** The M14, M16 and 1/4" BSP adaptors must be used in combination to achieve the male/female conical seating connections to the systems in order to provide the two M12 male threads required to connect VS210/02 Tee/Valve & Hose Assembly in-line.

Threaded conical seat adaptors are used in exactly the same way as the standard threaded adaptors described later (Kit VS2112). The fuel line is separated and the male and female adaptors are attached to the open ends of the line. These adaptors then provide two M12 male threads onto which VS210/02 Tee/Valve & Hose Assembly is attached. This then creates an in-line attachment onto which the gauge/hose assembly is connected.

**NOTE:** For this in-line connection the valve of VS210/02 must be opened fully.

These adaptors do not seal onto 'O' rings, as with the standard adaptors, but seat directly onto the conical seatings found on certain system fuel line connections.

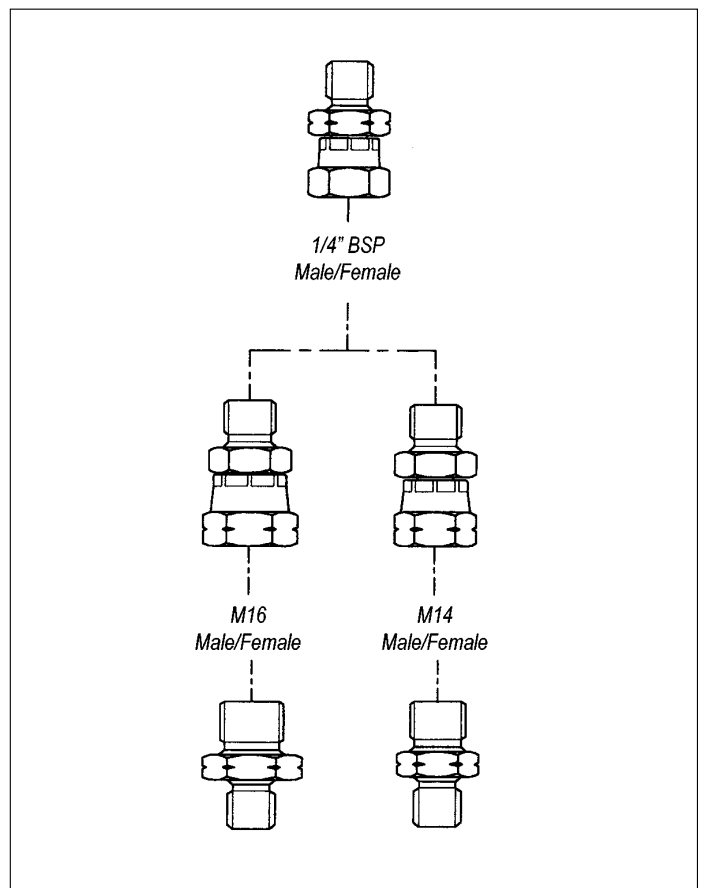

*Conical Adaptors - size combinations*

## VS210/02 Tee/Valve & Hose Assembly

Used to create in-line connection on the fuel line via Threaded Adaptors.

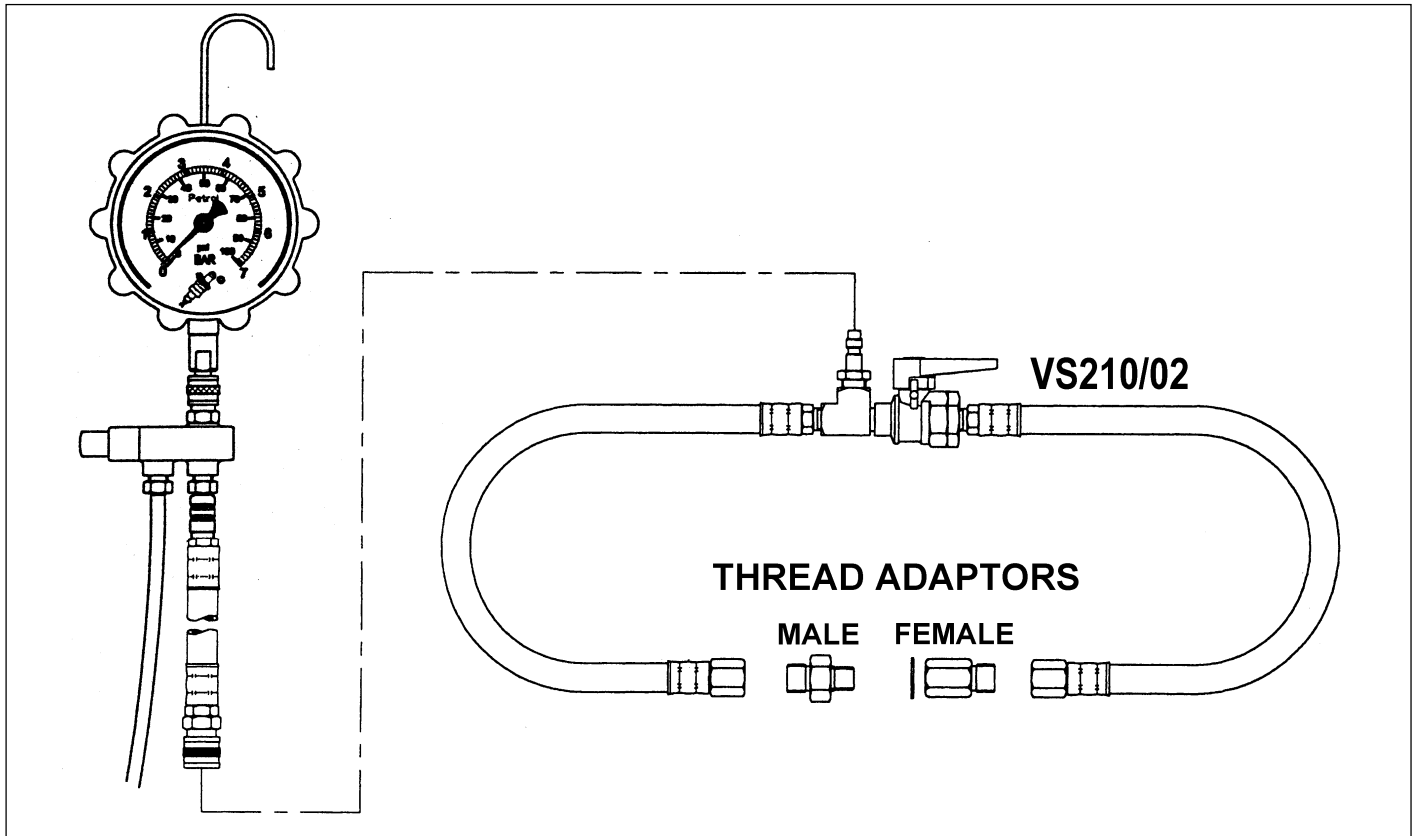

VS210/02 Tee, Valve and Hose Assembly

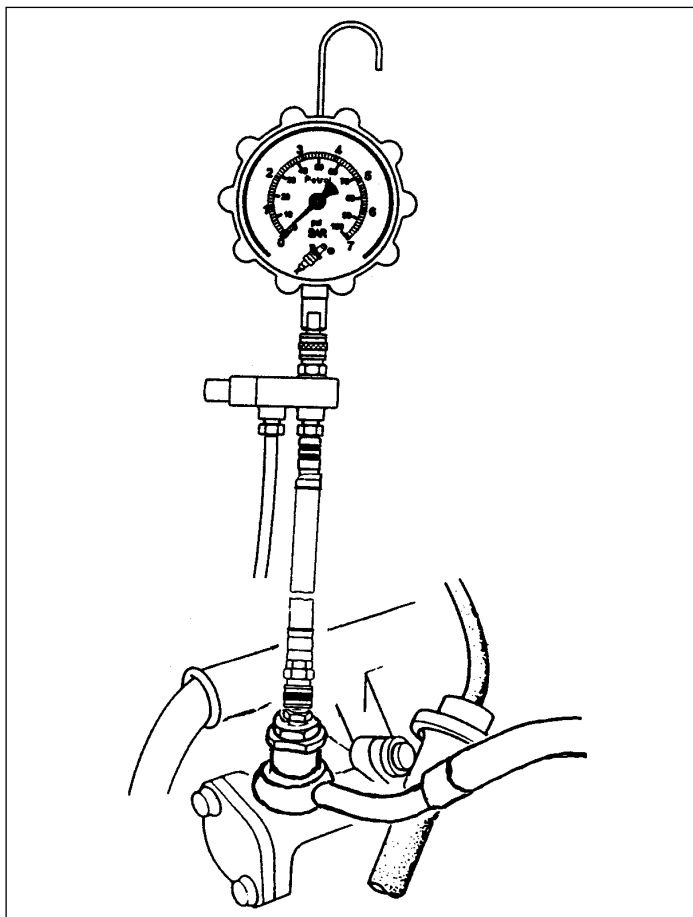

Gauge Assembly coupling directly to M6 Male Thread Adaptor - Rover/Honda

## VS210/16 Threaded Adaptor - M6

This Adaptor is for use on Rover/Honda systems. An M6 female entry point is provided on the fuel rail or supply line to the filter. The M6 bolt sealing this port is removed to give access for the VS210/16 adaptor. The gauge & hose assembly is attached directly to the adaptor male 'valved' coupling.

# VS2112: MECHANICAL SYSTEMS TEST KIT

USE IN CONJUNCTION WITH KITS VS2110 & VS2111



## VS2112 KIT CONTENTS

Item(Refer to Identification Label in case)

### In-Line Tee Adaptors

- 23 VS210/03 Tee Adaptor 3/8"
- 24 VS2115/07 Tee Adaptor 5/16"
- 25 VS210/05 Tee Adaptor 1/4"

### Male Threaded Adaptors

- 26 VS210/17 Adaptor - M8 Male
- 27 VS210/18 Adaptor - M10 Male
- 28 VS210/19 Adaptor - M12 Male
- 29 VS210/20 Adaptor - M14 Male

### Female Threaded Adaptors

- 30 VS210/21 Adaptor - M8 Female
- 31 VS210/22 Adaptor - M10 Female
- 32 VS210/23 Adaptor - M12 Female
- 33 VS210/24 Adaptor - M14 Female

### Long Threaded Adaptors

- 34 VS210/06 Adaptor - M8 Female
- 35 VS210/07 Adaptor - M8 Male
- 36 VS2112/10 Replacement Seal Set
- VS2112/84 Fitted Case + Insert

### In-Line Tee connections -

System examples: **Bosch EFi, Nissan EFi/ECCS, Renix, Subaru MPFi, Toyota EFi/TCCS, VW Digijet, Weber 1AW,**

- For 3/8" I.D. Fuel Lines use VS210/03
- For 1/4" I.D. Fuel Lines use VS210/05
- For 5/16" I.D. Fuel Lines use VS2115/07

Use of this type of connection is identifiable by the system supply fuel line being connected to the fuel rail / throttle body as a push-on flexible hose onto a male barb hose fitting, secured in place with a hose clamp.

Releasing the hose clamp and disconnecting the hose at this point allows the appropriate Tee Adaptor VS210/03, VS210/05 or VS2115/07, according to the inner diameter of the system supply line, to be placed in-line.

**IMPORTANT:** When installing an In-Line Tee Adaptor both the rail connection and the hose end connection **MUST BE** secured with hose clamps supplied.

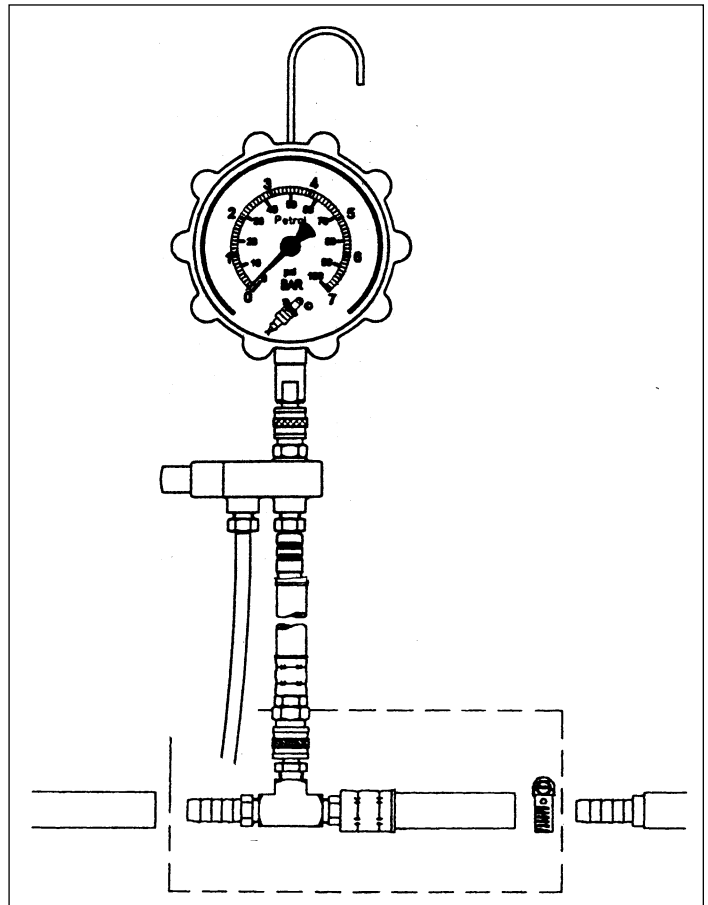

*In-Line Tee Adaptors*

### Threaded connections - standard

	MALE	FEMALE
For <b>M8 Threads</b>	use VS210/17	VS210/21
For <b>M10 Threads</b>	use VS210/18	VS210/22
For <b>M12 Threads</b>	use VS210/19	VS210/23
For <b>M14 Threads</b>	use VS210/20	VS210/24
For <b>M8 Threads Long Reach</b>	use VS210/06	VS210/07

Many older systems have threaded supply line connections and therefore VS2112 Kit provides a comprehensive range of Threaded Adaptors (also see Threaded connections - conical seating in VS2111 Kit).

When connecting onto the system using threaded adaptors the 'valved' coupler connection required to attach the pressure gauge/hose in-line to the system is provided by VS210/02 Tee/Flow Control Valve and Hose Assembly (provided in Kit VS2111).

All the Threaded Adaptors detailed above, have a M12 male thread opposite the male or female thread size listed. Therefore when the supply line is disconnected and the appropriate size male and female Threaded Adaptor fitted, two male M12 threads will be showing.

VS210/02 Tee/Valve & Hose Assembly has female M12 swivel connections on each hose end. These are screwed onto the M12 male threads which will be showing from the Threaded Adaptors used and therefore completes the in-line test connection onto the system.



**NOTE:** The M12 swivel connection to the M12 adaptor thread is a cone seating. Tighten using two spanners holding the Threaded Adaptor firmly with one whilst tightening the swivel with the other.  
 Ensure all connections are tightened fully and do not leak.  
 Ensure the Adaptor 'O' rings fully seal at the system connection points.

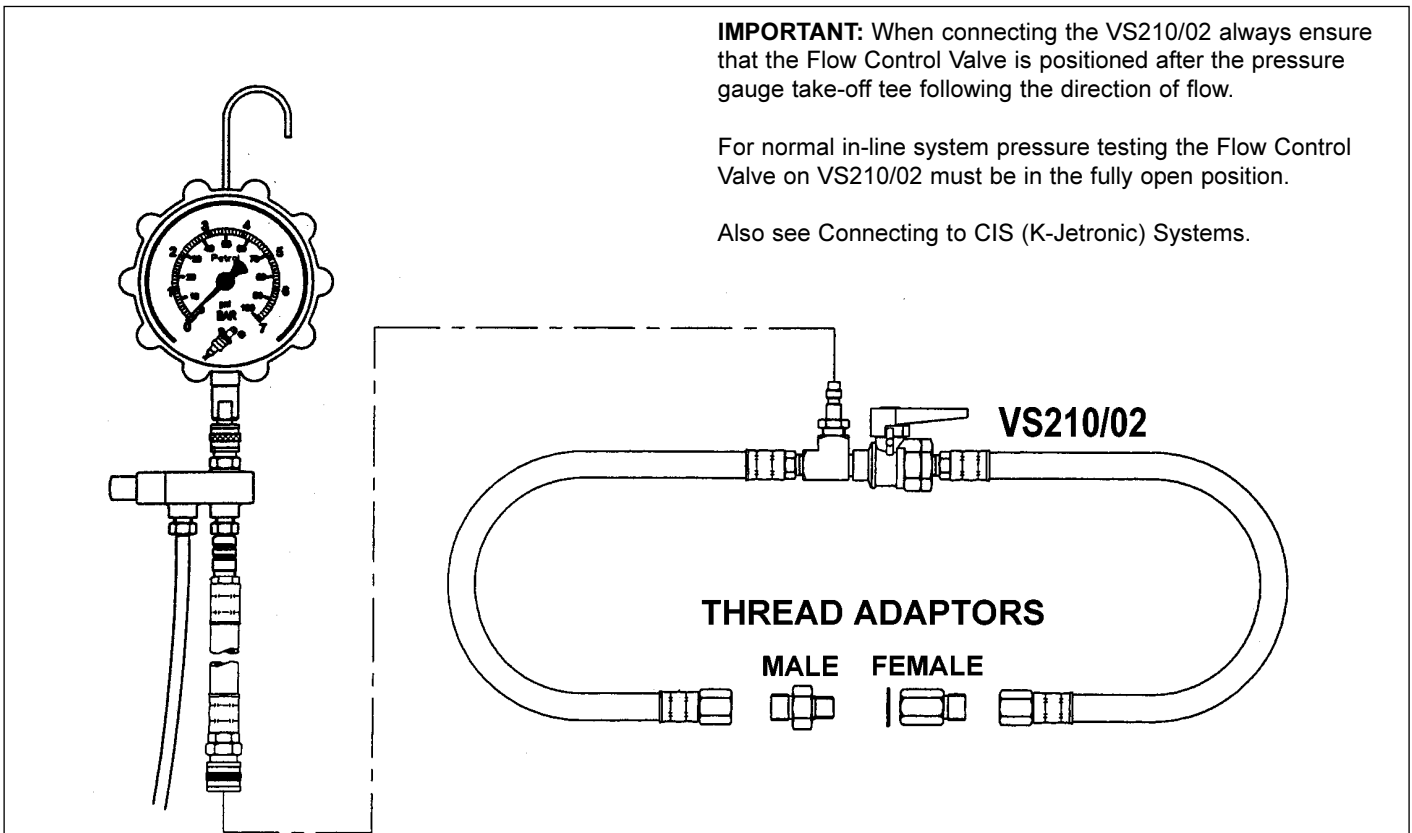

VS210/02 Tee, Valve and Hose Assembly for In-Line connection using threaded adaptors

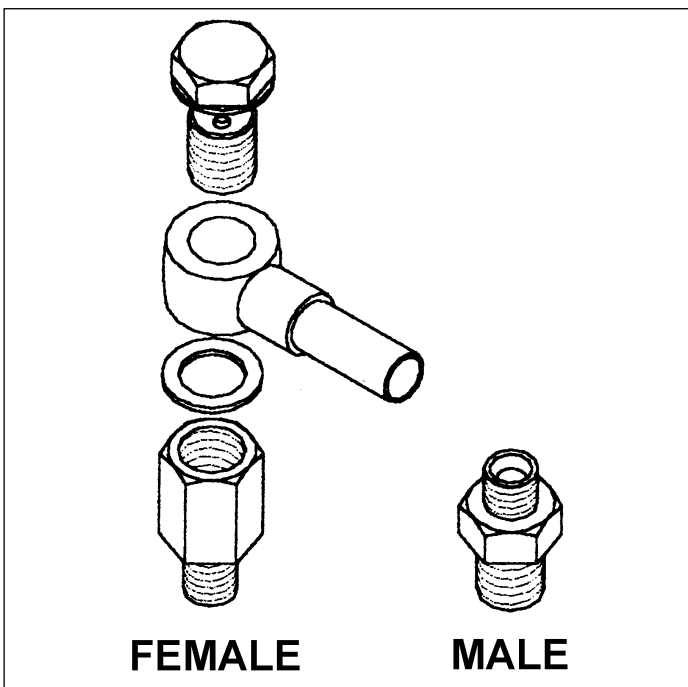

Threaded Adaptors to system banjo

**Threaded connections - Banjo when in-line Flow Control Valve is required.**

The range of Threaded Adaptors can also be used to place VS210/02 Tee/Valve & Hose Assembly in-line when the connection to a system banjo fitting is necessary and a Flow Control Valve is required, eg. on CIS(K-Jetronic) systems.

Disconnect the banjo fitting and leaving the bolt through the banjo (with top and bottom seals in place). Screw on to the banjo bolt the appropriate size of female threaded adaptor. Ensure the female adaptor threads fully up to the bottom seal, and tighten.

Screw into the threaded hole which has been left by removing the banjo fitting, the appropriate size male threaded adaptor..

Two male M12 threads will now be showing, allowing VS210/02 Tee/Valve & Hose Assembly to be connected and used to attach pressure gauge/hose to system.

**Typical In-Line connections using VS210/02 Tee/Valve and Hose Assembly with Threaded Adaptors**

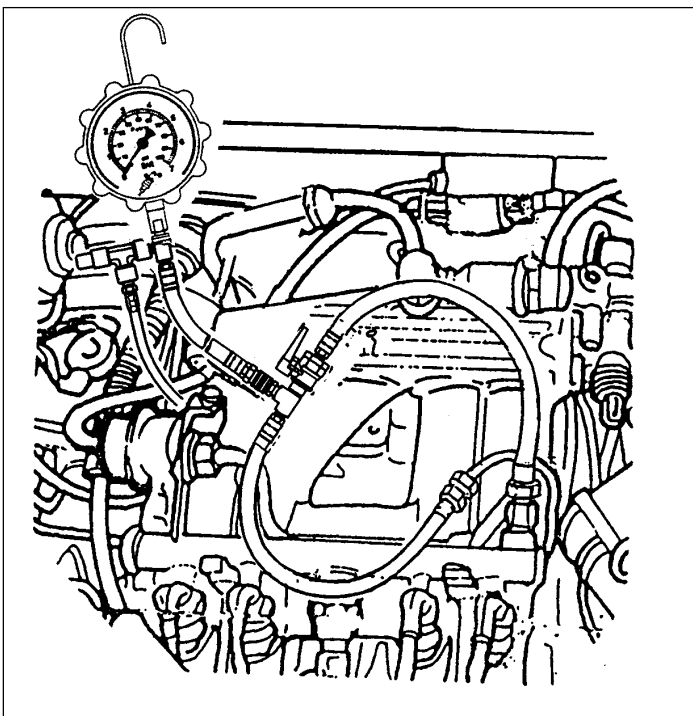

*Rover 216 Tee, valve and hose fitted in fuel line to fuel rail*

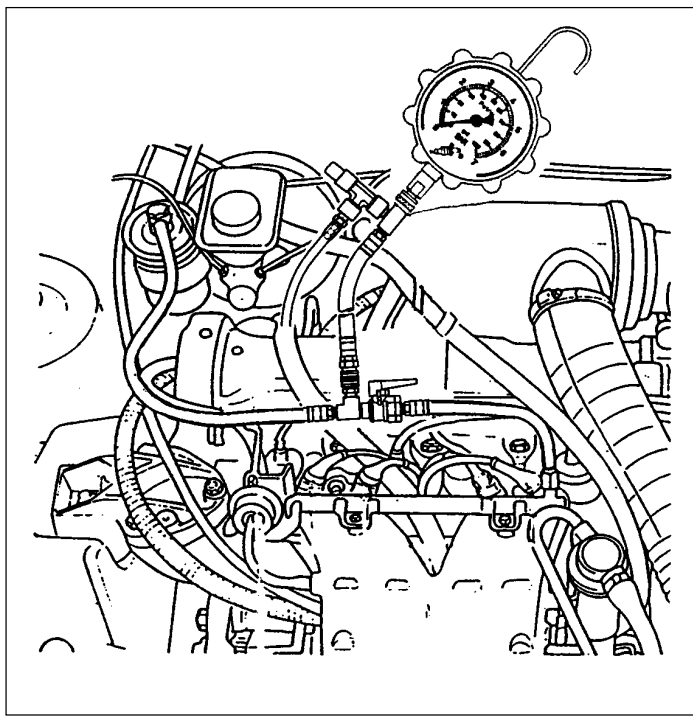

*Peugeot 205, 309, 405 Tee, valve and hose between filter and fuel rail*

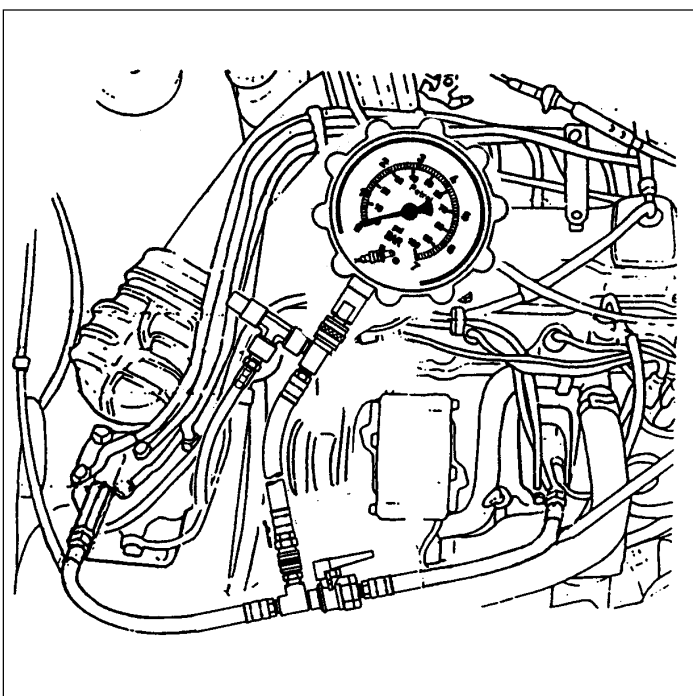

*Volkswagen Golf Tee/Flow Control valve and hose between fuel distributor and warm-up regulator.*

**Connecting to CIS (K-Jetronic ) mechanical systems**

Test connection to K-Jetronic systems is effected by fitting VS210/02 Tee/Valve & Hose Assembly in the fuel line between the fuel distributor and warm-up regulator using threaded adaptors.

In addition to providing the 'valved' coupler connection for attaching the pressure gauge/hose, VS210/02 has a Flow Control Valve which is required when carrying out tests on this system. The tests require the valve to be closed when checking Main System Pressure and Fuel Pump Check Valve tests and open for Control and Residual Pressure examination.

**IMPORTANT:** Always ensure that manufacturer's test procedures are understood and strictly adhered too, particularly those requiring the Flow Control Valve to be closed.

**NOTE:** When testing is completed, use fuel pressure relief valve attached to gauge to relieve pressure prior to disconnecting the test equipment to re-make the system. Always ensure the drain-off hose directs fuel away from the vehicle and into a suitable container.

## WORKSHOP SETS

Two Workshop Sets which provide lockable workshop storage for the VS2115 Series Fuel Injection Test Kits.



### VS2114 POPULAR SET

Comprises Test Kits - **VS2110** Test Port Entry Kit and **VS2111** Single Point/Electronic Systems Test Kit housed in Steel Workshop Cabinet.

Space provide to incorporate VS2112 Test Kit at later date.

### VS2115 MASTER SET

Comprises all 3 Test Kits - **VS2110**, **VS2111** and **VS2112** supplied in the Steel Workshop Storage Cabinet, and offering the most comprehensive fuel systems application coverage available today.



### VS2113

The Steel Workshop Cabinet is also available separately.

**NOTE:** It is our policy to continually improve products and as such we reserve the right to alter data, specifications and component parts without prior notice.



**IMPORTANT:** No liability is accepted for incorrect use of this product.



**WARRANTY:** Guarantee is 12 months from purchase date, proof of which will be required for any claim.

**INFORMATION:** For a copy of our latest catalogue and promotions call us on 01284 757525 and leave your full name and address, including postcode.



Sole UK Distributor  
Sealey Group,  
Bury St. Edmunds, Suffolk.

 01284 757500  
 01284 703534

 [www.sealey.co.uk](http://www.sealey.co.uk)  
 [sales@sealey.co.uk](mailto:sales@sealey.co.uk)