



INSTRUCTIONS FOR: CHAIN CLEANING KIT

MODEL No. **VS1817**

Thank you for purchasing a Sealey product. Manufactured to a high standard, this product will, if used according to these instructions, and properly maintained, give you years of trouble free performance.



IMPORTANT: PLEASE READ THESE INSTRUCTIONS CAREFULLY. NOTE THE SAFE OPERATIONAL REQUIREMENTS, WARNINGS & CAUTIONS. USE THE PRODUCT CORRECTLY AND WITH CARE FOR THE PURPOSE FOR WHICH IT IS INTENDED. FAILURE TO DO SO MAY CAUSE DAMAGE AND/OR PERSONAL INJURY AND WILL INVALIDATE THE WARRANTY. KEEP THESE INSTRUCTIONS SAFE FOR FUTURE USE.

1. SAFETY

- ❑ **WARNING!** Before use, ensure that the motorcycle is adequately supported during the chain cleaning process.
- ✓ Ensure that the motorcycle engine is switched off.
- ✓ Maintain the motorcycle support stand to be used in good condition for immediate use when required.
- ✓ Locate the motorcycle in a suitable work area. Keep area clean and tidy and free from unrelated materials and ensure that there is adequate lighting. Also ensure that the floor is level and flat (preferably concrete) to take the weight of the stand and the bike. **DO NOT** support the motorcycle on tarmac, as the surface may become unstable.
- ✓ Remove ill fitting clothing. Remove ties, watches, rings and other loose jewellery and contain long hair.
- ✓ Ensure that the bike is adequately secured to any stand used.
- ✓ Keep children and unauthorised persons away from the work area.
- ✓ Always use a good quality proprietary degreaser with the chain cleaner.

2. INTRODUCTION

2.1. Introduction

Specially designed to remove dirt from motorcycle chains. All four sides of the chain are cleaned at once by six stiff brush pads located in the tool. Designed for use with proprietary degreaser.

3. CONTENTS

- 3.1. Unpack the kit and check contents. If there are any damaged or missing parts contact your supplier immediately.

- | | |
|---------------------------|---------------|
| 1. Chain enclosure | 5. Nylon Cord |
| 2. Degreaser container | 6. 'Y' piece |
| 3. Plastic tube Int.Ø10mm | 7. Large Hook |
| 4. Plastic tube Int.Ø7mm | 8. Small Hook |

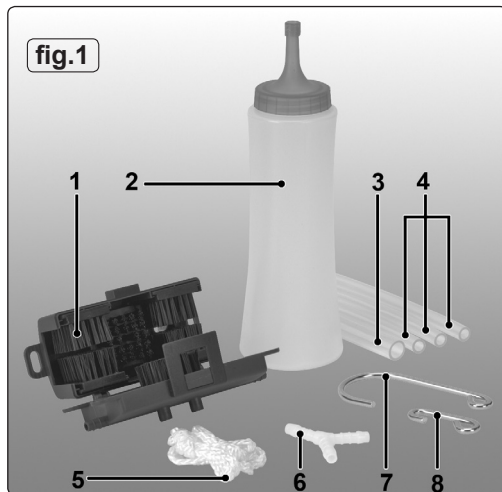

4. ASSEMBLY & OPERATION

- 4.1. Position the motorcycle in a suitable working area, checking that the surface on which it will be supported is level and flat (preferably concrete).
- 4.2. Support the rear wheel off the ground using a suitable stable stand. A paddock stand is ideal.

NOTE: It is our policy to continually improve products and as such we reserve the right to alter data, specifications and component parts without prior notice.

IMPORTANT: No liability is accepted for incorrect use of this product.

WARRANTY: Guarantee is 12 months from purchase date, proof of which will be required for any claim.

INFORMATION: For a copy of our latest catalogue and promotions call us on 01284 757525 and leave your full name and address, including postcode.

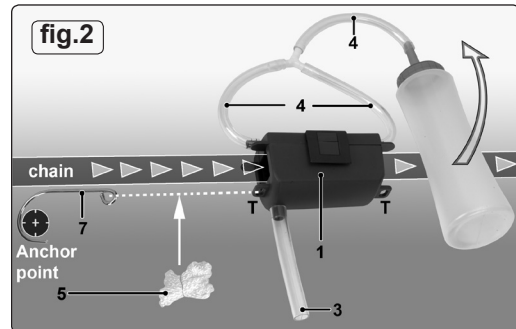

- 4.2. Remove the chain cover.
- 4.3. Push the larger diameter drain tube (3) onto the outlet on the lower surface of the chain enclosure as shown in fig.2.
- 4.4. Push a smaller diameter tube (4) onto the fluid inlets on either side of the chain enclosure lid as shown in fig.2.
- 4.5. With the chain enclosure cover open, position the enclosure beneath the lower part of the chain as shown in fig.3 and close the lid.
- 4.6. The chain enclosure must now be anchored to prevent it moving with the chain when the rear wheel is turned. Tie one end of the nylon cord (5) to one of the hooks provided, (7) or (8). Select a suitable anchor point on the motor cycle frame for the hook and feed the other end of the nylon cord through one of the tags on the chain enclosure. (See 'T' in fig.2). Adjust the length of the cord so that the chain enclosure is in the centre of the chain.
- 4.7. Using the 'Y' piece (6) connect together the inlet pipes attached to the chain enclosure lid and then connect the cleaning fluid bottle to the 'Y' piece using the remaining tube (4). See fig.2.
- 4.8. Place a suitable container under the outlet pipe (3) to collect the used degreaser.
- 4.9. Fill the degreaser container with a suitable proprietary degreaser and raise the container above the chain enclosure to start the flow of liquid.
- 4.10. Slowly turn the rear wheel of the motor cycle so that the chain travels through the chain enclosure keeping the anchor cord in tension. See diagrammatic representation in fig.2.
- 4.11. Continue until the chain is clean.
- 4.12. Disassemble the chain cleaner from the bike and dispose of old degreaser fluid according to Local Authority regulations.



Sole UK Distributor, Sealey Group,
Kempson Way, Suffolk Business Park,
Bury St. Edmunds, Suffolk,
IP32 7AR

01284 757500

01284 703534



www.sealey.co.uk



sales@sealey.co.uk