

For: FORD 1.8 Diesel Update.

Models: Fiesta 1.8D, Escort 1.8D & TD, & Mondeo 1.8TD, (96-).

1.



STANDARD PARTS LIST

1. VS115/01 Camshaft setting/locking plate

1. SAFETY INSTRUCTIONS

- ✓ Maintain the tools in good and clean condition for best and safest performance.
- ❑ **WARNING!** Ensure all health and safety, local authority, and general workshop practice regulations are strictly adhered to when using these tools.
- ✗ DO NOT use tool if damaged.
- ❑ **WARNING!** Incorrect or out of phase camshaft timing can result in contact between the valve head and the piston crown causing possible damage to the engine. Incorrect injection pump timing may cause excessive smoke emissions, poor starting and a low output of power.

IMPORTANT: Always refer to the vehicle manufacturer's service instructions, or proprietary manual to establish the current procedure and data. These instructions for use are provided as a guide only .

2. OPERATING GUIDE ONLY

CAMSHAFT SETTING / LOCKING PLATE.

The setting / locking plate is used to accurately align a datum slot in the end of the camshaft with the top face of the camshaft housing to hold the camshaft at the TDC position (fig 1).

Follow the service manual instructions to remove the camshaft cover and timing belt cover.

IMPORTANT: Note operational safety warning regarding incorrect or out of phase timing.

Keep tools clean and store in a safe dry area when not in use.

fig 1.

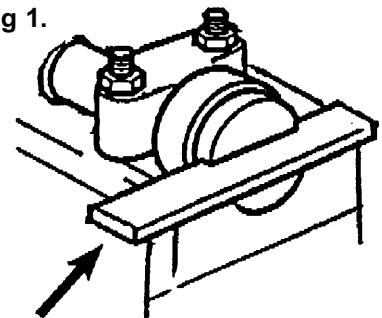

IMPORTANT: No responsibility is accepted for incorrect use of this equipment.

WARRANTY: Guarantee is 12 months from purchase date. Proof of purchase will be required for any claim.

INFORMATION: Please call us for a copy of our latest catalogue.