

# LUCAS CAV / ROTO DIESEL

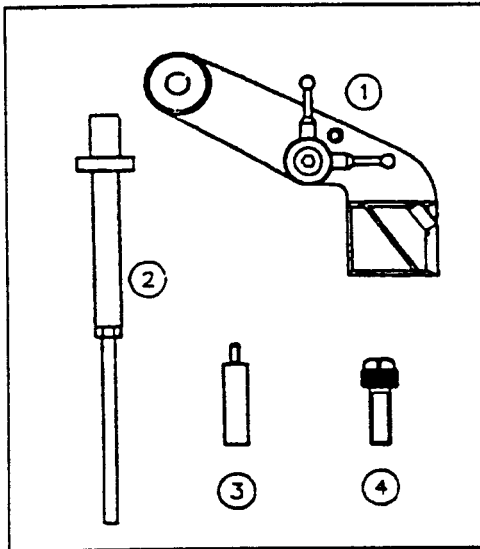

## STANDARD PARTS LIST

- |    |           |                    |
|----|-----------|--------------------|
| 1. | VS110/1&2 | Body Assembly      |
| 2. | VS110/3   | Indicator Pin      |
| 3. | VS110/4   | Gauge Extension    |
| 4. | VS106/4   | Slotted Thumbscrew |

### Application

LUCAS/CAV: DPC Rotary Injection Pump

### Introduction

Injection pump timing is the procedure to set the correct relationship between the injection pump plunger and the corresponding engine piston on its upward firing stroke. This relationship is critical for optimum operation of the diesel engine. VS110 is used for static timing, checking and adjustment, after servicing operations which may have affected the timing eg. removal of the timing belt or pump. Before using the tool refer to the manufacturer's service instructions to establish the procedure and data for each engine.

### Instructions for use

#### Checking timing

Set the engine to TDC on No.1 cylinder using the static timing points. Clean top of pump, remove cap from entry port, Fig 1 and insert pin VS110/3 into hole.

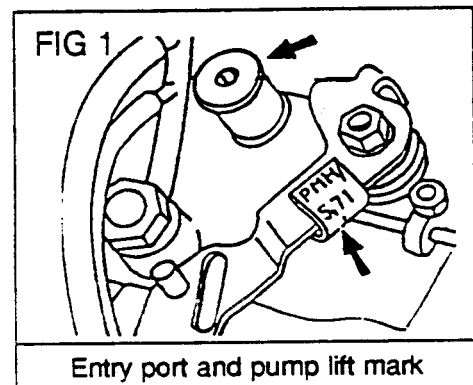

Locate and clamp bracket VS110/1 on pump spigot. Fit dial indicator AK9634M against bell crank and pin Fig.2, and preload indicator 1mm. Turn crankshaft 90 degree anticlockwise (opposite to normal rotation). Zero dial gauge. Turn crankshaft slowly in the normal direction of rotation to TDC and insert flywheel setting tool and injection pump pulley pins/bolts. Figs 3 & 4. Check that the amount of lift on the indicator corresponds to the figure stamped on the load lever plate Fig.1, or on side of pump (each pump is calibrated and marked during manufacture).

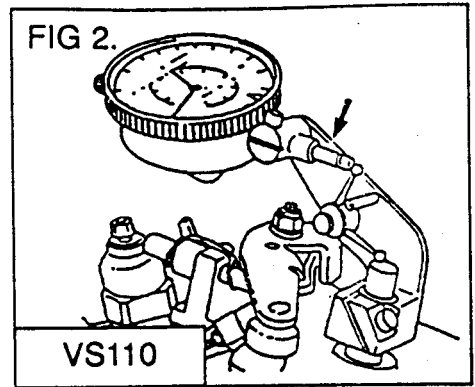

### Timing adjustment

Set the engine to TDC on No.1 cylinder and fit flywheel timing pin, injection pump pulley bolts and camshaft pulley bolt, Figs 3 & 4. Ensure injection pump is in the fully retarded position (tilted away from the engine). Clean top of pump, remove cap from entry port Fig.1 and insert pin of VS110 into hole. Locate and clamp bracket VS110 on pump spigot. Fit dial indicator AK9634M against bell crank and pin Fig.2, and preload indicator 1mm. Remove flywheel timing pin and pulley bolts. Turn crankshaft 90 degree anticlockwise (opposite to normal rotation). Zero dial gauge. Turn crankshaft slowly in the normal direction of rotation to TDC and insert flywheel setting tool and injection pump pulley pins/bolts Figs 3 & 4. Turn pump until dial indicator reading corresponds to figure stamped on load lever plate Fig.1, or on side of pump. Tighten pump retaining nuts and support bracket bolt to specified torque. Remove flywheel locking pin and pulley bolts. Turn crankshaft two complete turns in normal direction of rotation. Refit flywheel locking pin. Dial indicator should indicate specified figure +/- 0.04mm.

