

**FORD, SEAT, VW, AUDI, VOLVO**

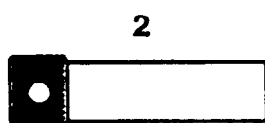
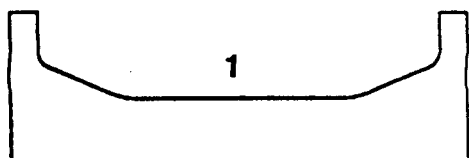

**STANDARD PARTS LIST**

- |    |         |                       |
|----|---------|-----------------------|
| 1. | VS101/1 | Camshaft Locking Tool |
| 2. | VS101/5 | Location Pin ø15.4 mm |

**Applications:**

**VS101/1 Camshaft Setting Plate**

- AUDI:** A4 1.9TDi, 80D/Turbo D, 100 5D, 100D/CLD, 100D Turbo 100, 2.5TD, 100, 2.5TDi.
- FORD:** Fiesta/Escort, Orion 1.6D, Galaxy 1.9 TD.
- VOLKSWAGEN:** Polo 1.3S, 1.4D, Golf/Jetta/Caddy 1.5/1.6 D/Turbo, Golf / Vento 1.9 TD, Passat/Santana D/Turbo, Passat 1.9 TD, Transporter 1.6D/1.7D/1.9D/Turbo 2.4D, LT 2.4D/Turbo D
- VOLVO:** 240D/Turbo, 740 D/Turbo, 760D/Turbo, 940D/Turbo
- SEAT:** Terra 1.3D/1.4D, Ibiza 1.9D/Turbo, Cordoba 1.9D/Turbo, Toledo 1.9D/TD

**VS101/5 Locking Pin**

- FORD:** Galaxy 1.9TD
- AUDI :** A4 1.9TDi, 80D/Turbo D, 100 5D, 100D/CLD, 100D Turbo
- VOLKSWAGEN:** Polo 1.3D, 1.4D, Golf/Jetta/Caddy 1.5/1.6D/Turbo, Golf/Vento 1.9TD, Passat/Santana D/Turbo, Transporter 1.6D/1.7D/1.9D/Turbo Transporter 2.4D, LT 2.4D/Turbo D
- SEAT:** Ibiza 1.9D/Turbo Cordoba 1.9D/Turbo.

## INTRODUCTION

VS104 is designed to lock the crankshaft and camshaft at a known datum point (TDC) whilst carrying out service procedures such as timing belt replacement, and injection pump timing.

### Instructions for use

Specific reference must be made to the manufacturer's service instructions to establish current procedures and data for each engine before any work commences.

### Warning

Incorrect or out of phase camshaft timing can result in contact between the valve head and the piston crown causing possible damage to the engine. Incorrect injection pump timing may cause excessive smoke emissions, poor starting and a low output of power

### VS101/1 Camshaft Locking Tool

The locking tool is used to accurately align a datum slot in the end of the camshaft with the top face of the camshaft housing to hold the camshaft at the TDC position.

Follow the service manual instructions to remove the camshaft cover and timing belt cover.

Turn engine in the normal direction of rotation until the camshaft locking tool can be inserted into the machined slot in the end of the camshaft.

If required feeler gauges of equal thickness can be inserted on either side of the locking tool until all free play has been eliminated. The camshaft is now locked and service work can now be carried out.

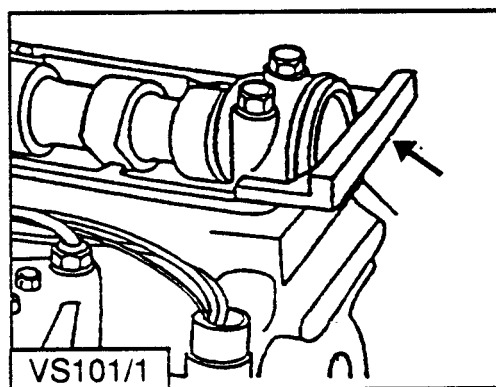

### VS101/5 Locking Pin

The locking pin is designed to pass through a datum hole in the timing belt pulley into a fixed timing hole in the engine.

A locking pin can be used at the injection pump pulley, the camshaft pulley, or at the flywheel.

Follow the service manual instructions to remove the engine timing cover where necessary. Insert the locking pin through the timing pulley or fixed timing hole.

Rotate the engine slowly in the normal direction of rotation until the point at which the pulley timing hole and the engine timing hole are aligned, the location pin can now be engaged to lock the engine in the correct position.

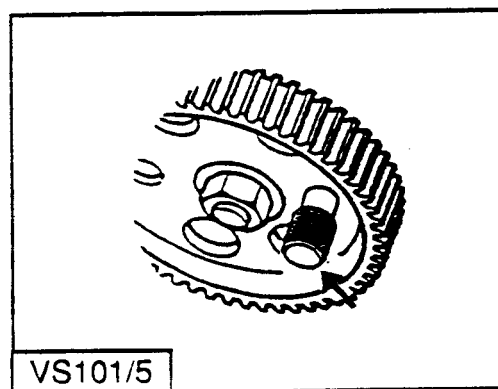

**SEALEY** Professional  
**TOOLS**  
AUTO SERVICE LINE



(01284) 757500



(01284) 767626

Original Date:- 030397  
Issue Date:- 030397  
Version Nbr:- 0  
Date Modified:- N/A