



## Instructions for: Model No. VS0463.V2 BRAKE CALLIPER THREAD REPAIR KIT M12

Thank you for purchasing a Sealey product. Manufactured to a high standard, this product will, if used according to these instructions, and properly maintained, give you years of trouble free performance.

**IMPORTANT:** PLEASE READ THESE INSTRUCTIONS CAREFULLY. NOTE THE SAFE OPERATIONAL REQUIREMENTS, WARNINGS & CAUTIONS. USE THE PRODUCT CORRECTLY AND WITH CARE FOR THE PURPOSE FOR WHICH IT IS INTENDED. FAILURE TO DO SO MAY CAUSE DAMAGE AND/OR PERSONAL INJURY AND WILL INVALIDATE THE WARRANTY. KEEP THESE INSTRUCTIONS SAFE FOR FUTURE USE.

### 1. SAFETY INSTRUCTIONS

- WARNING!** Ensure Health and Safety, local authority and general workshop practice regulations are adhered to when using tools.
- DO NOT** use tools if damaged.
- Maintain tools in good and clean condition for best and safest performance.
- Ensure that a vehicle which has been jacked up is adequately supported with axle stands.
- Wear approved eye protection. A full range of personal safety equipment is available from your Sealey dealer.
- Wear suitable clothing to avoid snagging.
- DO NOT** wear jewellery and tie back long hair.
- Account for all tools and parts being used and do not leave any in or near the engine.

### 2. INTRODUCTION

Quick and effective method of replacing brake calliper threads using M12 inserts. Stepped drill allows oversizing of the hole, allowing insert to be fitted. Features one alignment plate for precision drilling for new insert. Kit includes M12 tap, step drill, insert locator, two washers with centre roller bearing and ten replacement inserts in storage case.

### 3. SPECIFICATION

3.1. Calliper Insert Thread Size: M12x1.5mm Replacement Inserts: VS0463R (Pack of 10)

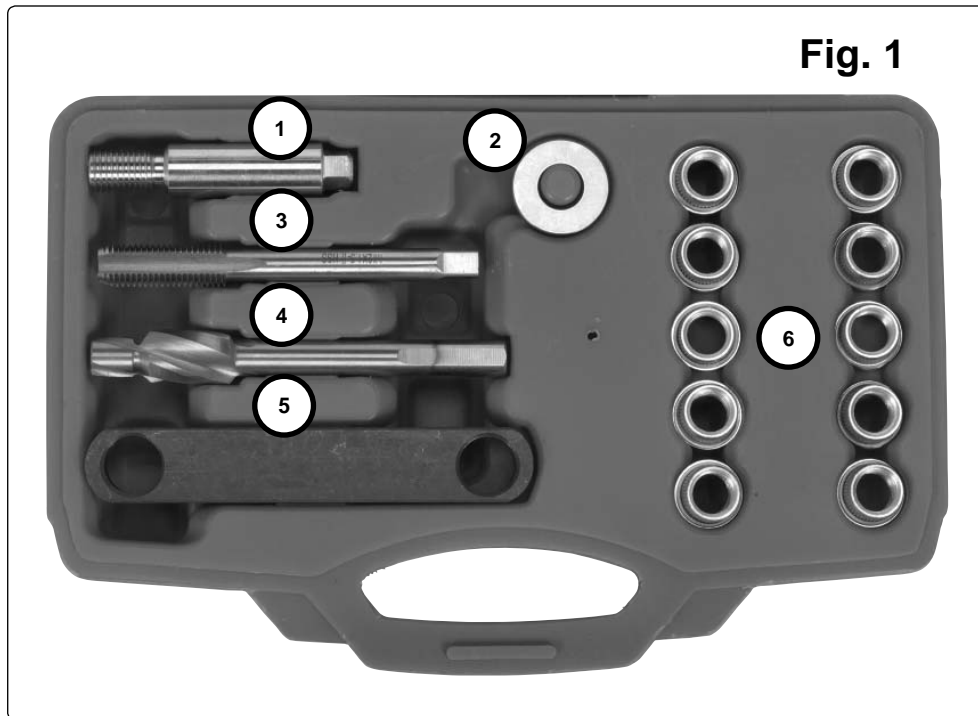

Ref	Description	Part Number
1	Insert Locator	VS0463.06
2	Washers and Roller Bearing	VS0463.05
3	M12 Tap	VS0463.04
4	Step Drill	VS0463.02
5	Alignment Plate	VS0463.01
6	Threaded Inserts (Replacment Insert - Pack of 10)	VS0463R

## 4. INSTRUCTIONS

- 4.1. Remove the road wheel, brake disc and brake calliper from the vehicle. Next remove the calliper mounting bracket, in some vehicles the calliper mounting bracket is a cast part of the hub.
- 4.2. Clean up the calliper mounting bracket and mount it in a vice.
- 4.3. **One Thread Stripped.**
  - 4.3.1. Clean the thread that is still intact using the M12 tap. Grease the tap for lubrication.
  - 4.3.2. Screw the insert locator (fig.1.1) into the good thread then slide the alignment plate over the locator. Using the other hole on the alignment plate as a guide, drill out the damaged thread using the stepped drill bit (fig.1.4). Continue drilling all the way through, using the larger diameter on the drill bit to enlarge the bolt hole so a threaded insert can be used.
  - 4.3.3. Take a threaded insert (fig.1.6) with copper washer and insert into drilled out hole. Ensure it is pushed in the opposite end that the bolt is inserted (fig.2A).

**Note:** Use some thread lock on the threaded insert.

  - 4.3.4. Slide the washers and roller bearing (fig.2C) over the calliper bolt then insert into the drilled out hole then screw into the new insert. Tighten the locator to seat the new insert fully home.
  - 4.3.5. Remove the bolts and reassemble the brake calliper onto the vehicle, refer to a proprietary manual for correct procedure.
- 4.4. **Both Threads Stripped.**
  - 4.4.1. When both threads are damaged use the stepped drill bit to centre on the first hole.
  - 4.4.2. Follow from 4.3.3 inserting a threaded insert.
  - 4.4.3. Then follow from section 4.3.2 for the second hole.

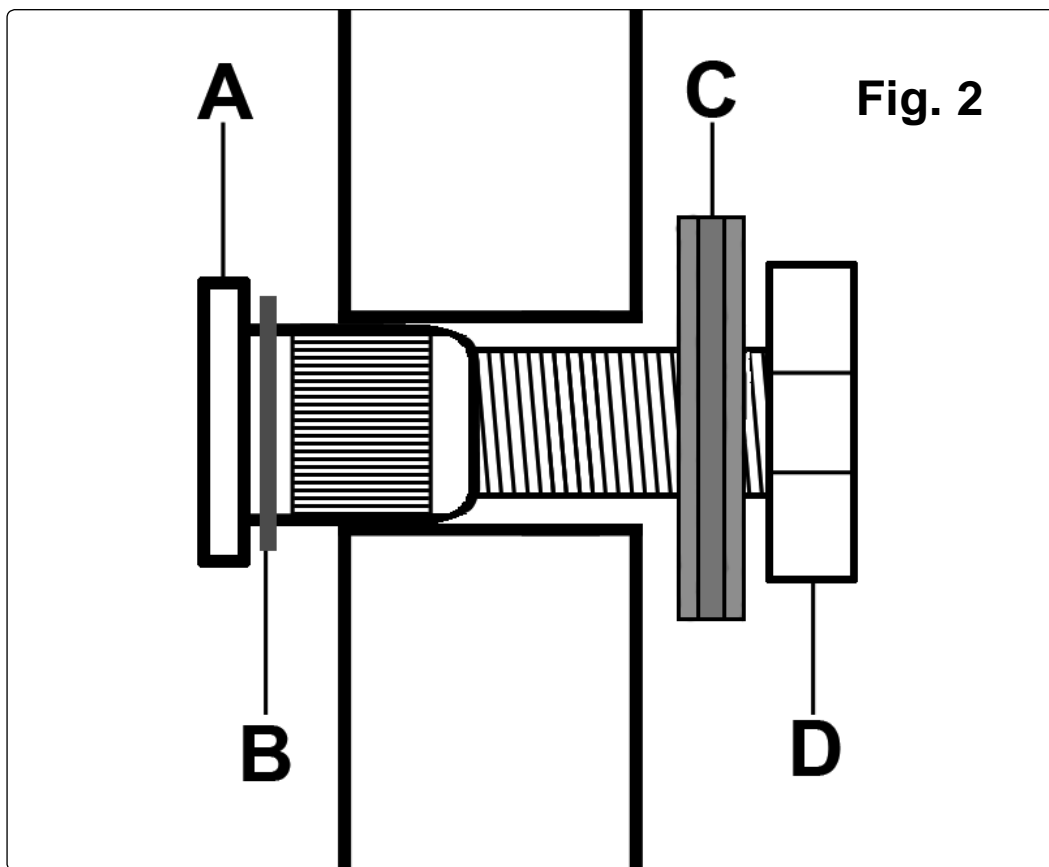

**NOTE:** It is our policy to continually improve products and as such we reserve the right to alter data, specifications and component parts without prior notice.

**IMPORTANT:** No liability is accepted for incorrect use of this product.

**WARRANTY:** Guarantee is 12 months from purchase date, proof of which will be required for any claim.



Sole UK Distributor, Sealey Group.  
Kempson Way, Suffolk Business Park,  
Bury St. Edmunds, Suffolk.  
IP32 7AR

01284 757500

01284 703534

[www.sealey.co.uk](http://www.sealey.co.uk)

[sales@sealey.co.uk](mailto:sales@sealey.co.uk)