

Thank you for purchasing a Sealey product. Manufactured to a high standard this product will, if used according to these instructions and properly maintained, give you years of trouble free performance.



IMPORTANT: PLEASE READ THESE INSTRUCTIONS CAREFULLY. NOTE THE SAFE OPERATIONAL REQUIREMENTS, WARNINGS AND CAUTIONS. USE THIS PRODUCT CORRECTLY, AND WITH CARE FOR THE PURPOSE FOR WHICH IT IS INTENDED. FAILURE TO DO SO MAY CAUSE DAMAGE AND/OR PERSONAL INJURY AND WILL INVALIDATE THE WARRANTY.

1. SAFETY INSTRUCTIONS

1.1. ELECTRICAL SAFETY.

WARNING! It is the responsibility of the owner and the operator to read, understand and comply with the following:

You must check all electrical products, before use, to ensure that they are safe. You must inspect power cables, plugs, sockets and any other connectors for wear or damage. You must ensure that the risk of electric shock is minimised by the installation of appropriate safety devices. A Residual Current Circuit Breaker (RCCB) should be incorporated in the main distribution board. We also recommend that a Residual Current Device (RCD) is used. It is particularly important to use an RCD with portable products that are plugged into a supply which is not protected by an RCCB. If in any doubt consult a qualified electrician. You may obtain a Residual Current Device by contacting your Sealey dealer.

You must also read and understand the following instructions concerning electrical safety.

- 1.1.1. The **Electricity at Work Act 1989** requires that all portable electrical appliances, if used on business premises, are tested by a qualified electrician, using a Portable Appliance Tester (PAT), at least once a year.
- 1.1.2. The **Health & Safety at Work Act 1974** makes owners of electrical appliances responsible for the safe condition of those appliances and the safety of the appliance operators. **If in any doubt about electrical safety, contact a qualified electrician.**
- 1.1.3. Ensure that the insulation on all cables and on the appliance is safe before connecting it to the power supply. See 1.1.1. and 1.1.2. and use a Portable Appliance Tester.
- 1.1.4. Ensure that cables are always protected against short circuit and overload.
- 1.1.5. Regularly inspect power supply cables and plugs for wear or damage and check all connections to ensure that none is loose.
- 1.1.6. **Important:** Ensure that the voltage marked on the appliance matches the power supply to be used and that the plug is fitted with the correct fuse - see fuse rating at right.
- 1.1.7. **DO NOT** pull or carry the appliance by the power cable.
- 1.1.8. **DO NOT** pull the plug from the socket by the cable.
- 1.1.9. **DO NOT** use worn or damaged cables, plugs or connectors.

Immediately have any faulty item repaired or replaced by a qualified electrician. When a BS 1363/A UK 3 pin plug is damaged, cut the cable just above the plug and **dispose of the plug safely.**

Fit a new plug according to the following instructions (UK only).

- a) Connect the **GREEN/YELLOW** earth wire to the earth terminal 'E'.
- b) Connect the **BROWN** live wire to the live terminal 'L'.
- c) Connect the **BLUE** neutral wire to the neutral terminal 'N'.
- d) **After wiring, check that there are no bare wires, that all wires have been correctly connected, that the cable outer insulation extends beyond the cable restraint and that the restraint is tight.**

Double insulated products, which are always marked with this symbol , are fitted with live (brown) and neutral (blue) wires only. To rewire, connect the wires as indicated above - **DO NOT** connect either wire to the earth terminal.

- 1.1.10. Products which require more than 13 amps are supplied without a plug. In this case you must contact a qualified electrician to ensure that a suitably rated supply is available. We recommend that you discuss the installation of an industrial round pin plug and socket with your electrician.
- 1.1.11. If an extension reel is used it should be fully unwound before connection. A reel with an RCD fitted is preferred since any appliance plugged into it will be protected. The cable core section is important and should be at least 1.5mm², but to be absolutely sure that the capacity of the reel is suitable for this product and for others which may be used in the other output sockets, we recommend the use of 2.5mm² section cable.

1.2. GENERAL SAFETY.

- WARNING!** Ensure Health and Safety, local authority and general workshop practice regulations are adhered to when using this unit.
- IMPORTANT:** If possible, refer to the vehicle manufacturer's service instructions to establish the correct procedure.
- Maintain this product in good working order and condition, take immediate action to repair or replace damaged parts.
- Use approved parts only. Unapproved parts may be dangerous and will invalidate the warranty.
- WARNING!** Brake fluid is hazardous, wear approved eye protection and keep skin contact to a minimum. If brake fluid enters eyes, rinse immediately with plenty of water and seek medical advice. If swallowed seek medical advice immediately.
- WARNING!** Only use new brake fluid, used brake fluid or other fluids will contaminate the system and possible brake system failure may result.
- WARNING!** Brake fluid is flammable - keep away from sources of ignition, including hot surfaces e.g. exhaust manifold.
- WARNING!** Brake fluid will damage paintwork and clothing. Any spillages should be flushed with water immediately.
- DO NOT** use to perform a task for which it is not designed.
- DO NOT** allow untrained persons to use the unit.
- DO NOT** use when tired or under the influence of drugs, alcohol or intoxicating medication.
- WARNING! DO NOT** pollute the environment by allowing uncontrolled discharge of fluids.
- Keep children and unauthorised persons away from the work area.
- Keep work area clean and tidy and free from unrelated materials.
- Ensure the work area has adequate lighting.
- Ensure that a vehicle which has been jacked up and had its wheels removed, is adequately supported with axle stands.

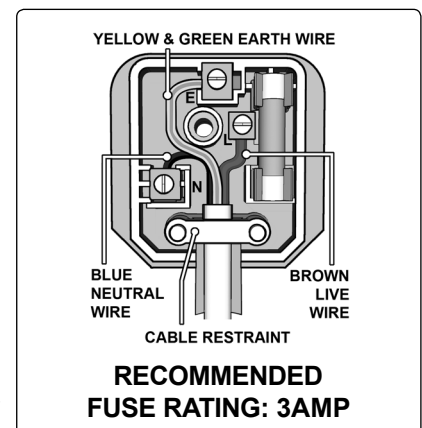

- x **DO NOT** disconnect universal adaptor from brake fluid reservoir until the unit has been de-pressurised.
- ✓ Dispose of waste brake fluid in accordance with local authority regulations.
- ✓ Always read and comply with the warnings on the brake fluid container.
- ✓ Wear suitable clothing to avoid snagging.
- x **DO NOT** wear jewellery, and tie back long hair. A full range of personal safety equipment is available from your Sealey dealer.
- ✓ When not in use, clean unit and store in a safe, dry, childproof location.

2. INTRODUCTION & SPECIFICATION

One-man brake bleeding made easy. Ideal for use on the vehicle lift, as unit maintains system pressure using electric pump to drive clean fluid through a long high pressure hose to the reservoir – enables quick, 'walk-around' brake bleeding. High pressure system feeds fluid at up to 5.8bar making it particularly suitable for modern brake systems found on many vehicles including Audi, BMW and Mercedes. Features thermal control of pump for long and reliable pump life. Includes Ø42mm reservoir adaptor and accepts many types of brake fluid containers up to 10ltrs.

Model No: VS0206.V2
Power Supply: 230V
Maximum Pressure: 5.8Bar
Weight:10kg

Accessories:

- 1 litre Bleed Bottle and Pipe
- 3 Rubber Adaptors for Brake Fluid Containers
- 1 Universal Adaptor for Brake Master Cylinder

Use brake fluid to the vehicle manufacturer's specifications:

Type:	Boiling Temp:	Viscosity at -40°C/+100°C
DOT 3	205-230°C	1450/2
DOT 4	250-268°C	1480/2.3
DOT 5.1	260-275°C	800/1.8
DOT 6.1	300-315°C	N/A

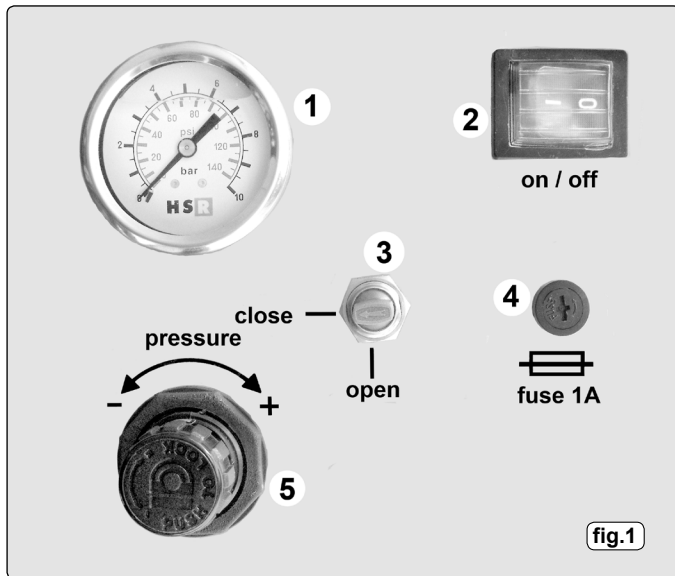

3. OPERATION

WARNING! Familiarise yourself with the hazards of brake fluid - read the manufacturer's instructions on the container.

3.1. Preparing unit for use.

- 3.1.1. Before using on a vehicle for the first time, it is necessary to bleed all air out of the unit's system. Ensure that the pressure relief valve (fig.1.3) is closed and that the pressure knob (fig.1.5) is fully off (anti-clockwise).
- 3.1.2. Insert the suction pipe into a suitable container of clean brake fluid (which should be mounted in the recess in the back of the unit) using one of the rubber conical adaptors. Make sure the pipe reaches the bottom of the container.
- 3.1.3. Attach the universal adaptor to the pressure delivery hose's quick-fit coupling, and place over a suitable container for recovering brake fluid.
- 3.1.4. Plug the machine into a suitable mains electrical supply and turn on the unit at the switch (fig.1.2), as brake fluid is drawn through the unit, air will be expelled from the system. The pressure may need to be increased slightly by turning the pressure knob clockwise. When fluid without any air bubbles present, flows from the delivery hose, turn the unit off. Open the pressure release valve (fig.1.3) to depressurise the unit, ensure the pressure gauge (fig.1.1) returns to zero, before closing the valve. Disconnect the pressure delivery hose from the adaptor by releasing the quick-fit coupling. Turn the pressure knob fully off (anti-clockwise) if it was adjusted during the operation.
- 3.1.5. Leave the suction pipe connected to the container of clean brake fluid. The unit is now ready to use

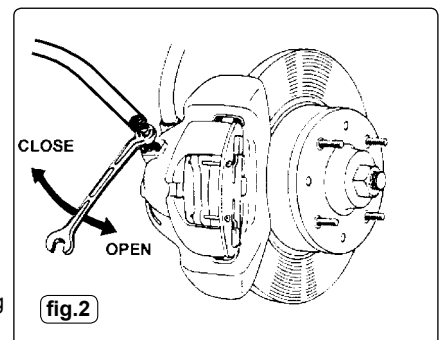

NOTE: The thermal cut out will operate at around 15 minutes of continuous use, so will not be suitable for vehicle systems that require prolonged diagnostics to bleed the braking system. The thermal cut-out is a safety feature designed to protect and prolong the life of the pump.

3.2. Brake bleeding procedure.

DO NOT touch the vehicle's brake pedal whilst bleeding the brakes.

Refer to the vehicle manufacturer's instructions for brake bleeding and wheel sequence before proceeding. If no specific instructions from the vehicle manufacturer exist, follow the instructions detailed below. If the manufacturer has not supplied a specific figure for the maximum pressure for this operation, it is advised to keep the pressure within the 1.5 to 2Bar range, to avoid damaging the brake fluid reservoir etc.

Fully prepare the vehicle by jacking it up or by using a ramp, remove the wheels from the vehicle as required to gain access, so that work can commence as soon as the unit is turned on.

- 3.2.1. Remove the cap on the vehicle's brake fluid reservoir. If the brake fluid level is not at its maximum level, top it up. Fit the universal adaptor to the brake fluid reservoir, tighten it and ensure that there is a good seal.
- 3.2.2. Connect the pressure delivery hose's quick connector to the universal adaptor.
- 3.2.3. Ensure that the pressure knob on the unit is fully off (anti-clockwise) and switch on the unit. Adjust the pressure to the required setting by turning the pressure knob clockwise.
- 3.2.4. Starting with the wheel furthest away from the brake fluid reservoir, connect one end of the tube from the bleed bottle to the brake nipple and, using a brake spanner, open the nipple approximately ¼ turn (fig.2), brake fluid will flow through the clear pipe into the bottle, when there are no visible bubbles in the fluid, tighten the bleed nipple and remove the pipe, taking care not to spill any brake fluid.
- 3.2.5. Repeat the procedure at each location in turn, as required.
- 3.2.6. When finished, turn the unit off. Open the pressure release valve to depressurise the unit, allow the pressure gauge to return to zero. **DO NOT** attempt to remove the adaptor from the vehicle's brake fluid reservoir, until the unit is de-pressurised. Close the pressure release valve and turn the pressure knob fully off (anti-clockwise).
- 3.2.7. Disconnect the pressure delivery hose from the adaptor by releasing the quick-fit coupling. Take care not to spill any brake fluid and then remove the adaptor from the brake fluid reservoir. Check the level of the brake fluid in the reservoir, any excess fluid should be removed, or top it up if necessary.
- 3.2.8. Refit the vehicle's brake fluid reservoir cap.

3.3. Changing the brake fluid.

- 3.3.1. Carry out the brake bleeding procedure as described in 3.2.
- 3.3.2. Allow a longer period of time when bleeding, to allow the new fluid to flush out the old fluid. When new fluid can be seen in the clear tube, tighten the brake nipple.
- 3.3.3. Repeat this procedure at each wheel in turn.
- 3.3.4. Disconnect as above (3.2.6. to 3.2.8.).

NOTE: When brake bleeding and/or brake fluid changing is complete, test the action of the brake pedal to ensure that the brakes are working correctly and are not spongy, before taking the vehicle onto the road.

3.4. Clutch bleeding procedure.

- 3.4.1. Refer to the relevant vehicle manufacturer's instructions for clutch bleeding procedure. If no specific instructions from the vehicle manufacturer exist, the same basic procedures as for brake bleeding can be followed. Dispose of all waste brake fluid responsibly. Contact your local authority for details.

4. MAINTENANCE

- 4.1. If the unit is not to be used for a long period, carefully remove suction pipe from the brake fluid container, wipe the pipe clean. Wipe unit clean with a dampened cloth, before storing it away in a safe, dry, childproof location.
- 4.2. Should the unit stop working, first check the internal 1A fuse (fig.1.4) to see if it has blown.
- 4.3. There are no regularly servicable parts to the unit, it should be returned to an authorised Sealey agent for repair if needed.

Environmental Protection.



Recycle unwanted materials instead of disposing of them as waste. All tools, accessories and packaging should be sorted, taken to a recycle centre and disposed of in a manner which is compatible with the environment.



WEEE Regulations.

Dispose of this product at the end of its working life in compliance with the EU Directive on Waste Electrical and Electronic Equipment. When the product is no longer required, it must be disposed of in an environmentally protective way. Contact your local solid waste authority for recycling information.

Parts support is available for this product. To obtain a parts listing and/or diagram, please log on to www.sealey.co.uk, email sales@sealey.co.uk or phone 01284 757500.

NOTE: It is our policy to continually improve products and as such we reserve the right to alter data, specifications and component parts without prior notice.

IMPORTANT: No liability is accepted for incorrect use of this product.

WARRANTY: Guarantee is 12 months from purchase date, proof of which will be required for any claim.

INFORMATION: For a copy of our latest catalogue and promotions call us on 01284 757525 and leave your full name and address, including postcode.



Sole UK Distributor, Sealey Group,
Kempson Way, Suffolk Business
Park, Bury St. Edmunds, Suffolk,
IP32 7AR

01284 757500

01284 703534



www.sealey.co.uk



sales@sealey.co.uk