

Thank you for purchasing a Sealey product. Manufactured to a high standard this product will, if used according to these instructions and properly maintained, give you years of trouble free performance.

IMPORTANT: PLEASE READ THESE INSTRUCTIONS CAREFULLY. NOTE THE SAFE OPERATIONAL REQUIREMENTS, WARNINGS AND CAUTIONS. USE THIS PRODUCT CORRECTLY, AND WITH CARE FOR THE PURPOSE FOR WHICH IT IS INTENDED. FAILURE TO DO SO MAY CAUSE DAMAGE AND/OR PERSONAL INJURY AND WILL INVALIDATE THE WARRANTY. PLEASE KEEP INSTRUCTIONS SAFE FOR FUTURE USE.

1. SAFETY INSTRUCTIONS

- ✓ Keep this product in good working order and condition, take immediate action to repair or replace damaged parts.
- ✓ Use approved parts only. Unapproved parts may be dangerous and will invalidate the warranty.
- ✓ Keep children and unauthorised persons away from the work area.
- ✓ Keep work area clean and tidy and free from unrelated materials.
- ✓ Ensure the work area has adequate lighting.
- ✗ **DO NOT** use the kit to perform a task for which it is not designed.
- ✗ **DO NOT** allow untrained persons to use the kit.
- ✗ **DO NOT** use when tired or under the influence of drugs, alcohol or intoxicating medication.
- ✓ After use, clean equipment and store in a cool, dry, childproof area.
- ✓ Dispose of waste liquids in accordance with local authority regulations.
- ✓ Always read and comply with the warnings on the brake fluid container.
- ✓ Wear eye protection and keep skin contact to a minimum. If brake fluid enters eyes rinse with plenty of water and seek medical advice. If swallowed seek medical advice immediately.
- ☐ **WARNING!** Only use new Brake Fluid, used Brake Fluid or other fluids will contaminate the system and possible brake system failure may result.
- ☐ **WARNING! DO NOT** pollute the environment by allowing uncontrolled discharge of fluids.
- ☐ **WARNING!** Brake fluid is flammable - keep away from sources of ignition, including hot surfaces e.g. exhaust manifold.
- ☐ **WARNING!** Brake fluid will damage paintwork. Any spillage should be flushed with water immediately.
- ☐ **WARNING!** Do not allow the fluid capacity in the unit to fall below ½ litre during the bleeding process otherwise air may enter the system.

2. INTRODUCTION & SPECIFICATION

One-man pressure brake and clutch bleeding system suitable for the professional workshop. Low pressure tank (20-40psi) can be pre-charged with compressed air - making the unit fully portable. Large reservoir means reduced risk of running the system dry during bleeding process or complete fluid change. Suitable for use on ABS systems. Features a long delivery hose for operation with a low level ramp and long reach handle for easy mobility. Supplied with a range of European, Japanese and US vehicle adaptors.

Model No:	VS0204.V3
Air Supply:	20 - 40psi
Air consumption:	4.5cfm
Inlet size:	1/4" BSP
Tank capacity:	6.0 litres
Hose Length:	3mtr

Accessories

2 x	1 litre Bleed Bottles
8 x	Manufacturer Adaptors
3 x	Universal Adaptors
2 x	Threaded Cable & Wing Nuts
2 x	Clamp Brackets
1 x	Rubber Squeeze
1 x	Carry Case

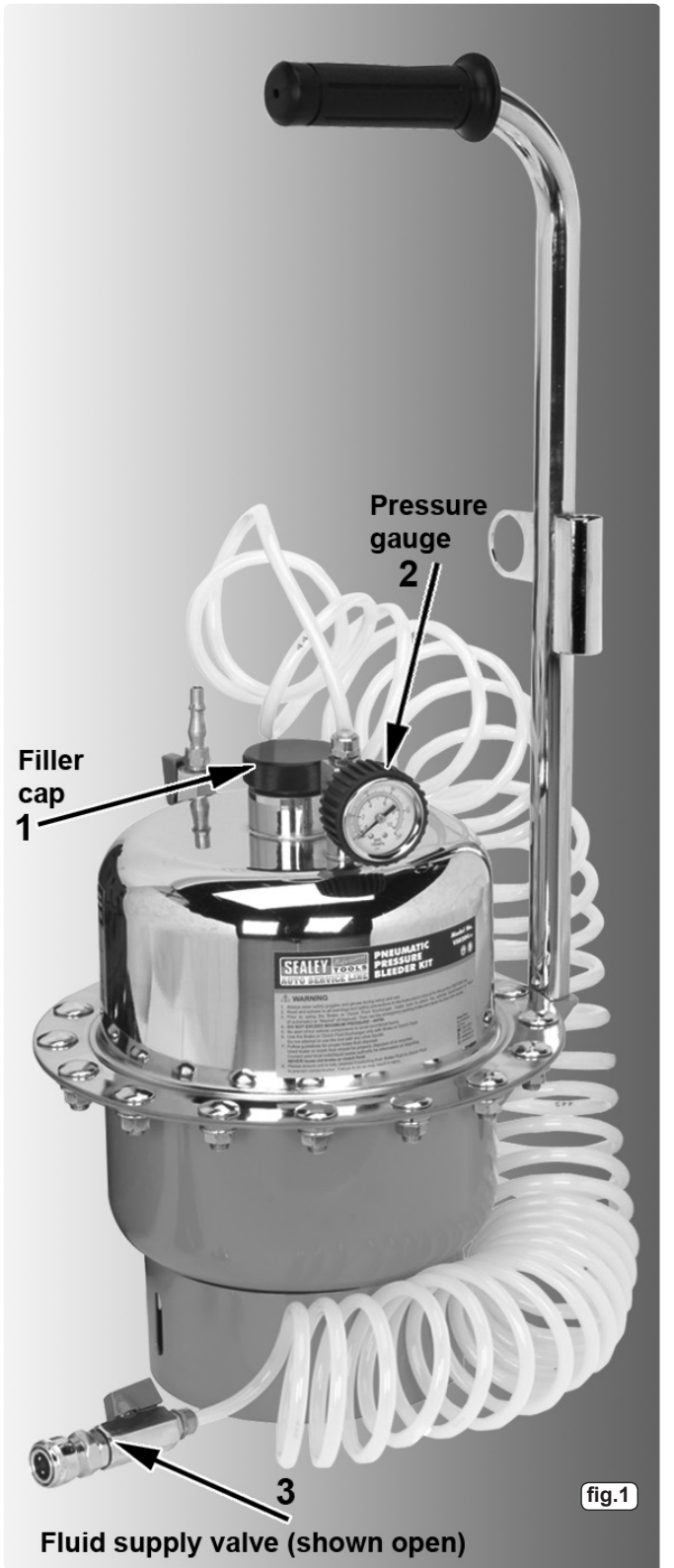

3. AIR SUPPLY CONNECTION

Recommended hook up is shown in fig.2.

- 3.1. You will require an air pressure of 40psi and air flow according to specification.
- 3.2. Ensure that the air supply is clean and does not exceed 40psi. Too high a pressure and/or unclean air may damage the diaphragm and will shorten the product life due to excessive wear and may cause damage and/or personal injury.
- 3.3. Drain the air tank daily. Water in the air line will damage the unit and invalidate your warranty.
- 3.4. The minimum hose diameter should be ¼" I.D and fittings must have the same internal dimensions.
- 3.5. Keep hose away from Heat, oil and sharp edges. Check hoses for wear and make certain that all connections are secure.

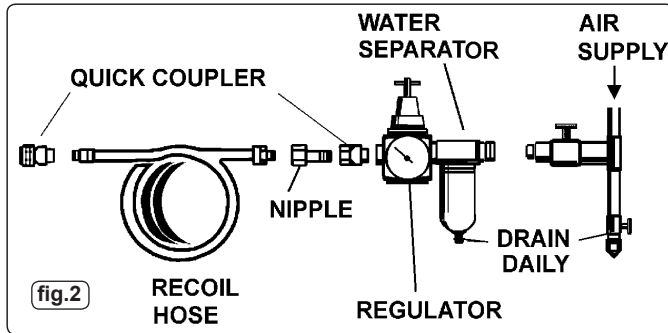

4. OPERATION

- 4.1. **Brake bleeding procedure.**
Refer to the vehicle manufacturer's instructions for brake bleeding and wheel sequence before proceeding. If no specific instructions from the vehicle manufacturer exist, follow the instructions detailed below.
 - ❑ **WARNING! Familiarise yourself with the hazards of brake fluid - read manufacturer's instructions on the container. Do not touch the vehicle's brake pedal whilst bleeding the brakes.**
- 4.1.1. Check that the pressure release valve (fig.3.1) is open and that there is no pressure within the unit. Unscrew the filler cap (fig.1.1) on the unit and **top up to full capacity** with new brake fluid. Replace filler cap and close the pressure release valve.
- ❑ **WARNING! Do not allow the fluid capacity within the unit to fall below ½ litre during the bleeding process otherwise air may enter the system.**
NOTE: The diaphragm may be visible from the neck of the filler and will require deflating before filling, this can be done by pushing down on the diaphragm with a clean blunt instrument.
- 4.1.2. Check that the air regulator (fig.3.2) is turned fully counter clockwise, the air supply valve (fig.3.3) and the fluid supply pipe valve (fig.1.3) are in the closed positions.
- 4.1.3. Connect the brake bleeder (fig.3.4) to a suitable compressed air supply.
- 4.1.4. Slowly open the air supply valve (fig.3.3) and turn the air regulator clockwise until a pressure of 20psi is registered on the pressure gauge (fig1.2).
NOTE: The brake bleeder can be used remotely by closing the air supply valve once the unit has been charged with air and then disconnect the air supply.
DO NOT exceed the maximum pressure of 40psi, if the unit exceeds this pressure the safety valve (fig.3.5) will be activated.
- 4.1.5. Connect one of the adaptors to the end of the fluid supply pipe and hold over a waste oil container, slowly open the valve (fig.1.3) to release air from the supply pipe. When brake fluid is free flowing, close the valve.
- 4.1.6. Remove the cap on the vehicle's brake fluid reservoir. If the brake fluid level is not at maximum, top it up and select a suitable adaptor for the vehicle. In some cases a universal adaptor (D1, D2 or E1) will be required, see section 4.4. Tighten the adaptor onto the master cylinder ensuring that a good seal is achieved (fig.4).
- 4.1.7. Connect the fluid supply pipe quick connector to the adaptor and slowly open the valve (fig.1.3) to pressurise the system.

- 4.1.8. Starting with the brake furthest away from the master cylinder connect the tube from the bleeding bottle to the nipple and using a brake spanner open the nipple approximately ¼ turn (fig.5), brake fluid will flow through the clear pipe into the bottle, when there are no visible bubbles tighten the bleed nipple.
- 4.1.9. Repeat the process at each wheel in turn as necessary.
- 4.1.10. To remove the brake bleeder, shut off the fluid supply pipe valve (fig.1.3), close the air supply valve (fig.3.3) and open the pressure release valve to depressurise the unit.
- 4.1.11. Disconnect the fluid supply pipe from the adaptor, taking care not to spill any brake fluid and remove the adaptor from the brake fluid reservoir. Any excess fluid in the reservoir should be removed using the supplied rubber squeeze and disposed of into a suitable waste oil container.
- 4.1.12. Refit the original brake fluid reservoir cap.
- 4.2. **Changing the brake fluid.**
 - 4.2.1. Carry out the brake bleeding procedure as described above.
 - 4.2.2. When new fluid can be seen in the clear tube tighten the brake nipple.
 - 4.2.3. Repeat this procedure at each wheel in turn.
 - 4.2.4. Disconnect as above (4.1.10 & 4.1.11).
NOTE: When brake bleeding and/or fluid changing is complete, test the action of the brake pedal to ensure that the brakes are working and are not spongy before using the vehicle on the road.
- 4.3. **Clutch bleeding procedure.**
Refer to the relevant vehicle manufacturer's instructions for clutch bleeding procedure. If no specific instructions from the vehicle manufacturer exist, the same procedures as for brake bleeding should be followed.

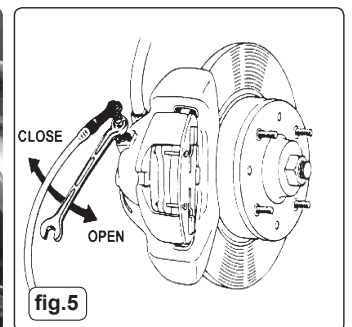
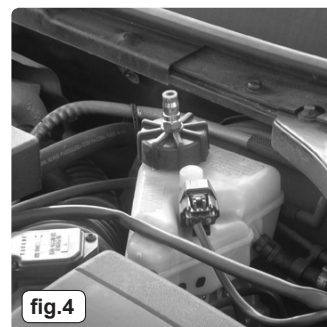
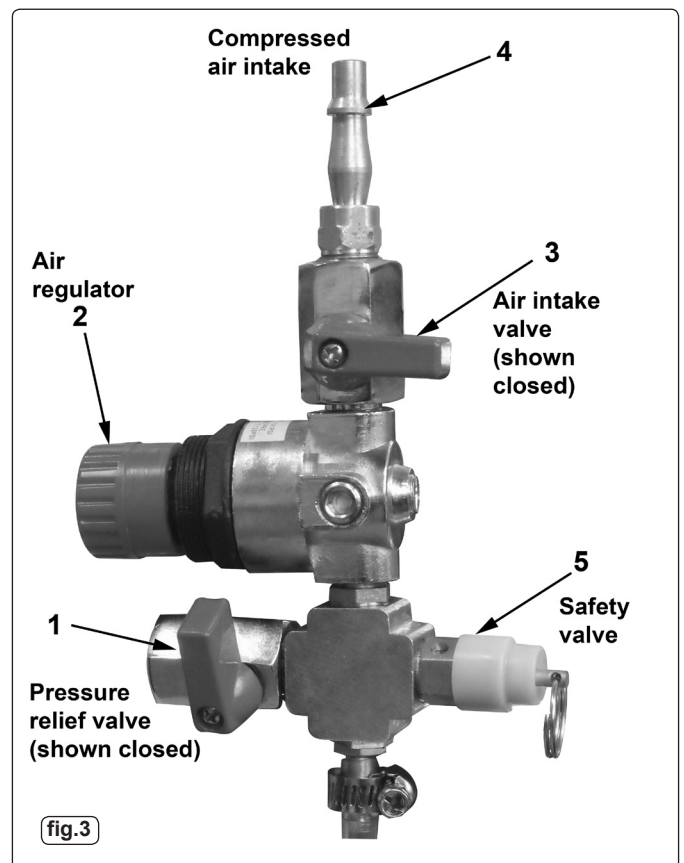

4.4. Universal adaptors. (D1, D2 & E1)

- 4.4.1. Adaptor D2 can be fitted using clamp F1 and one of the double ended threaded cables. Wrap the cable around the brake or clutch master cylinder and locate through the two holes in the adaptor and the two slots in the clamp, take out the slack in the cable using the wing nuts and then tighten the clamp to seal the adaptor to the master cylinder (fig.6).
- 4.4.2. Apply the same procedure to adaptor D1 and clamp F2 (fig.7).
- 4.4.3. The E1 adaptor is attached by using the two metal support clamps and the two threaded cables, tighten the four wing nuts evenly to apply enough pressure to seal the adaptor to the master cylinder (fig.8).

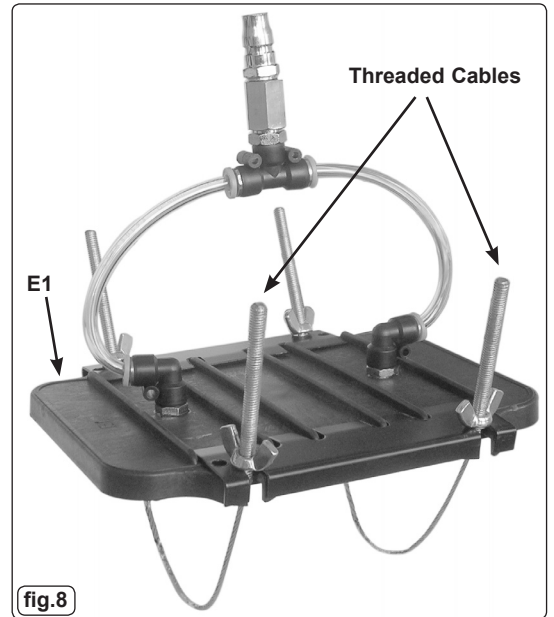
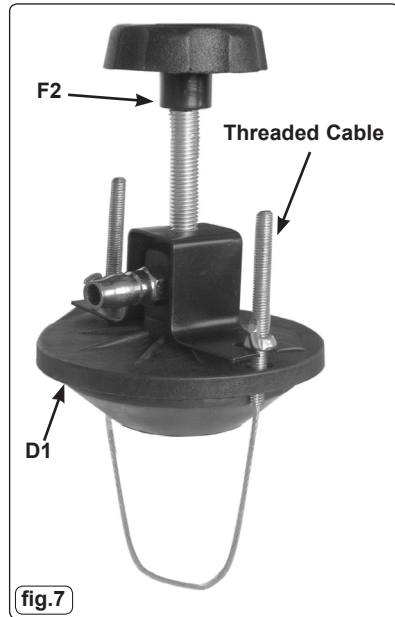
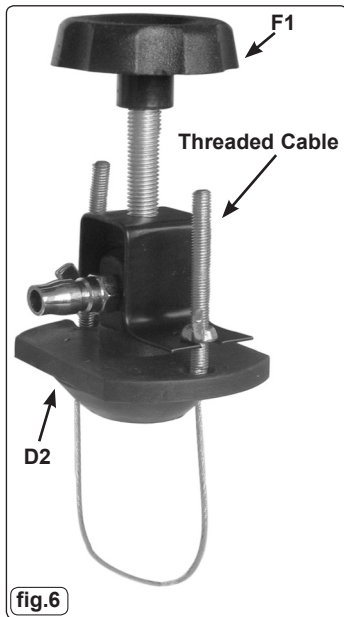

5. CLEANING & MAINTENANCE

- 5.1. Ensure that the unit is depressurised before carrying out any maintenance and drain all fluids from the main tank and from the fluid supply tube.
- 5.2. Clean up any spilled brake fluid and wipe down with a clean cloth.
- 5.3. Store in a clean, dry and childproof location.



Accessories

- 2 x 1 litre Bleed Bottles
- 8 x Manufacturer Adaptors
- 3 x Universal Adaptors
- 2 x Threaded Cable & Wing Nuts
- 2 x Clamp Brackets
- 1 x Rubber Squeeze
- 1 x Carry Case

Parts support is available for this product. To obtain a parts listing and/or diagram, please log on to www.sealey.co.uk, email sales@sealey.co.uk or phone 01284 757500.

NOTE: It is our policy to continually improve products and as such we reserve the right to alter data, specifications and component parts without prior notice.
IMPORTANT: No liability is accepted for incorrect use of this product.
WARRANTY: Guarantee is 12 months from purchase date, proof of which will be required for any claim.
INFORMATION: For a copy of our catalogue and latest promotions call us on 01284 757525 and leave your full name, address and postcode.



Sole UK Distributor
Sealey Group,
 Bury St. Edmunds,
 Suffolk.

☎ 01284 757500
 📠 01284 703534

www.sealey.co.uk
sales@sealey.co.uk