

*Thank you for purchasing a Sealey Product. Manufactured to a high standard this product will, if used according to these instructions and properly maintained, give you years of trouble free performance.*



**IMPORTANT: PLEASE READ THESE INSTRUCTIONS CAREFULLY. NOTE THE SAFE OPERATIONAL REQUIREMENTS, WARNINGS AND CAUTIONS. USE THIS PRODUCT CORRECTLY AND WITH CARE FOR THE PURPOSE FOR WHICH IT IS INTENDED. FAILURE TO DO SO MAY CAUSE DAMAGE AND/OR PERSONAL INJURY AND WILL INVALIDATE THE WARRANTY. PLEASE KEEP INSTRUCTIONS SAFE FOR FUTURE USE.**

## 1. SAFETY INSTRUCTIONS

- ✓ Follow workshop Health & Safety rules, regulations and conditions when using this equipment.
- ❑ **WARNING!** Disconnect from air supply before changing accessories or servicing.
- ✓ Maintain the equipment in good condition and replace any damaged or worn parts. *Use genuine parts only. Unauthorised parts may be dangerous and will invalidate the warranty.*
- ❑ **WARNING!** Check that correct air pressure is maintained and DOES NOT exceed 100psi.
- ✓ Keep air hose away from heat, oil and sharp edges. Check air hose for wear before each use and ensure that all connections are secure.
- ✓ Wear approved safety gloves and eye and ear protection.
- ✓ Keep gun clean and in good working order for best and safest performance.
- ✓ Keep children and unauthorised persons away from the work area.
- ✗ **DO NOT** use the gun for a task it is not designed to perform.
- ❑ **WARNING! DO NOT** use gun if damaged or thought to be faulty. Contact your local service agent.
- ✗ **DO NOT** drop, throw or abuse the gun.
- ✗ **DO NOT** carry the gun by the air hose, or yank the hose from the air supply.
- ✗ **DO NOT** operate the gun if you are tired or under the influence of alcohol, drugs or intoxicating medication.
- ✗ **DO NOT** direct air from the air hose at yourself or others.
- ✓ When not in use disconnect from air supply and store in a safe, dry, childproof location.

## 2. INTRODUCTION & SPECIFICATION

Eliminates the introduction of bubbles and air-locks into the cooling system and dramatically reduces system filling time. No more time-consuming system bleeding. Reduces fluid waste and messy spills. Automatically conducts system leak test. Two adaptors cover most radiators and header tanks, including those of commercial vehicles. Simple operation requires workshop air supply and does not require fiddly interchange of vacuum and fluid hoses - as found on other versions of this tool. Supplied with 1.5mtr of fluid hose.

Air Pressure (max) . . . . . 90psi (6.21 bar)  
 Air Pressure (min) . . . . . 80psi (5.55 bar)  
 Air Consumption (max @ 90psi) . . . 180ltr/min(10cfm)  
 Air Connection . . . . . 1/4" BSP  
 Filling Hose Length . . . . . 1500mm



## 3. AIR SUPPLY

Recommended hook-up is shown in fig. 1.

- 3.1. Ensure that the trigger is in the 'Off' position (out) when connecting the air supply.
- ❑ **WARNING!** Ensure that the air supply is clean and does not exceed 100psi. Too high an air pressure or unclean air will shorten the life of the gun, due to excessive wear, and may be dangerous, causing damage and/or personal injury.
- 3.2. Drain the air tank daily.
- 3.3. Clean compressor air inlet filter weekly.
- 3.4. Line pressure should be increased to compensate for unusually long air hoses (over 8 meters). The minimum hose size should be 1/4" I.D. and fittings must have the same internal bore.
- 3.5. Keep hose away from heat, oil and sharp edges. Check hose for wear and make certain that all connections are secure.

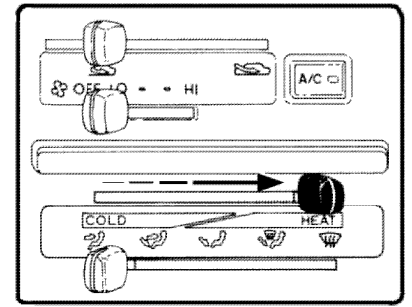
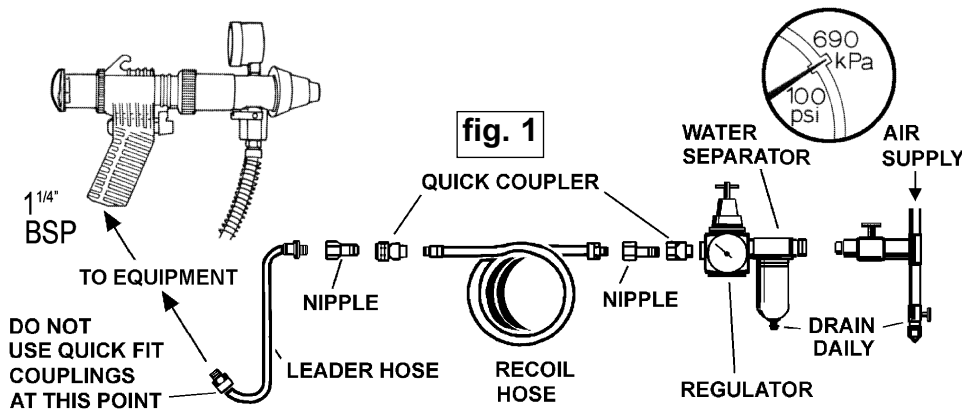

## 4. OPERATING INSTRUCTIONS

**WARNING!** Ensure you read, understand and apply safety instructions before use.

### 4.1. Preparation

4.1.1. Set vehicle heater control to 'On' and/or 'Hot'. (fig.2)

4.1.2. Drain and flush coolant system. (fig.3)

4.1.3. Inspect all coolant system components and repair/replace any unserviceable items.

4.1.4. Prepare a suitable coolant mix (see vehicle handbook). Mix 10% more than the system volume to ensure that the filler hose will always be submerged. (fig.4)

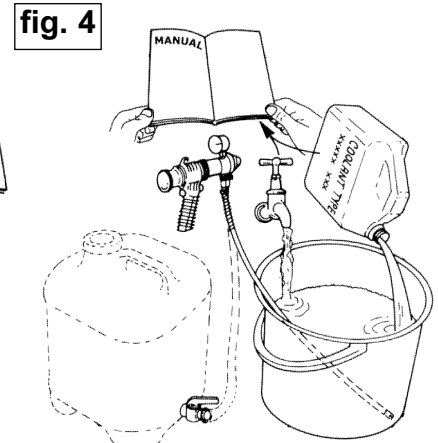
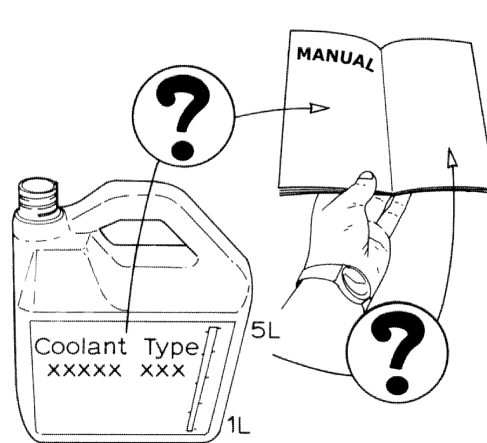
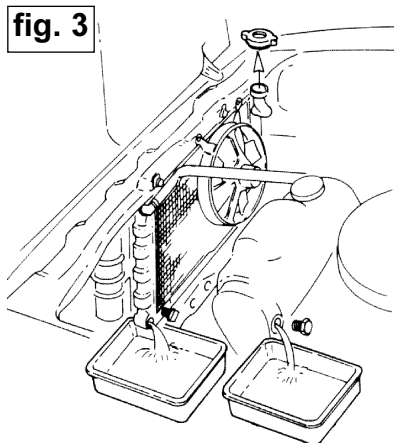

4.1.5. Connect the gun to the air system, as described in Section 3.

### 4.2. Suction Filling

4.2.1. Raise the container of coolant, level with the fill point. Insert the multi-fit rubber cone (on the gun) into the filler neck of the radiator (or header tank, if fitted). Support the air line so that the gun is not pulled off centre.

NOTE: On some vehicles fitted with an overflow tank, it may be necessary to clamp the overflow hose. (fig.5)

4.2.2. Place the filler hose into the container of coolant. Ensure that the end of the hose remains submerged throughout the filling process.

4.2.3. Check that the tap on the gun is in the 'Vac' position (fig.6) and then press and lock (by turning slightly) the trigger. (fig.7)

NOTE: Hoses will collapse under the vacuum being generated - this is normal.

4.2.4. Allow the air to evacuate until the needle reads in the green. (fig.7)

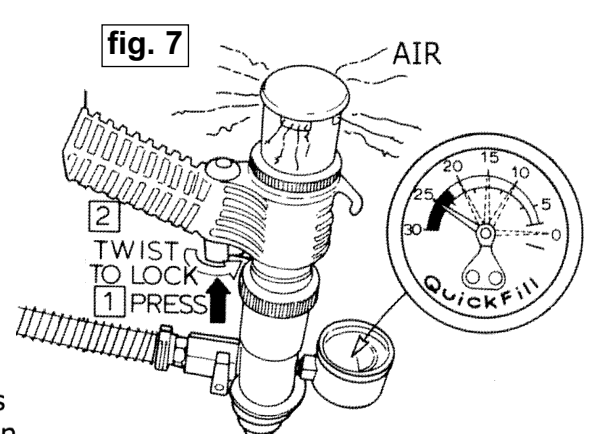
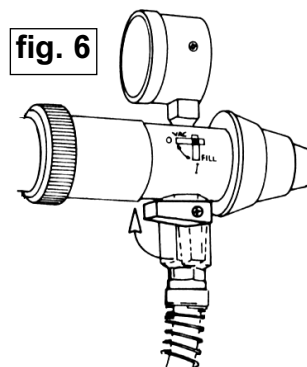
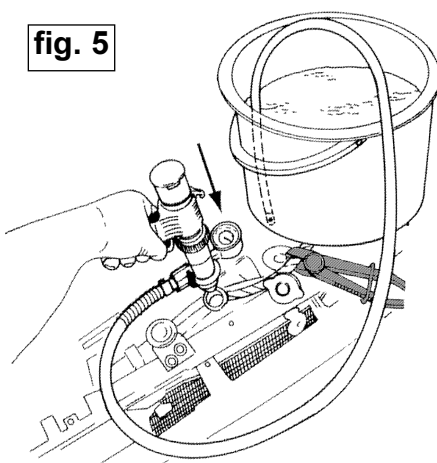

**!** Ensure fill tap is in "VAC" position

- 4.2.5. When the gauge is reading in the green sector and has stopped rising release the gun trigger (fig.8) and check the gauge over the next 3 minutes (fig.9). If the gauge reading drops there is a system leak which will require locating and rectifying before proceeding further.
- 4.2.6. Apply a downward force during filling. Turn the tap fully to the 'Fill - I' position (fig.10) and coolant will flow into the cooling system. For best results raise the coolant container above the level of the filler neck.

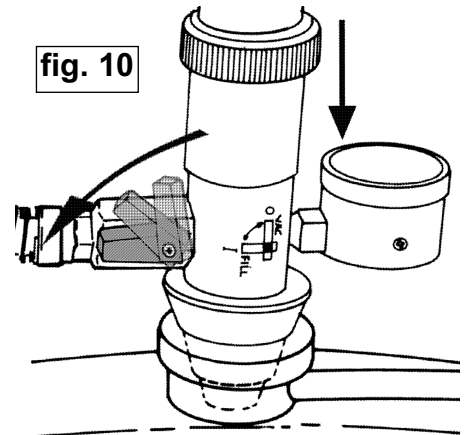
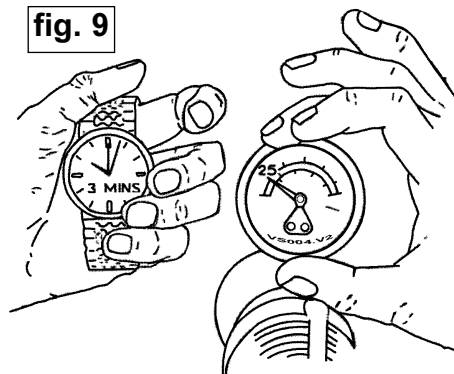

4.2.7. When the gauge reads '0' turn the fill tap to the 'VAC' position ( fig.11) and remove the gun from the filler neck. If necessary top up the coolant to the specified level and refit the pressure cap. The system is filled and free from air locks.

4.2.8. Start the engine and run until normal operating temperature is reached (fig.12). Allow to cool and top up coolant if necessary (fig.13).

4.2.9. It is advisable to now pressure test the system and to check the operation of the thermostat and cooling fan(s).

**NOTE:** To prevent internal valves of unit from sticking, wash out with water after each use (fig.14).

When not in use, disconnect from air supply, clean and store in a safe, dry, childproof location.

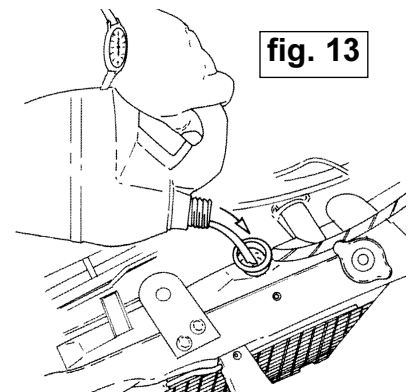
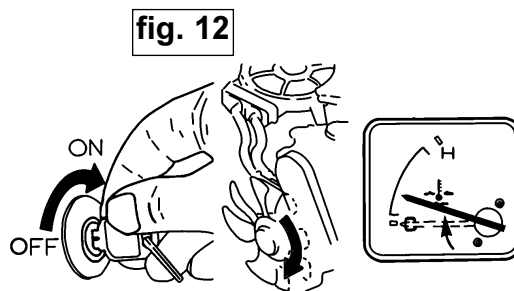
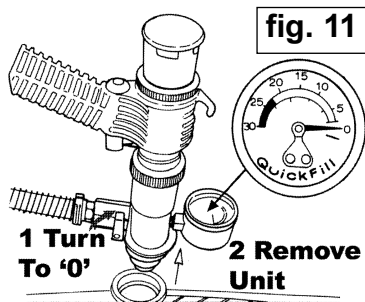

## 5. MAINTENANCE

**WARNING!** Disconnect gun from air supply before changing accessories, servicing or performing maintenance. Replace or repair damaged parts. Use genuine parts only. Unapproved parts may be dangerous and will invalidate the warranty.

Air supply faults may cause loss of power or erratic action. Reduced compressor output, excessive drain on the air line, moisture or restrictions in air pipes or the use of hose connections of improper size may reduce air supply.

To prevent internal valves of unit from sticking, wash out with water after each use.

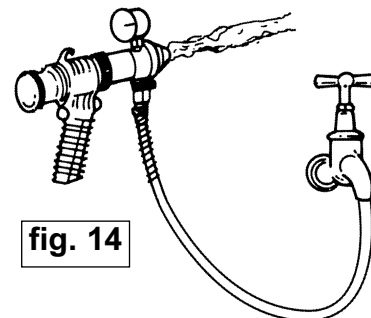

## 6. DECLARATION OF CONFORMITY

# Declaration of Conformity



We, the sole importer into the UK, declare that the product listed here is in conformity with the following standards and directives. The construction file for this product is held by the Manufacturer and may be inspected, by a national authority, upon request to Jack Sealey Ltd.

**FAST FILL COOLANT GUN**  
**Model: VS004.V2**

97/23/EC Pressure Equipment Directive  
93/68/EEC Marking Directive

Signed by Mark Sweetman  
10th April 2005

For Jack Sealey Ltd. Sole importer into the UK of  
Sealey Professional Tools.

NOTE: It is our policy to continually improve products and as such we reserve the right to alter data, specifications and component parts without prior notice.  
IMPORTANT: No liability is accepted for incorrect use of this equipment.  
WARRANTY: Guarantee is 12 months from purchase date, proof of which will be required for any claim.  
INFORMATION: For a copy of our latest catalogue and promotions call us on 01284 757525 and leave your full name and address, including postcode.



Sole UK Distributor  
Sealey Group,  
Bury St. Edmunds, Suffolk.

01284 757500  
01284 703534

www.sealey.co.uk  
sales@sealey.co.uk

PARTS FOR:

**FAST FILL COOLANT GUN**

Model No: **VS004.V2**

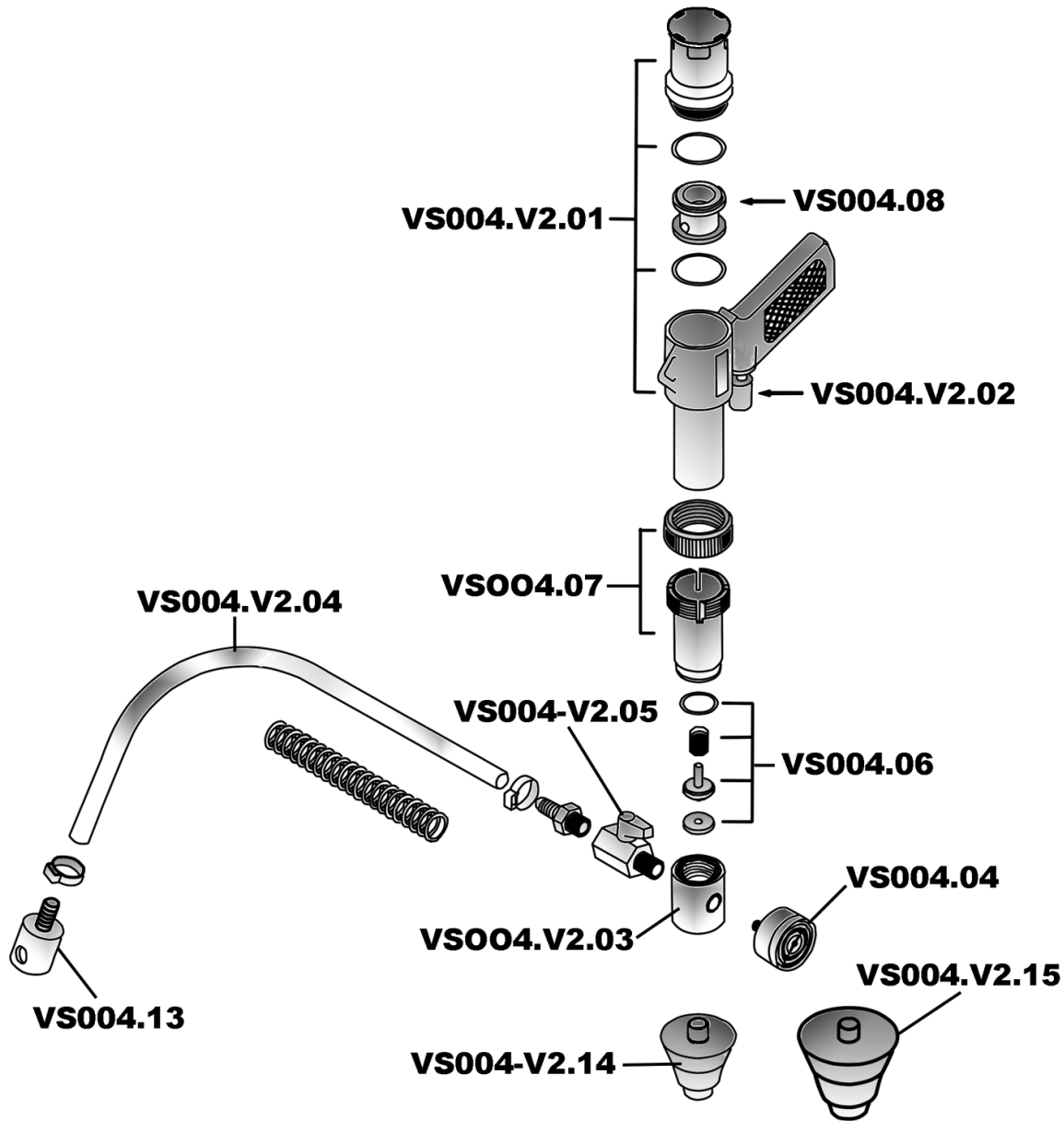

<u>Item.</u>	<u>Part No.</u>	<u>Description.</u>
1.	VS004-V2.01	VACUUM GUN ASS'Y.V2
2.	VS004-V2.02	TRIGGER ASS'Y REPAIR KIT
3.	VS004-V2.03	BODY ASS'Y
4.	VS004.V2.04	HOSE ASS'Y
5.	VS004.04	GAUGE
6.	VS004.V2.05	TAP ASS'Y
7.	VS004.06	CHECK VALVE KIT
8.	VS004.07	SLEEVE ASS'Y
9.	VS004.08	VACUUM MOTOR ASS'Y
10.	VS004.13	STRAINER
11.	VS004-V2.14	SMALL RUBBER CONE
12.	VS004-V2.15	LARGE RUBBER CONE