



INSTRUCTIONS FOR:
VACUUM OIL/FLUID EXTRACTORS
MANUAL OPERATION 6 & 18LTR
MODELS: **TP6905 & TP6906**

Thank you for purchasing a Sealey product. Manufactured to a high standard, this product will, if used according to these instructions and maintained properly, give you years of trouble free performance.

IMPORTANT: PLEASE READ THESE INSTRUCTIONS CAREFULLY. NOTE THE SAFE OPERATIONAL REQUIREMENTS, WARNINGS & CAUTIONS. USE THE PRODUCT CORRECTLY AND WITH CARE FOR THE PURPOSE FOR WHICH IT IS INTENDED. FAILURE TO DO SO MAY CAUSE DAMAGE AND/OR PERSONAL INJURY AND WILL INVALIDATE THE WARRANTY. KEEP THESE INSTRUCTIONS SAFE FOR FUTURE USE.



Refer to
Instruction
Manual



Wear
Protective
Clothing



Wear a
Face
Shield

1. SAFETY

- WARNING!** Ensure Health & Safety, local authority, and general workshop practice regulations are strictly adhered to when using this equipment.
- ✓ **Important!** Ensure that you wear protective clothing, gloves, goggles, face mask as appropriate for the fluid being extracted.
- ✓ Keep the extractor clean and maintain it in good condition (use an authorised service agent).
- ✓ Replace or repair damaged parts. *Use genuine parts only. Unauthorised parts may be dangerous and will invalidate the warranty.*
- ✓ Check extractor connections and fittings before use. When the unit is in use check that there are no leaks.
- ✓ Ensure that the extractor's tank capacity exceeds the amount of fluid to be collected.
- ✓ Ensure that the end of the suction tube is fully submerged in the fluid before operating.
- ✓ When not in use store in a safe, dry, childproof area.
- ✓ Keep the work area clean, uncluttered and ensure there is adequate lighting.
- ✓ Maintain correct balance and footing. Ensure the floor is not slippery and wear non-slip shoes.
- ✓ Keep children and unauthorised persons away from the working area.
- ✓ Dispose of waste fluids in accordance with local authority regulations.
- WARNING!** DO NOT allow uncontrolled discharge of fluids thus polluting the environment.
- ✓ Use only to extract engine or transmission oils, or similar NON-corrosive fluids. Unit may also be used for the transfer of water.
- ✗ DO NOT use to extract hazardous or harmful chemicals, solvents, petrol, diesel, kerosene, alkaline or acids. If by chance such fluids are used in the unit, it must be immediately drained and thoroughly cleaned. Use with prohibited fluids will invalidate your warranty.
- ✗ DO NOT store fluids in the extractor's tank. After extracting fluid, it must be emptied into an approved receptacle as soon as possible.
- ✗ DO NOT dismantle, tamper or adapt the extractor for any purpose other than for which it is designed.
- ✗ DO NOT store in areas of high temperature, direct sunlight, rain or snow.
- ✗ DO NOT connect these units to an air compressor.
- ✗ DO NOT dismantle these units.
- ✗ DO NOT leave these units in a pressurised state.
- WARNING!** When the extractor's tank contains liquid that is under pressure do not remove or insert the extension tube connector into the inlet/outlet fitting as this may result in a sudden discharge of liquid that could be dangerous.
- ✓ Always press the pressure relief button before connecting or disconnecting the extension tube.



2. INTRODUCTION & SPECIFICATION

6 and 18ltr capacity devices constructed from composite materials and suitable for extraction of all types of engine, transmission and lubricating oils from cars, motorcycles, marine engines, stationary engines and industrial machinery. Features a controlled discharge function for emptying the unit. Suitable also for low viscosity fluids such as water. Supplied with Ø5.8, Ø6.7mm suction probes and a 1.1mtr extension tube. Uses probes to drain engine oil through the dipstick hole. Also suitable for draining fish tanks, basins and sinks.

Model No: TP6905 TP6906
 Capacity: 6.5ltr 18ltr
 Probes: Ø5.8 x 870mm, Ø6.7 x 870mm Ø5.8 x 870mm, Ø6.7 x 870mm
 Extension tube: Ø9.8 x 1010mm Ø9.8 x 1010mm

3. MAIN FEATURES (TP6905 & TP6906)

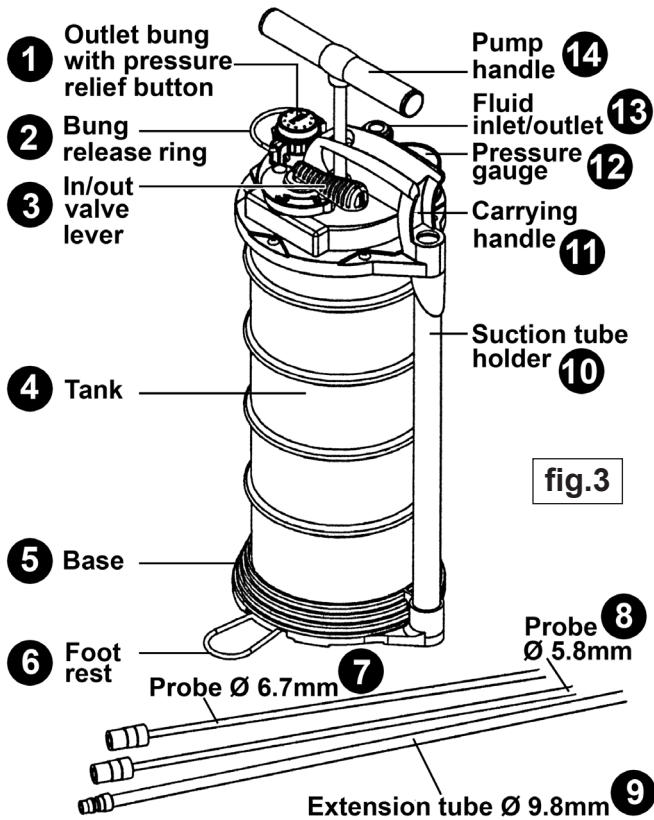

fig.3

MAIN FEATURES OF EXTRACTOR UNITS

- 3.1 **Outlet Bung.** The outlet bung is inserted into a small spout in the top of the unit which is used to manually empty oil out of the tank. The bung has an integral pressure relief button built into it. Press the button downwards into the bung and hold it there until the pressure has equalised.
- 3.2 **Bung Release Ring.** To remove the bung take hold of the bung release ring and turn the bung anti-clockwise until it stops. Pull upwards to remove the bung. To lock the bung in place insert it into the spout and turn it clockwise until it stops. The hooks on either side of the bung should now be trapped under the flanges on either side of the spout.
- 3.3 **IN/OUT valve lever.** When the valve lever is moved to the 'IN' position, operating the pump handle creates a vacuum, causing fluid to be sucked into the tank via the probe/extension tube. When the valve lever is moved to the 'OUT' position, operating the pump handle pressurises the tank causing fluid to be expelled from the tank.
- 3.4 **Tank.** After the unit has been used the tank should not be left in either a vacuum or pressurised state. Push in the pressure relief button and hold it down until the pressure has equalised.
- 3.5 **Base.** The base should be placed on a smooth level surface during operation.
- 3.6 **Footrest.** When extra stability is required during pumping fold out the footrest from underneath the base.
- 3.7 **Probe Ø6.7** This is the larger of the two probes provided and is intended for insertion into the dipstick tube of vehicles where an oil change is required. The red plastic fitting on this tube is a push fit onto the extension tube.

- 3.8 **Probe Ø5.8** This is the smaller of the two probes provided and is intended for insertion into the dipstick tube of vehicles where an oil change is required. The black plastic fitting on this tube is a push fit onto the extension tube.
- 3.9 **Extension tube Ø9.8** The fitting at one end of this tube fits directly into the Fluid inlet/outlet '13'. One of the probes will be a push fit onto the other end of this tube.
- 3.10 **Suction tube holder.** The extension tube and the two probes can be stored here when not required.
- 3.11 **Carrying handle.** The pump handle should be in the down position to use the carrying handle.
- 3.12 **Pressure gauge.** The needle moves anti-clockwise from zero when a vacuum is created to suck fluid into the tank. The needle moves clockwise from zero when the tank is pressurised to expel fluid from the tank. If the needle moves into the red zone the excess pressure will be automatically released.
- 3.13 **Fluid Inlet outlet.** This fitting has a sliding sleeve which has to be pulled downwards before the fitting on the end of the extension tube will go in.
- 3.14 **Pump handle.** The pump handle should be moved up and down through its full stroke for most efficient operation of the pump. If the pump handle locks up this means the tank is full. Press the pressure relief button to free the handle.

4. SET-UP FOR OIL CHANGE

Ensure you read, understand and apply the Section 1 Safety Instructions.

- 4.1 First ensure that the vehicle is level. Run the engine for approximately five minutes to ensure that the oil is warm. Switch off engine.



fig.4

- 4.2 Remove the oil dipstick from the engine.

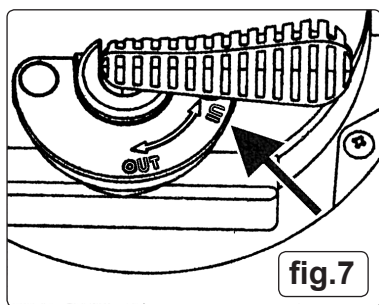
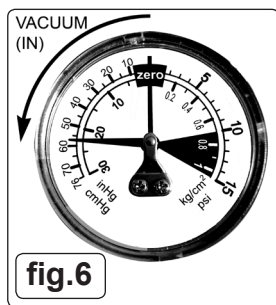

fig.5

- 4.3 Insert the appropriate extracting probe into the dipstick tube making sure it reaches the bottom of the sump. Connect the extracting probe to the extension tube using the black or red soft plastic adaptor. The tubes are a push fit into the adaptor.

- 4.4 Position the extractor close to the front or side of the vehicle. Plug the extension tube fitting into the fluid inlet/outlet fitting on top of the extractor (see fig.3-13).

5. OPERATION



5.1 DRAWING FLUID INTO THE EXTRACTOR

- 5.1.1 Before operating the extractor you must press the pressure release button (see fig.3-1) to dissipate any vacuum or pressure remaining in the tank from previous use. The pressure gauge needle should return to the zero position. **NOTE: The extractor should never be stored with any vacuum or pressure left within the tank.**
- 5.1.2 Set up the unit for oil extraction as described in Sections 4.1 to 4.4 so that the extractor probe is inserted into the vehicle's dipstick tube. The other end of the extractor probe should be joined to the extension tube with the adaptor provided and the extension tube should be connected to the inlet/outlet coupling (See fig.3-13). **NOTE: Extraction via the dipstick tube should only be done whilst the oil is warm.**
- 5.1.3 Move the IN/OUT valve lever to the IN position as shown in fig.7.
- 5.1.4 Fold out rod foot rest as shown in fig.3-6.
- 5.1.5 To commence suction place your foot over the foot rest to steady the unit and start to pump the handle up and down through its full travel. The needle on the gauge should move anti-clockwise from the zero position as shown in fig.6.
- 5.1.6 As you pump up and down, the tank will begin to fill. When the tank is full the auto shut off mechanism will operate and the pump handle will lock up. To return the handle to the down position hold down the pressure relief button and push the handle down.
- 5.1.7 Remove the extractor probe from the dipstick tube and replace the dipstick.

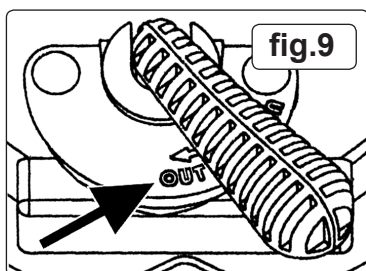
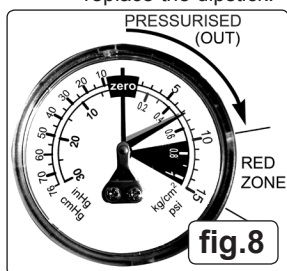

5.2 EXPELLING FLUID FROM THE EXTRACTOR

- 5.2.1 Place the end of the extension tube into a suitable container ensuring that it is large enough to hold the volume of liquid in the extractor's tank.
- 5.2.2 Move the IN/OUT valve lever to the OUT position as shown in fig.9.
- 5.2.3 Fold out rod foot rest as shown in fig.3-6.

- 5.2.4 To empty the extractor's tank place your foot over the foot rest to steady the unit and start to pump the handle up and down through its full travel. The needle on the gauge should move clockwise from the zero position as shown in fig.8. If excess pressure is created the needle will move into the red zone and the pressure will be automatically relieved.
- 5.2.5 As you pump up and down, the tank will begin to empty. Continue pumping until all fluid has been expelled. When the tank is empty, press the pressure relief button to dissipate any residual pressure remaining in the tank.
- 5.2.6 If extracted oil has cooled down and thickened we recommend that it should be poured from the extractor tank.
- 5.2.7 Remove the outlet bung from the pouring spout as described in Sections 3.1 and 3.2.

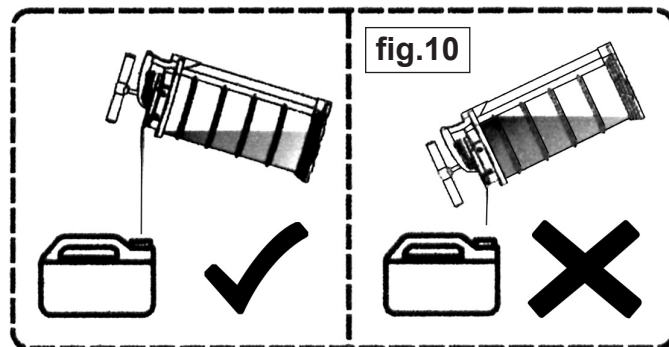

- 5.2.8 Pour the oil from the tank as shown above. Do not overtip the unit as this will result in inconsistent flow from the tank.
- 5.2.9 Insert the bung into the spout and turn fully anti-clockwise to lock in position for future use.
- WARNING!** When the extractor's tank contains liquid that is under pressure do not remove or insert the extension tube connector into the inlet/outlet fitting as this may result in a sudden discharge of liquid that could be dangerous. Always press the pressure relief button before connecting or disconnecting the extension tube.

6. SPARES

6.1	PART NO:	DESCRIPTION
6.1.1	TP6905.01	MAIN TUBE (9.8 x 1010mm)
6.1.2	TP6905.02	MIDDLE TUBE (6.7 x 870mm)
6.1.3	TP6905.03	SMALL TUBE (5.8 x 870mm)

Environmental Protection



Recycle unwanted materials instead of disposing of them as waste. All tools, accessories and packaging should be sorted, taken to a recycling centre and disposed of in a manner which is compatible with the environment. When the product becomes completely unserviceable and requires disposal, drain off any fluids (if applicable) into approved containers and dispose of the product and the fluids according to local regulations.

NOTE: It is our policy to continually improve products and as such we reserve the right to alter data, specifications and component parts without prior notice.

IMPORTANT: No liability is accepted for incorrect use of this product.

WARRANTY: Guarantee is 12 months from purchase date, proof of which will be required for any claim.



Sole UK Distributor, Sealey Group,
Kempson Way, Suffolk Business Park,
Bury St. Edmunds, Suffolk,
IP32 7AR



01284 757500



www.sealey.co.uk



01284 703534



sales@sealey.co.uk