

Thank you for purchasing a Sealey product. Manufactured to a high standard this product will, if used according to these instructions and properly maintained, give you years of trouble free performance.

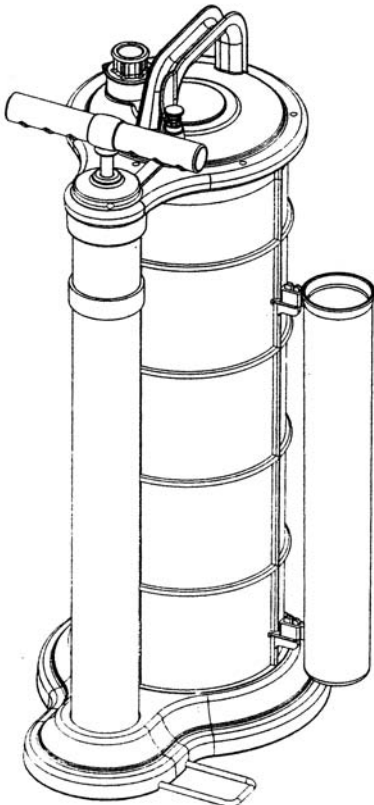

IMPORTANT: PLEASE READ THESE INSTRUCTIONS CAREFULLY. NOTE THE SAFE OPERATIONAL REQUIREMENTS, WARNINGS & CAUTIONS. USE THE PRODUCT CORRECTLY AND WITH CARE FOR THE PURPOSE FOR WHICH IT IS INTENDED. FAILURE TO DO SO MAY CAUSE DAMAGE AND/OR PERSONAL INJURY AND WILL INVALIDATE THE WARRANTY. PLEASE KEEP INSTRUCTIONS SAFE FOR FUTURE USE.

TP6901 MANUAL OPERATION ONLY



TP6903 AIR OPERATION ONLY

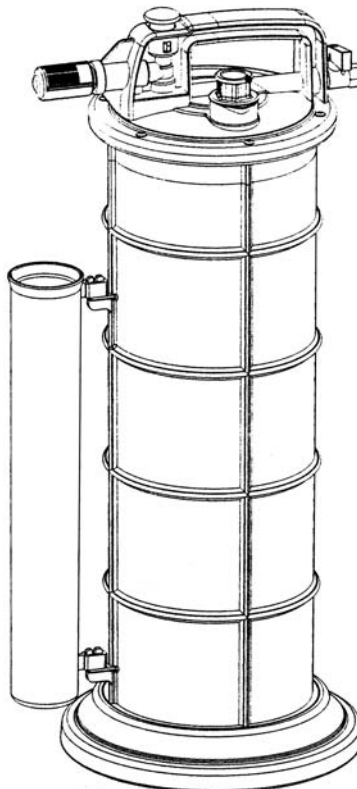

TP6904 MANUAL AND AIR OPERATION

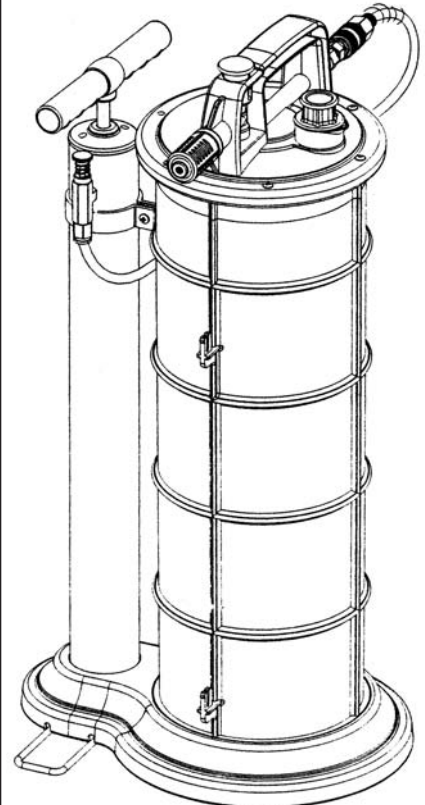

1. SAFETY INSTRUCTIONS

- WARNING!** Ensure Health & Safety, local authority, and general workshop practice regulations are strictly adhered to when using this equipment.
- WARNING!** Disconnect the extractor from the air supply before changing accessories, servicing or performing any maintenance.
- ✓ **Important!** Ensure that you wear protective clothing, gloves, goggles, face mask as appropriate for the fluid being extracted.
- ✓ Keep the extractor clean and maintain it in good condition (use an authorised service agent).
- ✓ Replace or repair damaged parts. *Use genuine parts only. Unauthorised parts may be dangerous and will invalidate the warranty.*
- ✓ Check extractor connections and fittings before use. When the extractor is turned on check that there are no leaks.
- ✓ Ensure that the extractor's tank capacity exceeds the amount of fluid to be collected.
- ✓ Avoid unintentional starting of the extractor and ensure that the end of the suction tube is fully submerged in the fluid before operating.
- ✓ When not in use, disconnect from the air supply and store in a safe, dry, childproof area.
- ✓ Keep the work area clean, uncluttered and ensure there is adequate lighting.
- ✓ Maintain correct balance and footing. Ensure the floor is not slippery and wear non-slip shoes.
- ✓ Keep children and unauthorised persons away from the working area.
- ✓ Dispose of waste fluids in accordance with local authority regulations.
- WARNING!** DO NOT allow uncontrolled discharge of fluids thus polluting the environment.
- DO NOT pull or yank any pipes or hoses and do not attempt to move the extractor by pulling the hose.
- DO NOT leave the extractor operating unattended.
- ✓ Use only to extract engine or transmission oils, or similar NON-corrosive fluids. Unit may also be used for the transfer of water.
- DO NOT use to extract hazardous or harmful chemicals, solvents, petrol, diesel, kerosene, alkaline or acids. If by chance such fluids are used in the unit, it must be immediately drained and thoroughly cleaned. Use with prohibited fluids will invalidate your warranty.
- DO NOT store fluids in the extractor's tank. After extracting fluid, it must be emptied into an approved receptacle as soon as possible.
- DO NOT dismantle, tamper or adapt the extractor for any purpose other than for which it is designed.
- DO NOT store in areas of high temperature, direct sunlight, rain or snow.
- DO NOT direct the air line at yourself or others.

2. INTRODUCTION & SPECIFICATION

9ltr Capacity devices constructed from composite materials. Uses manual pump or compressed air supply to generate vacuum. Suitable for the extraction of all types of engine, transmission and lubricating oils from cars, motorcycles, marine engines, stationary engines and industrial machinery. Suitable also for low viscosity fluids such as water. Supplied with Ø6 and Ø10mm suction probes and brake/clutch bleeding hose. Uses probes to extract engine oil through the dipstick tube.

Model No: TP6901 TP6903 & TP6904
 Capacity: 9ltr 9ltr
 Probes: Ø6 x 1100mm, Ø10 x 1100mm Ø6 x 1100mm, Ø10 x 1100mm
 Hose: Ø8 x 1100mm Ø8 x 1100mm
 Air Pressure N/A 70 -170psi
 Air Consumption: N/A 5cfm
 Max Oil/fluid Temp. All Models: 70°C

3. ASSEMBLY (ALL MODELS)

- 3.1 Cut the nylon ties which are holding the tube storage unit to the main tank. Identify the mounting hooks on the tank (See fig.1A). Place the mounting loops on the storage tube over the hooks on the tank and push downwards to snap the storage tube into place as shown in fig.2B.

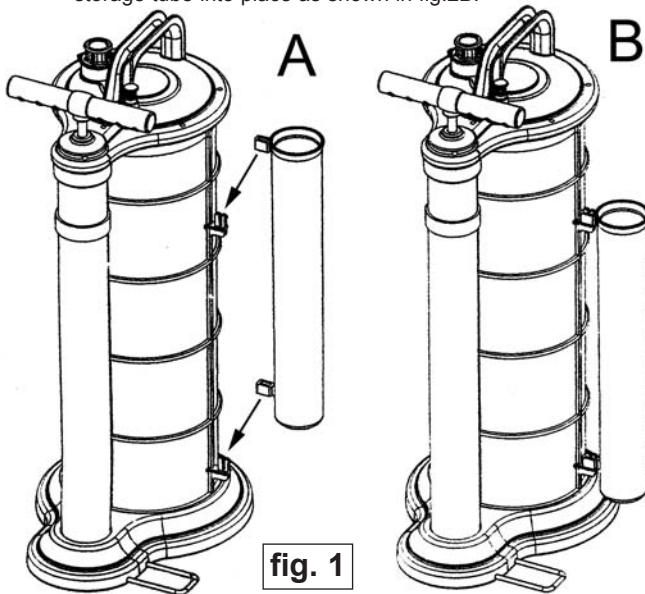

fig. 1

4. AIR SUPPLY (TP6903 & TP6904)

When using a workshop air supply, the recommended hook-up is shown below.

- 4.1. Ensure that the air valve (see fig.7) is in the "off" position before connecting to the air supply.
- 4.2. You will require an air pressure and an air flow (cfm) according to the specification above in section 2.
- WARNING!** Ensure the air supply is clean and does not exceed the pressure quoted. Too high an air pressure and/or unclean air will shorten the life of the extractor due to excessive wear and may be dangerous, causing damage and/or personal injury.
- 4.3. Drain the compressor air tank daily.
- 4.4. Clean compressor air inlet filter weekly.
- 4.5. Line pressure should be increased to compensate for unusually long air hoses (over 8 metres). The minimum bore for hose and fittings is 1/4".
- 4.6. Keep hoses away from heat, oil and sharp edges. Check hoses for wear and make certain that all connections are secure.

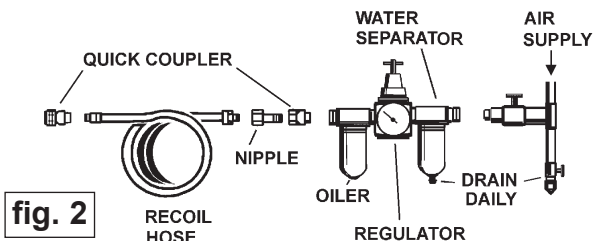

fig. 2

- 4.7 Pull back the sleeve on the quick coupling (See fig.3A) and remove the male threaded air coupling (See fig.3B). Wrap the thread in PTFE tape and screw the coupling into the air valve mounted at the rear of the handle (See fig.3C). Do not over tighten.

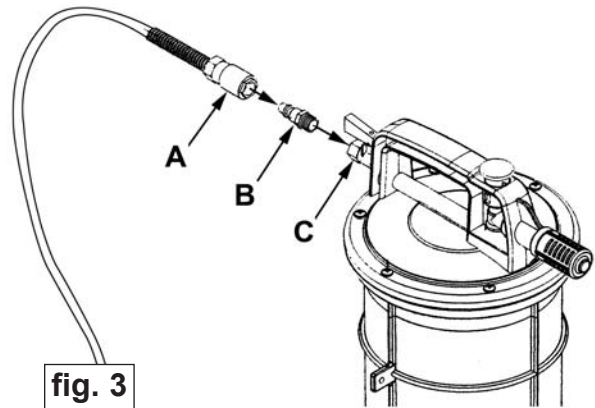

fig. 3

5. AIR OPERATION (TP6903 & TP6904)

Ensure you read, understand and apply the Section 1 Safety Instructions.

- 5.1. First ensure that the vehicle is level. Run the engine for approximately five minutes to ensure that the oil is warm. Switch off engine.
- WARNING!** Ensure oil/fluid temp. does not exceed 70°C.



fig. 4

- 5.2. Remove the oil dipstick from the engine.

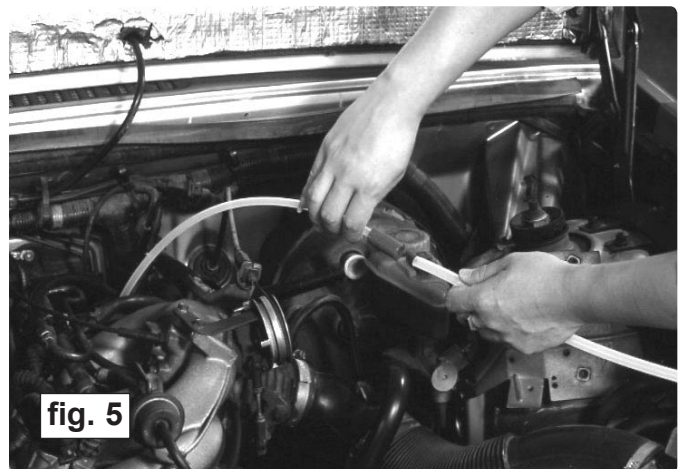

fig. 5

- 5.3. Insert the appropriate extracting probe into the dipstick tube making sure it reaches the bottom of the sump. Depending on the vehicle it may be necessary to insert the wire supplied in order to keep the tube more rigid as it passes down into the sump. Connect the extracting probe to the main suction tube using the black rubber adaptor. The tubes are a push fit into the adaptor.



fig. 6

- 5.4. Position the tank close to the front or side of the vehicle See fig.6 above. Connect the main suction tube to the fluid inlet coupling using the black rubber suction tube adaptor as shown below in fig.7.

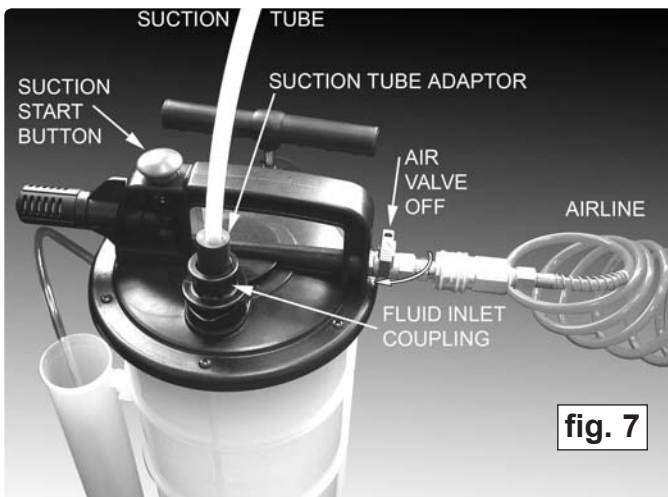

fig. 7

- 5.5 Connect an airline to the coupling at the back of the air valve and turn the air valve off as shown above. Adjust the air source to be between 70 and 170psi with an air flow of 5cfm.



fig. 8

- 5.6 To commence draining the sump turn the air valve on and press the blue button to start the suction as shown above in fig.8. When the fluid being drained reaches the top of the tank the unit will shut down automatically. If the fluid being drained is not sufficient to reach the auto shut off mechanism the unit can be shut down manually by turning off the air valve.

- 5.7 Disconnect the airline. Disconnect the suction tube from the unit by pulling out the fluid inlet coupling and pour the extracted fluid into a suitable container for disposal according to local authority regulations (see fig.10). Remove the extracting probe from the dipstick tube and re-insert the dipstick.

6. MANUAL OPERATION (TP6901 & TP6904)

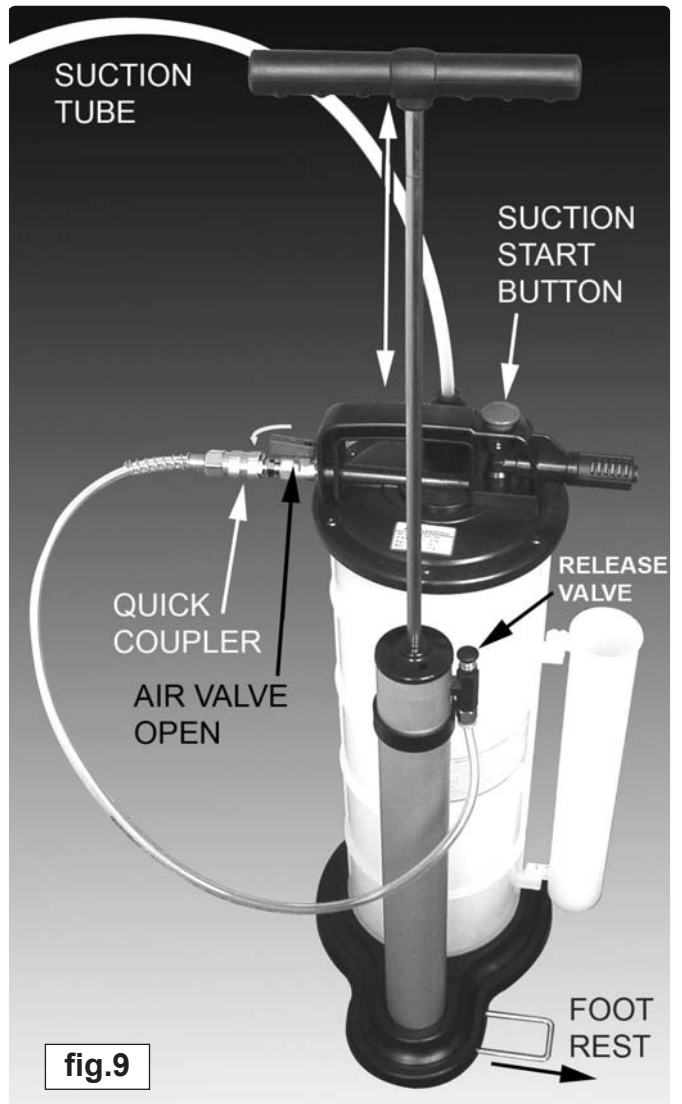

fig.9

- 6.1 Set up the unit for operation as described in Sections 5.1 to 5.4 so that the extractor probe is inserted into the vehicle's dipstick tube. The other end of the extractor probe should be joined to the main suction tube with the adaptor provided and the main suction tube should be connected to the tank using the fluid inlet coupling.
- 6.2 Extend the bent rod foot rest as shown in fig.9.
- 6.3 Referring to fig.9 connect the quick coupler on the end of the air hose from the hand pump to the air valve coupling and open the air valve (only relevant to TP6904).
- 6.4 To commence suction press the blue suction start button (TP6904 only) place your foot over the foot rest to steady the unit and start to pump the handle up and down through its full travel.
- 6.5 As you pump up and down, the tank will begin to fill. When the tank is full the auto shut off mechanism will operate and the pump handle will lock up. To return the handle to the down position hold down the release valve button at the top of the pump body and push the handle down (release valve is next to handle on TP6901).
- 6.6 If extraction is completed before the tank is full turn the air valve off manually (TP6904 only).
- 6.7 Remove the extractor probe from the dipstick tube and replace the dipstick. Unplug the fluid inlet coupling from the top of the unit and pour the extracted fluid into a suitable container as indicated in fig.10 overleaf. The fluid should be disposed of according to local authority regulations.



fig. 10

7. TROUBLESHOOTING

(A) PROBLEM: Unit will not start when the air valve is open and the blue button has been pressed.

(A1) Cause: The operation of the button will normally be accompanied by an audible 'click'. If this sound is not heard and there is no liquid in the reservoir turn the unit upside down and try again. Otherwise incline the unit to 45° and shake it several times then try again.

(A2) Cause: The unit may require internal lubrication. Disconnect the quick coupling. Open the air valve. Introduce a few drops of air tool oil into the male coupling and close the air valve. Reconnect the quick coupling. When the unit is next operated the oil will be distributed internally.

(B) PROBLEM: Automatic shut off does not operate when the tank is full.

(B1) Cause: Turn air off manually and empty tank.
and solution: Take action as described in A1 and A2.

(C) PROBLEM: Extractor is working but no fluid is being extracted.

(C1) Cause: All fluid has been extracted but tank is not full.
and solution: Turn off air manually.

(C2) Cause: Extractor probe is not fully immersed in the fluid.
and solution: Push extractor probe further into liquid/engine sump.

(C3) Cause: Tank is full.
and solution: Empty tank.

8. BRAKE BLEEDING SAFETY

- ✓ Dispose of waste liquids in accordance with local authority regulations.
- ✓ Always read and comply with the warnings on the brake fluid container.
- ✓ Wear eye protection and keep skin contact to a minimum. If brake fluid enters eyes rinse with plenty of water and seek medical advice. If swallowed seek medical advice immediately.
- ❑ **WARNING!** Brake fluid is flammable - keep away from sources of ignition, including hot surfaces e.g. exhaust manifold.
- ❑ **WARNING!** Brake fluid will damage paintwork. Any spillage should be flushed with water immediately.

NOTE: It is our policy to continually improve products and as such we reserve the right to alter data, specifications and component parts without prior notice.

IMPORTANT: No liability is accepted for incorrect use of this product.

WARRANTY: Guarantee is 12 months from purchase date, proof of which will be required for any claim.

INFORMATION: For a copy of our latest catalogue and promotions call us on 01284 757525 and leave your full name and address, including postcode.

9. BRAKE BLEEDING OPERATION

fig.11

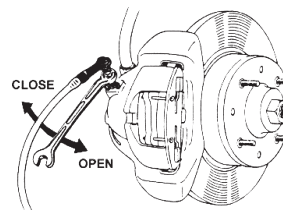

BRAKE BLEEDING PROCEDURE. Do not touch the vehicle's brake pedal whilst bleeding the brakes.

Refer to the vehicle manufacturer's instructions for brake bleeding and wheel sequence before proceeding. If no specific instructions from the vehicle manufacturer exist, follow the instructions detailed below.

❑ **WARNING! Familiarise yourself with the hazards of brake fluid - read manufacturer's instructions on the container.**

- 9.1 Remove the lid of the vehicle's brake fluid reservoir. Fill the reservoir to its maximum mark.
- 9.2 Identify the brake bleeding tube which has a blue flexible plastic brake nipple connector at one end and a black rubber adaptor at the other.
- 9.3 Connect the brake bleeding tube to the top of the fluid extractor's tank by pushing the black rubber adaptor into the fluid inlet coupling.
- 9.4 Push the blue flexible plastic brake nipple connector onto the brake nipple on the first wheel and open the nipple about 1/4 of a turn. (See fig.11)
- 9.5 Turn on the air valve on the extractor (TP6903 & TP6904). Press the blue button to activate air operated units or operate the pump handle on manual models. A vacuum will be created which will draw the brake fluid from the vehicle's brake system. Operate the unit for a few seconds only to avoid entirely draining the vehicle's brake fluid reservoir.
- 9.6 **IMPORTANT: Check the level of brake fluid in the vehicle's reservoir and top up regularly. If possible a reservoir top up device should be fitted to the brake fluid reservoir.**
- 9.7 Continue to bleed the system and top up the reservoir until there are no air bubbles visible in the clear tube (See fig.12).
- 9.8 Close the brake nipple (See fig.11).
- 9.9 Remove the rubber pipe from the brake nipple.
- 9.10 Repeat the process at each wheel in turn.

fig.12

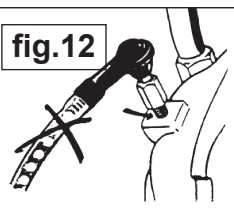
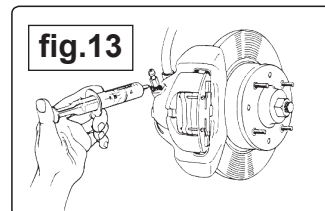

fig.13



9.11 Changing the brake fluid

- 9.11.1 Repeat the brake bleeding procedure as described above until the master cylinder reservoir is at its minimum level. Fill the reservoir with new brake fluid and continue to bleed the system. Check reservoir level regularly.
- 9.11.2 When new fluid can be seen in the clear tube tighten the brake nipple.
- 9.11.3 Repeat this procedure at every wheel.
When brake bleeding and/or fluid changing is complete, test action of brake pedal to ensure that the brakes are working before driving the vehicle.
- 9.11.4 Apply copper grease to the brake bleed nipples before and after the brake bleeding procedure to eliminate the possibility of seized or broken nipples when the brakes are next bled (See fig.13).



Sole UK Distributor, Sealey Group,
Kempson Way, Suffolk Business Park,
Bury St. Edmunds, Suffolk,
IP32 7AR

☎ 01284 757500

☎ 01284 703534

🌐 www.sealey.co.uk

✉ sales@sealey.co.uk

