

Thank you for purchasing a Sealey product. Manufactured to a high standard this product will, if used according to these instructions and properly maintained, give you years of trouble free performance.



IMPORTANT: PLEASE READ THESE INSTRUCTIONS CAREFULLY. NOTE THE SAFE OPERATIONAL REQUIREMENTS, WARNINGS AND CAUTIONS. USE THE PRODUCT CORRECTLY AND WITH CARE FOR THE PURPOSE FOR WHICH IT IS INTENDED. FAILURE TO DO SO MAY CAUSE DAMAGE AND/OR PERSONAL INJURY AND WILL INVALIDATE THE WARRANTY. PLEASE KEEP INSTRUCTIONS SAFE FOR FUTURE USE.

1. SAFETY INSTRUCTIONS

GENERAL SAFETY

- ❑ **WARNING!** Ensure Health & Safety, local authority, and general workshop practice regulations are adhered to when using this equipment. Under Health and Safety Law, Employers and Self Employed Personnel have a legal duty to ensure Safe Working Conditions for all employees and personnel that may come into contact with this equipment. In particular they must carry out a specific risk and hazard assessment in the workplace to eliminate or reduce any risk found and must record, update and retain records of the results of this inspection.
- ✓ Familiarise yourself with the applications, limitations and any possible or potential hazards of the tyre changer.
- ✓ Maintain the tyre changer in good condition (use an authorised service agent).
- ✓ Replace or repair damaged parts. Use genuine parts only. Unauthorised parts may be dangerous and will invalidate the warranty.
- ❑ **WARNING!** Check regularly for damaged parts. Any part that is damaged must be repaired or replaced before the equipment is next used.
- ✓ Locate the tyre changer in a suitable work area, keep area clean and tidy and free from unrelated materials. Ensure that there is adequate lighting.
- ❑ **WARNING! Use on a level surface, preferably concrete, to which the tyre changer must be bolted.**
- ✓ Keep the tyre changer clean for best and safest performance.
- ✓ Wear approved safety eye protection (standard spectacles are not adequate).
- ✓ Keep hands and feet well clear of the bead breaker.
- ✓ Maintain correct balance and footing. Ensure the floor is not slippery and wear non-slip safety shoes.
- ✓ Remove ill fitting clothing. Remove ties, watches, rings, and other loose jewellery and contain and/or tie back long hair.
- ✓ Keep children and unauthorised persons away from the work area.
- x **DO NOT** use the tyre changer for any purpose other than that for which it is designed.
- x **DO NOT** operate the tyre changer if any parts are damaged or missing as this may cause failure and/or personal injury.
- x **DO NOT** allow untrained persons to operate the tyre changer.
- x **DO NOT** stand on the tyre changer.
- x **DO NOT** operate the tyre changer when you are tired or under the influence of alcohol, drugs or intoxicating medication.

2. SPECIFICATIONS

Heavy-duty tyre changer suitable for wide variety of tyres and wheels including those fitted to motorcycles, ATVs, go-karts and golf buggies. Works on bearing or hub centred wheels and is supplied with two centre posts. Includes manual bead breaker and supplied with tyre bar for mounting and de-mounting. Fast and simple operation.

Model:	TC965
Minimum Wheel Size:	102mm
Maximum Wheel Size:	420mm
Centre Post Sizes:	13mm, 16mm & 19mm

3. ASSEMBLY

Refer to contents diagram fig.1 and table of contents.

- 3.1 Attach the Jaw Frame (19) to the Main Stand (4), using bolts (22), washers (23) and lock nuts (9) (fig.2).
- 3.2 Attach Pivot Arm (7) to the Main Stand using lock pin (8) (fig.3).
- 3.3 Attach the Bead Breaker (5) to the bracket on the Pivot Arm (7) using bolt (6) and lock nut (9) (fig.4).
- 3.4 Insert the Handle (10) into the Pivot Arm (7) using bolt (24) and lock nut (12) (fig.5).
- 3.5 Slide the two Jaws (20) on to the arms of the Jaw Frame (19) and locate using lock pins (21). Attach the Threaded Rod Assembly (14) to the Adjustable Jaw (17) and slide onto the remaining arm, secure the assembly to the arm using bolt (15) and locking nut (12). Attach Crank Arm (13) to the end of the Threaded Rod Assembly (14) using locking nuts (12).
- 3.6 Insert End Caps (16) into each of the three Jaw Frame arms and fit the plastic covers onto the three jaws.
- 3.7 Locate the tyre changer in a suitable working area, allow a minimum of 1 metre working space around the assembly and secure to the floor.



TC965

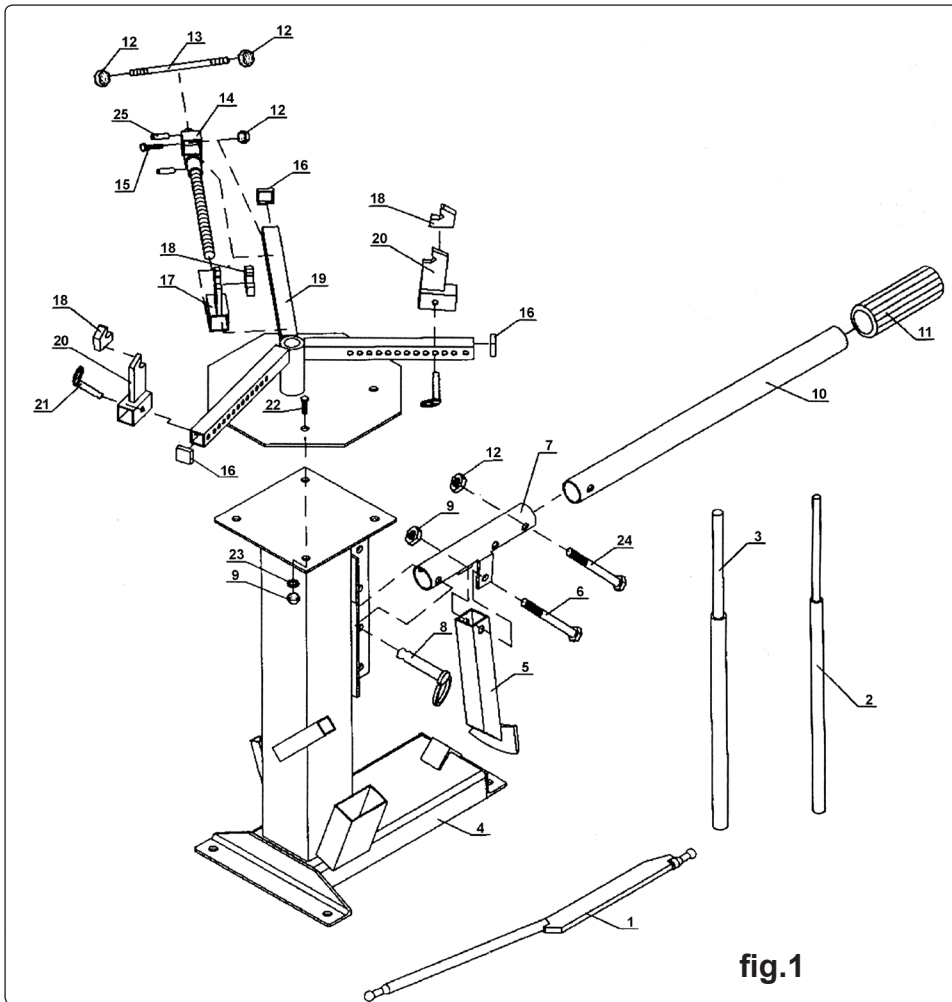

fig.1

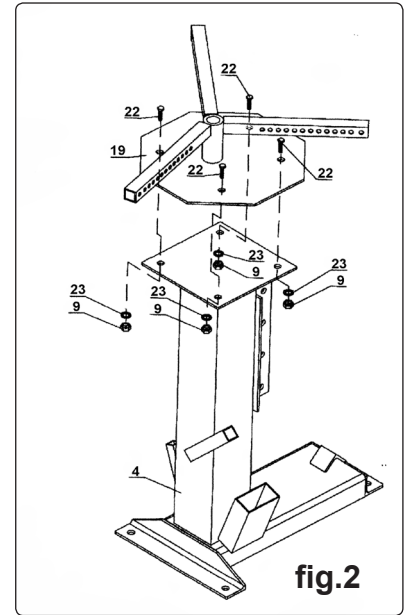

fig.2

Contents					
1	Tyre Bar	10	Handle	19	Jaw Frame
2	Small Post	11	Handle Grip	20	Jaw
3	Large Post	12	Lock Nut M10	21	Lock Pin 8mm
4	Main Stand	13	Crank Arm	22	Bolt M12 x 25
5	Bead Breaker	14	Threaded Rod Assembly	23	Large Washer
6	Bolt M12 x 65	15	Bolt M10 x 40	24	Bolt M10 x 55
7	Pivot Arm	16	End Cap	25	Roll Pin 6 x 22mm
8	Lock Pin 12mm	17	Adjustable Jaw		
9	Lock Nut M12	18	Jaw Cover		

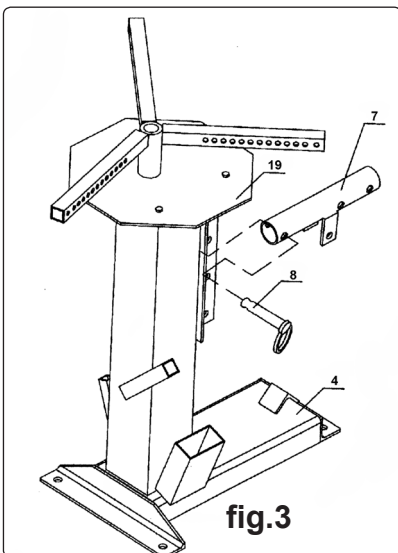

fig.3

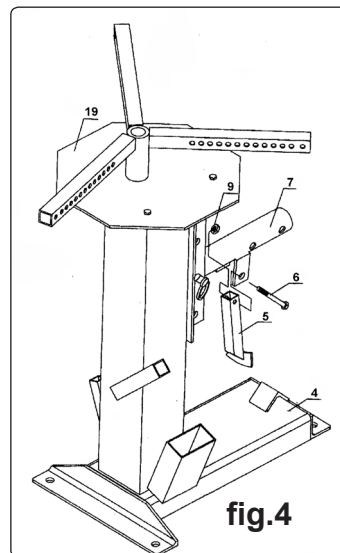

fig.4

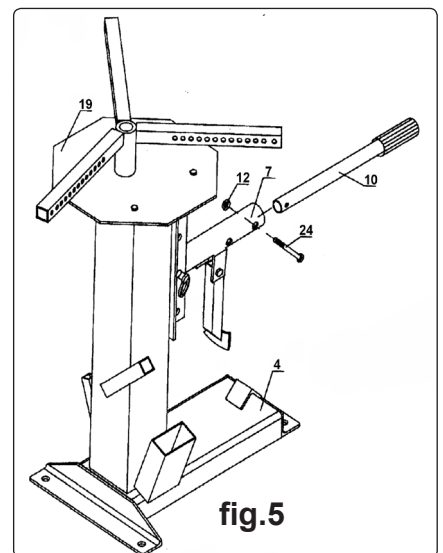

fig.5

4. OPERATION

The **TC965** Tyre Changer is manually operated - no air supply is required. It is designed for removing/fitting tyres from/to most sizes of open-centre wheels (see Section 3 Specifications). Do not use the tyre changer for any other purpose.

If tyres are to be changed on aluminium wheels the optional tyre bar, Sealey model no: **TC963**, must be used to prevent damage to the wheel rims (fig.6).

IMPORTANT! Never attempt to fit or remove a tyre without first lubricating both beads.

4.1 Bead breaking

- 4.1.1 Remove the valve core to deflate the tyre and remove all balance weights.
- 4.1.2 Lift the bead breaker clear of the tyre changer foot.
- 4.1.3 Place the wheel on the foot of the tyre changer, locating the rim on the raised bar on the foot.
- 4.1.4 Set the bead breaker arm at the appropriate height for the wheel and position the bead breaker shoe under the rim flange (fig.7).
- 4.1.5 Pull down firmly on the bar and repeat around the rim until the bead is free (fig.8).
- 4.1.6 Turn wheel over and repeat to free the other bead.

Note: When bead breaking on TD or TDX wheels the wheel **must be horizontal**. Locate the rim on the foot of the tyre changer and support the opposite side of the wheel with a suitable piece of timber.



Tyre bar TC963
for alloy wheels (Optional)

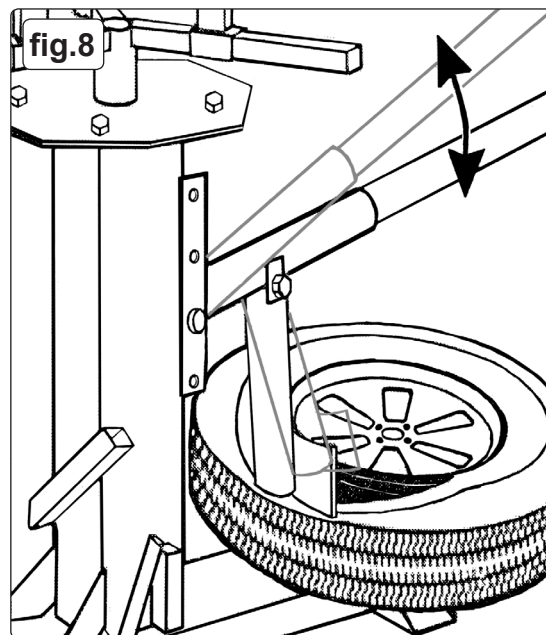
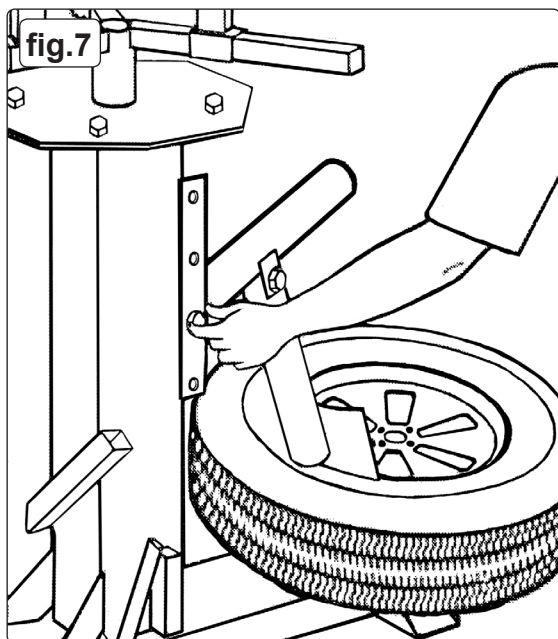

4.2. Tyre removal

- 4.2.1 Lubricate both tyre beads with an approved rubber lubricant.
- 4.2.2 Place the wheel centrally onto the stand with the narrow bead seat uppermost, slide the two rim clamping jaws, so that they locate on the rim of the wheel and insert 8mm locking pins. Use the crank arm to wind in the adjustable jaw until the wheel is securely fixed.

Note: The tyre may require lifting slightly to locate the jaws on the rim, take care not to trap the tyre in the jaws.

Note: Figs 9 & 10 shown without tyre to demonstrate the clamping mechanism.

- 4.2.3 Insert the appropriate centre post through the centre of the wheel into the tyre changer (fig.10).

Note: When changing tyres on bearing centre wheels use the centre post which matches the bearing size of the wheel.
For hub-centre wheels the large centre post is used.

- 4.2.4 Insert the ball end of the tyre bar beneath the top bead and press the opposite side of the bead down into the wheel well with the tyre bar against the centre post rotate the tool full circle (fig.11) until the bead is lifted above the rim. Remove inner tube (if fitted).
- 4.2.5 Lift the tyre up and repeat the procedure for the lower bead (fig.11).

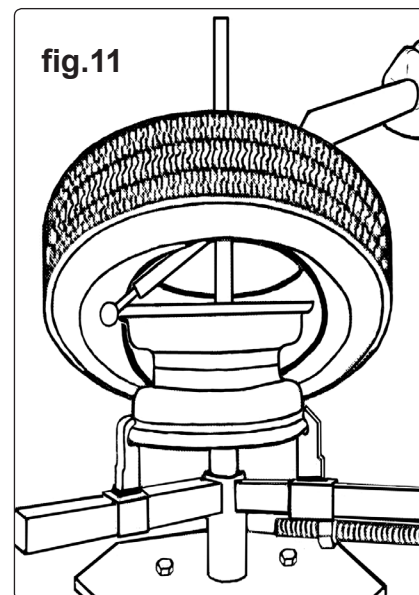
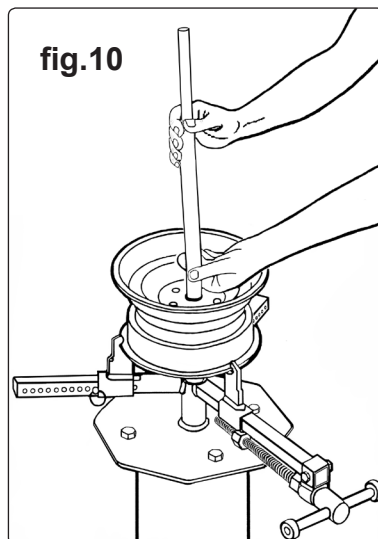
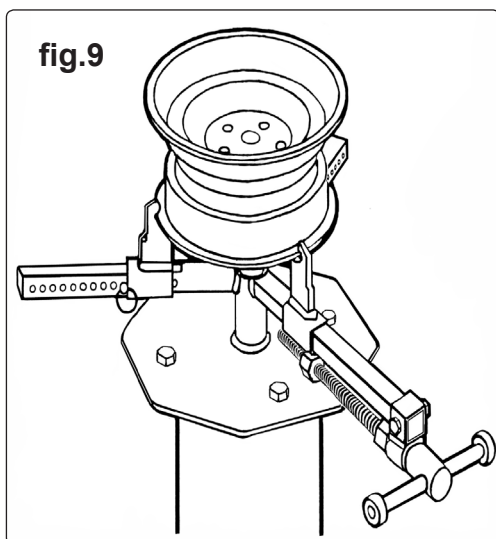

4.3 Tyre fitting

4.3.1 Lubricate both tyre beads with an approved rubber lubricant.

4.3.2 Mount and lock the wheel to the stand as shown in fig.12.

4.3.3 Place the lower bead of the tyre over the wheel rim and using the flat-end of the tyre bar place the ball end between the bead and the rim with the flat side of the tyre bar against the centre post rotate the tool full circle (fig.13).

4.3.4 Fit a tube if appropriate and then seat the upper bead in the same manner.

4.3.5 Refit valve core, remove wheel from the tyre changer and inflate to seat the beads. Adjust the tyre pressure to manufacturers specifications.

Note: If the tyre has been fitted with an inner tube take care not to trap the tube between the tyre and the wheel rim when bead seating.

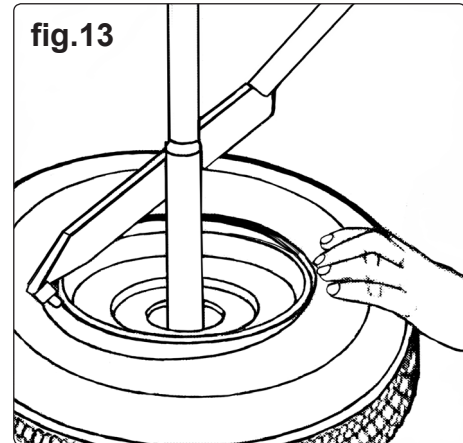
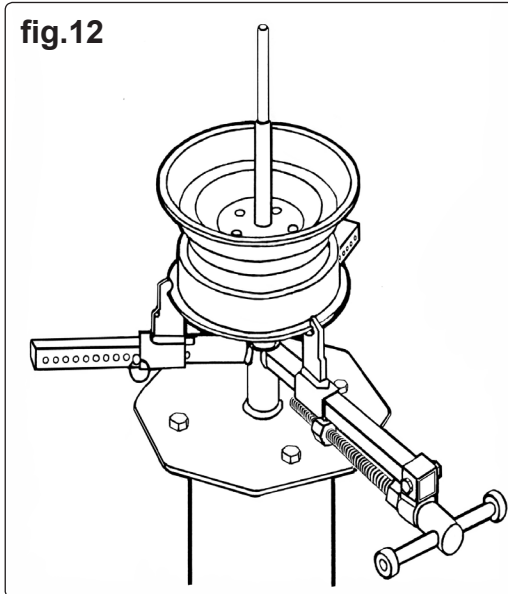

5. MAINTENANCE

5.1 Every month lubricate the threaded bar with grease.

5.2 Keep the tyre changer clean, use water and a mild detergent.

5.3 Check the tyre changer and components for damage or wear and replace parts if damaged.

Parts support is available for this product.

To obtain a parts list and diagram please log on to www.sealey.co.uk, email sales@sealey.co.uk or phone 01284 757500

6. DECLARATION OF CONFORMITY

MOTORCYCLE & MINI TYRE CHANGER
Model No: TC965
2006/42/EC Machinery Directive
93/68/EEC CE Directive

Declaration of Conformity We, the sole distributor in the UK, declare that the product listed here is in conformity with the following standards and directives.



The construction file for this product is held by the Manufacturer and may be inspected, by a national authority, upon request to Jack Sealey Ltd.

Signed by Tim Thompson  24th October 2008

For Jack Sealey Ltd. Sole distributor in the UK of Sealey Professional Tools.

NOTE: It is our policy to continually improve products and as such we reserve the right to alter data, specifications and component parts without prior notice.

IMPORTANT: No liability is accepted for incorrect use of this product.

WARRANTY: Guarantee is 12 months from purchase date, proof of which will be required for any claim.

INFORMATION: For a copy of our latest catalogue and promotions call us on 01284 757525 and leave your full name and address, including postcode.

SEALEY Professional
TOOLS
AUTO SERVICE LINE

Sole U.K. Distributor
Sealey Group
Bury St. Edmunds
Suffolk.



01284 757500



01284 703534



www.sealey.co.uk



sales@sealey.co.uk