



DIGITAL INSULATION TESTER

MODEL NO: **TA319.V2**

Thank you for purchasing a Sealey product. Manufactured to a high standard, this product will, if used according to these instructions, and properly maintained, give you years of trouble free performance.

IMPORTANT: PLEASE READ THESE INSTRUCTIONS CAREFULLY. NOTE THE SAFE OPERATIONAL REQUIREMENTS, WARNINGS & CAUTIONS. USE THE PRODUCT CORRECTLY AND WITH CARE FOR THE PURPOSE FOR WHICH IT IS INTENDED. FAILURE TO DO SO MAY CAUSE DAMAGE AND/OR PERSONAL INJURY AND WILL INVALIDATE THE WARRANTY. KEEP THESE INSTRUCTIONS SAFE FOR FUTURE USE.



Refer to instruction manual



Warning! Electricity

1. SAFETY

- ❑ **WARNING!** USE EXTREME CAUTION when working with high voltages.
- ✓ When using this meter, please observe all normal safety rules concerning:
 - ✓ Protection against the dangers of electrical current.
 - ✓ Protection of the meter against misuse.
 - ✓ Familiarise yourself with the applications, limitations and hazards of the tester. If in any doubt consult a qualified electrician.
 - ✓ Read the following safety information carefully before attempting to operate or service the meter.
 - ✓ To avoid damages to the instrument **DO NOT** apply the signals which exceed the maximum limits shown in the technical specifications.
- ✗ **DO NOT** use the meter or test leads if they look damaged. Use extreme caution when working around bare conductors or bus bars.
- ✓ Accidental contact with the conductor could result in electric shock.
- ✓ Use the meter only as specified in this manual; otherwise, the protection provided by the meter may be impaired.
- ✓ Read the operating instructions before use and follow all safety Information.
- ✓ Caution when working with voltages above 60V dc or 30V ac RMS. Such voltages pose a shock hazard.
- ✓ Before taking resistance measurements or testing acoustic continuity, disconnect circuit from main power supply and all loads from the circuit.

NOTE: The warnings, cautions and instructions referred to in this manual cannot cover all possible conditions and situations that may occur. It must be understood that common sense and caution are factors which cannot be built into this product, but must be applied by the operator.

2. INTRODUCTION

Specially designed for testing insulation on high voltage cables. Suitable for hybrid and electric vehicles. Supplied with test leads, batteries and carry-case. Conforms to EN61010 CAT III (1000V).

3. SPECIFICATION

Model No: **TA319.V2**
Voltage AC: Range 750V, Max. resolution 1V, Accuracy ($\pm 1.2\% \pm 10$ digits)
Voltage DC: Range 1000V, Max. resolution 1V, Accuracy ($\pm 0.8\% \pm 3$ digits)
Resistance:
 Range 200 Ω - 2000 Ω , Max. resolution 0.1 Ω - 1 Ω , Accuracy ($\pm 1\% \pm 2$ digits)
Insulation Resistance:
 Range 200M Ω - 2000M Ω , Max. resolution 100k Ω - 1M Ω , Accuracy ($\pm 3.5\% \pm 5$ digits)
Test Voltage: 250V - 200M Ω , 500V - 200M Ω , 1000V - 2000M Ω
Continuity Test: Active sound level ≤ 40 dB, Test current ≤ 200 mA
Operating Temperature: 0 $^{\circ}$ C - 40 $^{\circ}$ C (<80%R.H.)
Storage Temperature: -10 $^{\circ}$ C - 60 $^{\circ}$ C (<70%R.H.)
Batteries (supplied): 6 x 1.5V AA

4. CONTROLS

1	Digital display
2	Data hold button
3	Lock button
4	Backlight button
5	Test button
6	Rotary function switch
7	V Ω jack
8	COM input jack



5. OPERATION

5.1. CONNECTING LEADS

- 5.1.1. **On MΩ Range:** Connect the red test lead into the VΩ terminal and the black terminal into the COM terminal.
- 5.1.2. **On 200Ω and ACV Range:** Connect the red test lead into the "VΩ" terminal and the black lead into terminal "COM".

5.2. TEST LEADS CHECK

- 5.2.1. Set the range select switch to the 200Ω range. With the tip and alligator clip of the test leads connected, the indicator should read 00.0Ω. When the leads are not connected the display will read infinity indicated by "1". This will ensure that test lead are under working condition.

5.3. BATTERY CHECK AND REPLACEMENT

- 5.3.1. If battery power is insufficient the LCD will display . 6 x 1.5V AA batteries are required.
- 5.3.2. Remove the four screws which hold the battery cover to fit batteries.

5.4. INSULATION RESISTANCE MEASUREMENT

5.4.1. Measurements at 200mΩ/250V

- 5.4.2. This is the voltage used for the majority of insulation resistance tests on normal installations.
- 5.4.2.1. To measure insulation resistance, press the test button to power on the tester. The LCD will display the insulation resistance. Section VII indicated that subdivision of large installations might be necessary because of the large number of parallel insulation resistance. In such a case, an installation may be divided into sections, each being separately tested. Each section must have not less than fifty outlets, an outlet being a switch, socket, lighting point etc. A switched socket counts as one outlet. The minimum acceptable insulation resistance is 1MΩ. For a large installation, the capacitance of the insulation will be high, and it will take longer for it to become charged by the direct testing voltage. Care must be taken not to take a reading until there is a steady reading, indicating that the charging process is complete.

NOTE: The charge stored in the insulation will be discharged automatically when the test button is released. Be careful not to turn the range switch knob whilst the test button is pressed, or the instrument will be damaged.

5.4.3. Measurements at 2000mΩ/1000V

- 5.4.3.1. Some specifications require testing at 1000V. This voltage must also be selected where the supply voltage of the installation is between 500V and 1000V. First, set the range switch to 1000V and then proceed as indicated above for 500V testing. The above note also applies to testing at 1000V. In addition the following applies.

NOTE: Make sure that the circuit under does not include components which will be damaged by the 1000V applied. Many normal components of an installation are likely to be damaged if tested at 1000V. Examples are power factor correction capacitors, low voltage mineral insulated cables, electronic light dimmers, electronic ballasts and starters for fluorescent lamps etc.

5.5. LOCK POWER ON FEATURE

- 5.5.3.1. For hands free operation a lock power on feature is incorporated on the press to test button. Set LOCK button to lock test voltage, pressing it again will turn the tester off.

5.6. LOW RESISTANCE (CONTINUITY MEASUREMENTS)

- 5.6.1. Set the range switch to 200Ω position.
- 5.6.2. Connect the red test lead to the V Ω terminal and black to the COM terminal.
- 5.6.3. Connect the tips of the test leads to both ends of the circuit under test. Read resistance in Ω on the LCD.
- 5.6.4. When the impedance on circuit is below approximately 40Ω. It will indicate by a continuous beeper.

5.7. AC/DC VOLTAGE MEASUREMENTS

- 5.7.1. Set the range switch to acV or dcV position.
- 5.7.2. Connect red test lead to "V Ω" terminal and black test lead to terminal "COM".
- 5.7.3. Connect test prods of test leads IN PARALLEL to the circuit being measured.
- 5.7.4. Read the voltage value on LCD.

5.8. POWER TOOLS AND SMALL APPLIANCES See (fig.1)

- 5.8.1. This test would also apply to other similar equipment that has a power cable. For double insulated power tools, the megohmmeter lead shown connected to the housing would be connected to some metal part of the tool (e.g chuck or blade).

NOTE: The switch of the device must be in the "ON" position and the mains power should be disconnected.

5.9. AC MOTORS Refer to (fig.1)

- 5.9.1. Disconnect the motor from the line by disconnecting the wires at the motor terminals or by opening the main switch. If the main switch is used and the motor also has a starter then the starter must be held, by some means, in the "ON" position. In the latter case, the measured resistance will include the resistance of the motor, wire and all other components between the motor and the main switch. If a weakness is indicated, the motor and other components should be checked individually. If the motor is disconnected at the motor terminals, connect one megohmmeter lead to the grounded motor housing and the other lead to one of the motor leads.

5.10. DC MOTORS Refer to (fig.1)

- 5.10.1. Disconnect the motor from the line. To test the brush rigging, field coils and armature connect one megohmmeter lead to the grounded motor housing and the other lead to the brush on the commutator. If the resistance measurement indicates a weakness, raise the brushes off the commutator and separately test the armature, field coils and brush rigging by connecting one megohmmeter lead to each of them individually, leaving the other connected to the grounded motor housing. The above also applies to dc generators.

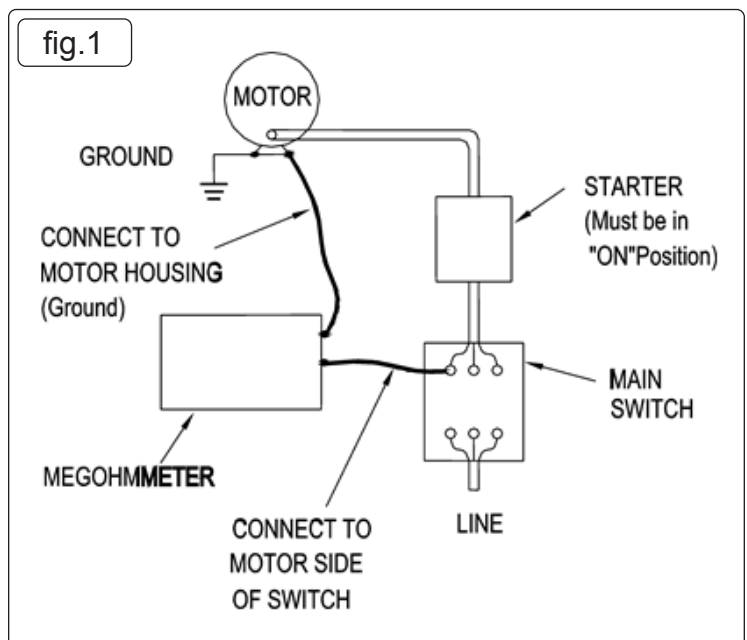

5.11. CABLES Refer to (fig.2)

5.11.1.1. Disconnect the cable from the line, also disconnect the opposite end to avoid errors due to leakage from other equipment. Check each conductor to ground and /or lead sheath by connecting one megohmmeter lead to a ground and /or lead sheath and the other megohmmeter lead to each of the conductors in turn. Check insulation resistance between conductors by connecting megohmmeter leads to conductors in pairs.

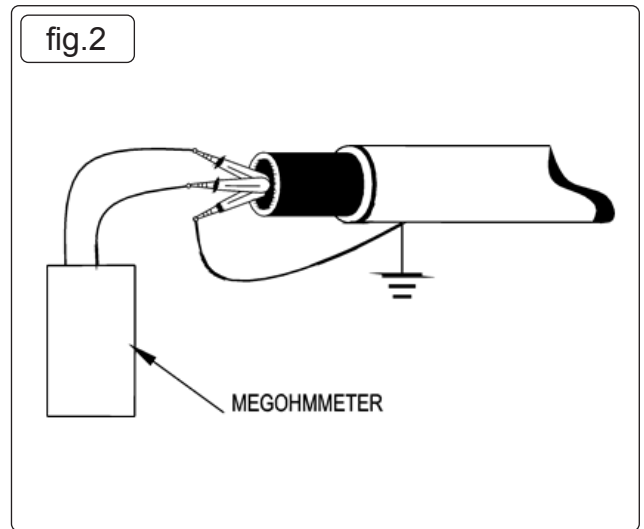

Parts support is available for this product. Please log on to www.sealey.co.uk, email sales@sealey.co.uk or telephone 01284 757500



ENVIRONMENT PROTECTION

Recycle unwanted materials instead of disposing of them as waste. All tools, accessories and packaging should be sorted, taken to a recycling centre and disposed of in a manner which is compatible with the environment. When the product becomes completely unserviceable and requires disposal, drain any fluids (if applicable) into approved containers and dispose of the product and fluids according to local regulations.



WEEE REGULATIONS

Dispose of this product at the end of its working life in compliance with the EU Directive on Waste Electrical and Electronic Equipment (WEEE). When the product is no longer required, it must be disposed of in an environmentally protective way. Contact your local solid waste authority for recycling information.



BATTERY REMOVAL

Under the Waste Batteries and Accumulators Regulations 2009, Jack Sealey Ltd are required to inform potential purchasers of products containing batteries (as defined within these regulations), that they are registered with Valpak's registered compliance scheme. Jack Sealey Ltd Batteries Producer Registration Number (BPRN) is BPRN00705.

Note: It is our policy to continually improve products and as such we reserve the right to alter data, specifications and component parts without prior notice.

Important: No Liability is accepted for incorrect use of this product. Please note that other versions of this product are available. If you require documentation for alternative versions, please email or call our technical team on technical@sealey.co.uk or 01284 757505.

Warranty: Guarantee is 12 months from purchase date, proof of which is required for any claim.

Sealey Group, Kempson Way, Suffolk Business Park, Bury St Edmunds, Suffolk. IP32 7AR



01284 757500



01284 703534



sales@sealey.co.uk



www.sealey.co.uk