

Thank you for purchasing a Sealey Product. Manufactured to a high standard this product will, if used according to these instructions and properly maintained, give you years of trouble free performance.

**IMPORTANT:** PLEASE READ THESE INSTRUCTIONS CAREFULLY. NOTE THE SAFE OPERATIONAL REQUIREMENTS, WARNINGS AND CAUTIONS. USE THIS PRODUCT CORRECTLY AND WITH CARE FOR THE PURPOSE FOR WHICH IT IS INTENDED. FAILURE TO DO SO MAY CAUSE DAMAGE AND/OR PERSONAL INJURY AND WILL INVALIDATE THE WARRANTY. PLEASE KEEP INSTRUCTIONS SAFE FOR FUTURE USE.

### 1. SAFETY INSTRUCTIONS

- ❑ **WARNING! DO NOT** use the wrench if damaged. Maintain the wrench in good condition and replace any damaged or worn parts. Use *genuine parts only*. *Unauthorised parts may be dangerous and will invalidate the warranty.*
- ✕ Ensure all workshop safety rules, regulations and conditions are complied with when using the wrench.
- ✓ Maintain correct balance and footing. Ensure the floor is not slippery and wear non-slip shoes.
- ✓ The work area should be clean, well lit and free from unnecessary clutter.
- ✓ Keep children and unauthorised persons away from the working area.
- ✓ Ensure that the vehicle you are working on is properly supported on axle stands or a hoist so as to resist the turning force applied to the wheel bearing lock nut.

### 2. INTRODUCTION AND SPECIFICATION

Made from high quality Chrome Vanadium steel for added strength and durability. Universal fitting, suitable for removing adjustable wheel bearing lock nuts found on commercial vehicles. Use with hexagonal and octagonal lock nuts and those with and without locating pins. Use with 3/4" or 1/2" breaker bar. Supplied with easy to follow instructions in carry case.

**SPECIFICATION. . . Model no. SX250**  
 Max torque . . . . . 500ft.lb  
 Pin Ø . . . . . Ø6, Ø8, Ø10mm  
 Capacity (Oct) 49-143mm across flats  
 Capacity (Hex) 49-135mm across flats

### 3. OPERATION

- 3.1 Before first use lubricate all threads.
- 3.2 Turn the thread engagement screw (X) anticlockwise to disengage the upper thread.
- 3.3 Open or close the jaws by turning knurled adjusting knob (6) until the jaws are approximately the correct distance apart. Place the jaws over the lock nut and close them down onto the nut.
- 3.4 Engage the upper thread by turning the thread engagement screw clockwise until you feel it make contact with the thread. Do not screw it down hard as this will lock the upper thread movement.
- 3.5 Turn the upper thread driver (4) clockwise to lock the jaws. This movement takes the play out of the assembly and angles the jaws slightly inwards at the same time.
- 3.6 To loosen the lock nut use a 1/2" or 3/4" breaker bar. To tighten the locknut use a torque wrench to tighten to the manufacturers stated specification. **Do not use with an impact wrench.**
- 3.7 Where needed, the wrench can be used with the appropriate size pins screwed into the jaws for those lock nuts with suitable location holes.

### 4. SPARE PARTS

01	SX250.01	No.01 JAW
02	SX250.02	No.02 JAW
03	SX250.03	THREAD
04	SX250.04	HEXAGON DRIVER AND PIN
05	SX250.05	THREAD
06	SX250.06	ROTATOR KNOB
07	SX250.07	3/4" ADAPTOR
08	SX250.08	1/2" F X 3/4" M ADAPTOR
09	SX250.09	8MM PIN
10	SX250.10	6MM PIN
11	SX250.11	10MM PIN

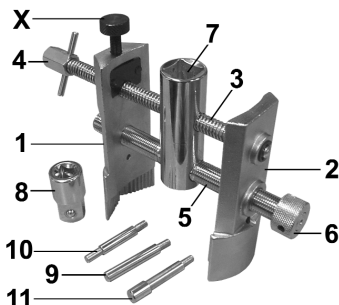

**NOTE:** It is our policy to continually improve products and as such we reserve the right to alter data, specifications and component parts without prior notice. **IMPORTANT:** No liability is accepted for incorrect use of this equipment. **WARRANTY:** Guarantee is 12 months from purchase date. proof of which will be required for any claim. **INFORMATION:** Call us for a copy of our latest catalogue on 01284 757525 and leave your full name and address including your postcode.