



130A PORTABLE MIG WELDER

MODEL NO: SUPERMIG130.V2

Thank you for purchasing a Sealey product. Manufactured to a high standard, this product will, if used according to these instructions, and properly maintained, give you years of trouble free performance.

IMPORTANT: PLEASE READ THESE INSTRUCTIONS CAREFULLY. NOTE THE SAFE OPERATIONAL REQUIREMENTS, WARNINGS & CAUTIONS. USE THE PRODUCT CORRECTLY AND WITH CARE FOR THE PURPOSE FOR WHICH IT IS INTENDED. FAILURE TO DO SO MAY CAUSE DAMAGE AND/OR PERSONAL INJURY AND WILL INVALIDATE THE WARRANTY. KEEP THESE INSTRUCTIONS SAFE FOR FUTURE USE.



Refer to instructions



Wear a welding mask



Wear eye protection



Wear protective gloves



Wear safety footwear



Wear protective clothing



Warning! Hot surfaces



Breathing welding fumes can be hazardous to your health.



Arc rays can burn eyes and injure skin.



Electric shock from welding electrodes can kill.



Electromagnetic fields can cause pacemaker malfunction.



Welding sparks can cause explosions or fire.

1. SAFETY

1.1. ELECTRICAL SAFETY

- ❑ **WARNING!** It is the user's responsibility to check the following:

Check all electrical equipment and appliances to ensure that they are safe before using. Inspect power supply leads, plugs and all electrical connections for wear and damage. Sealey recommend that an RCD (Residual Current Device) is used with all electrical products. You may obtain an RCD by contacting your local Sealey Stockist.

If the product is used in the course of business duties, it must be maintained in a safe condition and routinely PAT (Portable Appliance Test) tested.

Electrical safety information, it is important that the following information is read and understood.

- 1.1.1. Ensure that the insulation on all cables and on the appliance is safe before connecting it to the power supply.
- 1.1.2. Regularly inspect power supply cables and plugs for wear or damage and check all connections to ensure that they are secure.
- 1.1.3. **Important:** Ensure that the voltage rating on the appliance suits the power supply to be used and that the plug is fitted with the correct fuse - see fuse rating in these instructions.

- * **DO NOT** pull or carry the appliance by the power cable.
- * **DO NOT** pull the plug from the socket by the cable.
- * **DO NOT** use worn or damaged cables, plugs or connectors. Ensure that any faulty item is repaired or is replaced immediately by a qualified electrician.

- 1.1.4. This product is fitted with a BS1363/A 13 Amp 3 pin plug.
If the cable or plug is damaged during use, switch the electricity supply and remove from use. Ensure that repairs are carried out by a qualified electrician.
Replace a damaged plug with a BS1363/A 13 Amp 3 pin plug. If in doubt contact a qualified electrician.
 - a) Connect the GREEN/YELLOW earth wire to the earth terminal 'E'.
 - b) Connect the BROWN live wire to the live terminal 'L'.
 - c) Connect the BLUE neutral wire to the neutral terminal 'N'.Ensure that the cable outer sheath extends inside the cable restraint and that the restraint is tight. Sealey recommend that repairs are carried out by a qualified electrician.

1.2. GENERAL SAFETY

- ▲ **DANGER!** Unplug the welder from the mains power supply before performing maintenance or service.
- ✓ Keep the welder and cables in good working order and condition. Take immediate action to repair or replace damaged parts.
- ✓ Use genuine parts and accessories only. Unapproved parts may be dangerous and will invalidate the warranty.
- ✓ Use an air hose to regularly blow out any dirt from the liner and keep the welder clean for best and safest performance.
- ✓ Check and spray the gas cup and contact tip regularly with anti-spatter spray, available from your Sealey stockist.
- ✓ Locate welder in a suitable work area. Ensure that the area has adequate ventilation as welding fumes are harmful.
- ✓ Keep work area clean, tidy and free from unrelated materials. Also ensure the working area has adequate lighting and that a fire extinguisher is at hand.
- ❑ **WARNING!** Use welding head shield to protect eyes and avoid exposing skin to ultraviolet rays given off by electric arc. Wear safety welding gauntlets.
- ✓ Remove ill fitting clothing, remove ties, watches, rings and other loose jewellery and contain long hair.
- ✓ Ensure the workpiece is correctly secured before welding.
- ✓ Avoid unintentional contact with the workpiece. Accidental or uncontrolled use of the torch may be dangerous and will wear the nozzle.
- ✓ Keep unauthorised persons away from the work area. Any persons working within the area must wear a protective head shield and gloves.
- ✓ Operators must receive adequate training before using the welder.

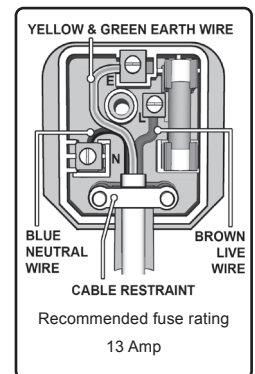

- ✓ Stand correctly keeping a good footing and balance, ensure the floor is not slippery and wear non-slip shoes.
 - ✗ **DO NOT** operate the welder if it or the cables are damaged and **DO NOT** attempt to fit any unapproved torches or other components to the welder.
 - ✗ **DO NOT** get welder wet or use in damp or wet locations or areas where there is condensation.
 - ▲ **DANGER! DO NOT** weld near flammable solids, liquids or gases and **DO NOT** weld containers or pipes which have held flammable materials. Avoid welding materials which have been cleaned with chlorinated solvents or welding near such solvents.
 - ✗ **DO NOT** stand welder on a metal workbench, car bodywork or similar.
 - ✗ **DO NOT** touch any live metal parts of the torch or electrode while the machine is switched on.
 - ✗ **DO NOT** pull the welder by the cable, or the torch. Protect cables from sharp or abrasive items, **DO NOT** bend, strain or stand on cables or leads. Protect from heat. Long lengths of slack must be gathered and neatly coiled. **DO NOT** place cables where they endanger others.
 - ✗ **DO NOT** touch the torch or workpiece immediately after welding as they will be very hot. Allow to cool.
 - ✗ **DO NOT** operate welder while under the influence of drugs, alcohol or intoxicating medication, or if tired.
 - ✓ When not in use store the welder in a safe, dry, childproof area.
- 1.3. GAS SAFETY**
- ✓ Store gas cylinders in a vertical position only and ensure the storage area is correctly secured.
 - ✗ **DO NOT** store gas cylinders in areas where the temperature may exceed 50°C. **DO NOT** use direct heat on a cylinder. Always keep gas cylinders cool.
 - ✗ **DO NOT** attempt to repair or modify any part of a gas cylinder or valve and **DO NOT** puncture or damage a cylinder.
 - ✗ **DO NOT** obscure or remove any official labels on a cylinder. Always check the gas identity before use. Avoid getting gas cylinders oily or greasy.
 - ✗ **DO NOT** lift a cylinder by the cap, guard or valve. Always keep caps and guards in place and close valve when not in use.

2. INTRODUCTION

Features heavy-duty high output transformer and forced-air cooling to ensure the highest level of performance. Contoured grip, non-live torch ensures a steadier weld bead. Includes mini gas regulator, spool of wire, contact tips 0.6 and 0.8mm and gas cup. Suitable for welding with CO₂, Argon or CO₂/Argon mix.

3. SPECIFICATION

Welding Current:	30-130A
Wire Capacity:.....	0.7-5kg
Duty Cycle:.....	100% @ 30A, 60% @ 45A, 40% @ 65A, 20% @ 80A
Cooling System:.....	Forced Air
Spot Welding Timer:.....	No
Gas Type:.....	CO ₂ , Argon, CO ₂ /Argon Mix
Torch:.....	2m Non-Live
Supply:.....	230V
Absorbed Power:.....	2.8kW
Case Size:.....	Compact

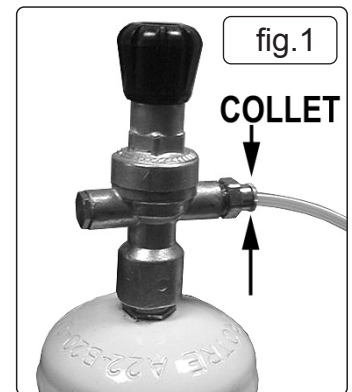

4. ASSEMBLY

- 4.1. CONNECTING THE GAS CYLINDER** (See Section 5.3 regarding gas types)
- 4.1.1. If the gas cylinder belt is not supplied fitted, thread it through the metal loops in the back panel just below the handle. Place the lower end of the cylinder into the metal hoop and fasten the belt around the cylinder as shown in fig.2.
- 4.1.2. Ensure that the regulator (fig.1) is closed (knob turned fully clockwise) and then screw it onto the cylinder (finger tight only). Once the regulator has opened the cylinder valve, indicated by the sound of gas escaping, screw it one full turn further, which is sufficient to seal the cylinder.
- ☐ **WARNING!** Excessive tightening of the regulator will over-compress the sealing washer and allow the gas to leak.
- 4.1.3. Push the gas tube into the quick connector on the regulator (to remove tube, press collet in and pull the tube. (See fig.1). Leave the regulator closed until the welder is fully set up and you are ready to weld.
- 4.1.4. When you are ready to commence welding switch the machine on and turn the regulator knob halfway for approx. 2l/min, and all the way for a max. flow of approx. 4l/min.
- 4.1.5. Always remove the flow regulator after use if the machine is to be stored for some time.
- 4.2. FITTING THE WIRE REEL.** The welder is supplied with a mini spool of mild steel wire, but will accept spools of up to 5kg without modification.
- 4.2.1. Referring to fig.3, rotate the pressure knob (F) anti-clockwise and remove it from the threaded spindle together with the spring (E) and the top disc (D). Small reels of wire will run on the spindle itself. The larger 5kg wire reel will run on the larger diameter flange at the base of the reel spindle (A). Place the wire reel (C) onto the spindle ensuring that the wire withdraws from the top of the spool in a forwards direction towards the wire feed unit. Place the plastic top disc (D) over the end of the spindle followed by the reel spring (E). Thread the pressure knob (F) onto the end of the spindle and screw it down clockwise until the spring is partially compressed. The reel take off pressure should be set to provide a mild braking effect to prevent overrun where loose coils of wire form on the reel. **DO NOT** overtighten this knob as too much braking will conflict with the wire tension set on the wire drive unit.
- 4.2.2. Unscrew the wire feed pressure knob and lift the wire feed lever up to the right (fig. 4).
- 4.2.3. Straighten about 40-50mm of spool wire (**DO NOT** allow wire to uncoil) and check that the wire end is smooth and free from burrs.



- Gently push wire through the plastic guide and through the 6 or 8mm roller groove and into the wire liner as indicated in fig.4
- 4.2.4. Hinge down the tension arm and secure with the wire feed knob (fig.5). (See section 4.4 re; wire tension).

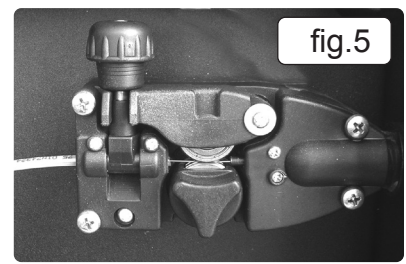
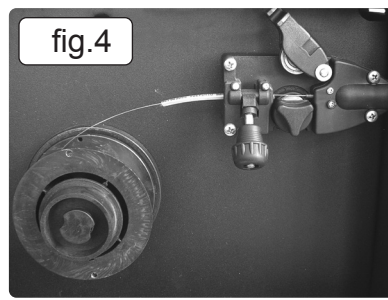
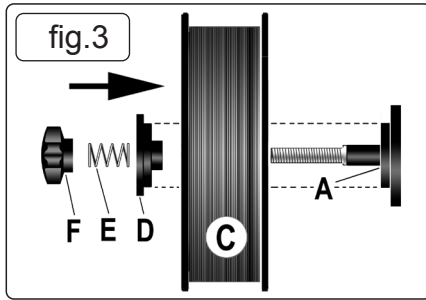

4.3. FEEDING THE WIRE THROUGH TO THE TORCH.

- ✗ **DO NOT** touch the torch immediately after welding as it will be hot. Allow to cool and wear protective gloves.
- 4.3.1. Remove gas cup and contact tip from end of torch as follows:
 - a) Take torch in left hand with the torch tip facing to the right and grasp gas cup with your right hand.
 - b) Turn gas cup clockwise only and pull cup out to the right (fig.6).
- ☐ **WARNING! DO NOT turn gas cup anti-clockwise, as this will damage the internal spring.**
- c) Unscrew the copper contact tip (right-hand thread) to remove.
- 4.3.2. Check welder is switched off "O", (I/O switch, fig.8) and that the earth clamp is away from the torch tip. Connect the welder to the mains power supply and set the current switches (Max/Min and I/II switches, fig.8) to 'Min 1'.
- 4.3.3. Set the wire speed knob to position 5 or 6 (fig.8) (the higher the number the faster the speed).
- 4.3.4. Switch the welder on "I", keep the torch cable as straight as possible and press the torch switch. The wire will feed through to the torch.
- 4.3.5. When wire has fed through, switch welder off and unplug from mains.
- 4.3.6.
 - a) Thread contact tip over wire and screw into place.
 - b) Grasp gas cup in right hand, push onto torch head and turn clockwise only.
- ☐ **WARNING! DO NOT** turn gas cup anticlockwise, as this will damage the internal spring.
- 4.3.7. Cut wire so that it is protruding approximately ¼" from the tip.

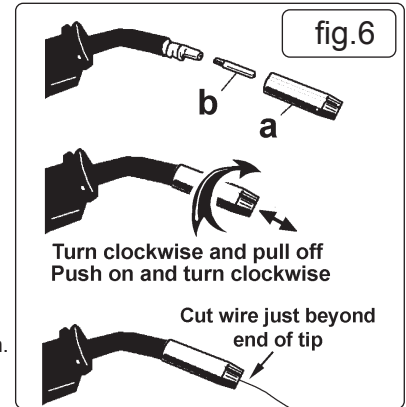

4.4. SETTING WIRE TENSION

- IMPORTANT:** Too little or too much tension will cause erratic wire feed and result in poor welding.
- 4.4.1. Tension between rollers is checked by slowing down the wire between your fingers. If top feed roller skids the tension is correct. Use as low a tension as possible, too high a tension will deform the wire and result in a blown fuse.

5. WELDING PRINCIPALS

5.1. MIG/MAG WELDING

Welding wire is automatically fed through an insulated liner to the tip of the torch. The torch consists of a switch, liner, gas hose, and control cable. The switch activates the wire feed roller and the gas flow. Releasing the switch stops wire feed and gas flow. The weld current is transferred to the electrode (the wire) from the contact tip at the torch end. Four settings control the current to the electrode. Settings are Min/1 = low, then Min/2, Max/1 and Max/2 = high. Wire speed must be adjusted according to current output. The higher the current the faster the wire speed. A gas cup fits over the contact tip to direct gas flow towards the weld, ensuring that the arc welding process is shielded from oxidation. The shielding gas also assists heating of the weld. The torch is connected to the positive side of a DC rectifier, and the negative clamp is attached to the workpiece.

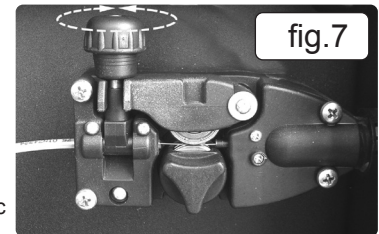

5.2. PREPARATION FOR WELDING

IMPORTANT! BEFORE YOU COMMENCE, MAKE SURE THE MACHINE IS SWITCHED OFF AT THE MAINS. IF WELDING A CAR, DISCONNECT THE BATTERY OR FIT AN ELECTRONIC CIRCUIT PROTECTOR. ENSURE THAT YOU READ, UNDERSTAND AND APPLY THE SAFETY INSTRUCTIONS IN SECTION 1.

- 5.2.1. To ensure a complete circuit, the negative lead must be securely attached to the workpiece, close to the weld area. Best connection is obtained by grinding the point of contact on the workpiece before connecting the clamp.
- 5.2.2. The weld area must be free of paint, rust, grease, etc.

5.3. GAS TYPES AND THEIR USE

Welding mild steel with CO₂ gas is appropriate for most welding tasks where spatter and high build-up of weld do not pose a problem.

To achieve a spatter free and flat weld however, requires an Argon/CO₂ mixture.

- 5.3.1. To weld aluminium use: ✓Argon Gas ✓0.8mm Contact Tip ✓0.8mm Aluminium Wire (MIG/2/ KAL08).

- 5.3.2. The following table is an estimated duration of cylinders based on a flow rate of 2 litres per minute. Actual duration will be dependant upon various job conditions including the operator's welding technique. All times are therefore approximate.

Disposable cylinders: (CO₂) CO₂/100 390g = 1-1/4hours. (CO₂) CO₂/101 600g = 2 hours.

(Argon) MIG/ARG/100 300g = 1hour. (CO₂/Argon Mix) MIG/MIX/100 300g = 1 hour.

Note: When comparing prices, always check fill weights.



5.4. THERMAL PROTECTION

Should the welder become overheated due to prolonged use beyond the stated duty cycle the thermal protection will cause the welder to cut out and the orange light on the front panel will illuminate. Wait for fifteen minutes for the welder to cool down at which time it will reconnect automatically.

6. RATING PLATE

On the front of the welder is the ratings plate, giving the following data:

- 1 - The standard relating to the safety and construction of arc welding and associated equipment.
- 2 - Inverter-transformer-rectifier.
- 3 - Welding with a continuous flow of welding wire.
- 4 - Single-phase AC supply.
- 5 - Rating of internal protection provided by casing.
- 6 - Output
 - U₀: Maximum open-circuit voltage.
 - I₂, U₂: Current and corresponding voltage.
 - X: Welding ratio based on a 10 minute cycle. 20% indicates 2 minutes welding and 8 minutes rest, 100% indicates continuous welding.
- 7 - Mains Supply
 - U₁: Rated supply voltage and frequency.
 - I_{max}: Maximum current.
 - I_{1eff}: Maximum effective current.
- 8 - Serial Number. Specifically identifies each welder.

MODEL No. SUPERMIG130		NO. 07031320147		8
1-		EN 60974 - 1		1
3		40A/16V ~ 80A/18V		
U ₀ = 27 V		X	20 %	50 %
		I ₂	80 A	55 A
		U ₂	18 V	16.7 V
4		U ₁ = 230 V	I _{max} = 12 A	I _{1eff} = 5.4 A
5				
		IP21S		

7. MAINTENANCE

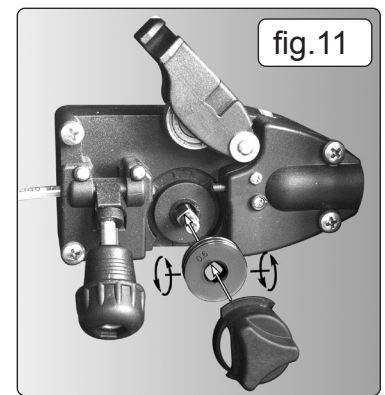
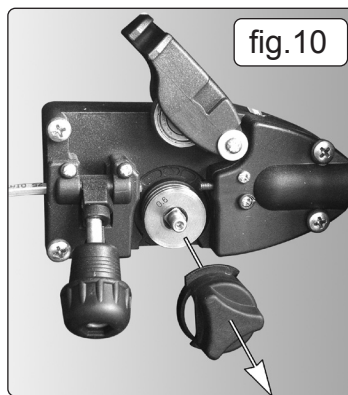
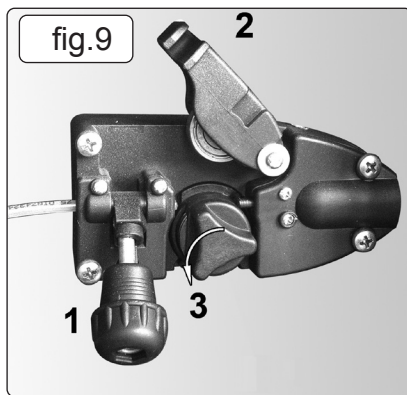

▲ **DANGER!** Unplug the welder from the mains power supply before performing maintenance or service.

- 7.1. **WIRE FEED UNIT:** Check the wire feed unit at regular intervals. The feed roller wire guide plays an important part in obtaining consistent results. Poor wire feed affects welding. Clean the rollers weekly, especially the feed roller groove, removing all dust deposits.
- 7.2. **TORCH:** Protect the torch cable assembly from mechanical wear. Clean the liner from the machine forwards by using compressed air. If the liner is blocked it must be replaced.
- 7.3. **TURNING FEED ROLLER: IMPORTANT:** Turn the feed roller to suit the wire size. There are two grooves on the feed roller, 0.6mm and 0.8mm. Always have the groove that is being used on the outside of the roller (nearest to you). To turn the feed roller first loosen the wire tension knob and move it into its down position (see fig.9-1) then move the tensioning roller assembly to its up position (see fig.9-2). Take hold of the triangular knob on the roller retainer and rotate it 90° anti-clockwise to release it as shown in fig.9.3. Now pull the roller retainer off the drive spindle to reveal the roller as shown in fig.10. Pull the roller off the drive spindle, flip it over and put it back on the drive spindle. (See fig 11) The groove size you require should now be visible on the face of the roller. Push the roller retainer back onto the drive spindle with the opening facing left. Ensure that the flanges at the base of the retainer, seat fully into the circular recess in the main moulding and then rotate the retainer through 90° to lock it in place.
- 7.4. **CONTACT TIP** (to remove tip follow steps in 4.3). The contact tip is a consumable item and must be replaced when the bore becomes enlarged or oval. The contact tip **MUST** be kept free from spatter to ensure an unimpeded flow of gas.
- 7.5. **GAS CUP** (to remove cup follow steps in 4.3). The gas cup must also be kept clean and free from spatter. Build-up of spatter inside the gas cup can cause a short circuit at the contact tip which will result in either the fuse blowing on the printed circuit card, or expensive machine repairs. To keep the contact tip free from spatter, we recommend the use of an anti-spatter spray.
- 7.6. **REPLACING WIRE LINER:** A worn or damaged wire liner will seriously affect the performance of the welder and should be immediately replaced. First wind the wire back onto the spool and secure it. Remove the four screws securing the torch cable clamp to the wire feed unit (fig.12) and take off the clamp. Undo the torch case (fig.13) and pull the wire liner from insulation block. Pull out the liner from the torch cable and insert the new one. Reverse the process to re-assemble. Ensure the liner is fully inserted into the torch insulation block and reassemble the torch. Trim the other end of the liner as close to the feed roller as possible. Replace the torch cable clamp.
- 7.7. **REPLACING GEARS:** An inexperienced welder can allow spatter to build up in the tip and shroud. In severe cases this can block the wire feed causing gear damage in the wire drive. To check if the gears are worn depress the button on the torch with the set

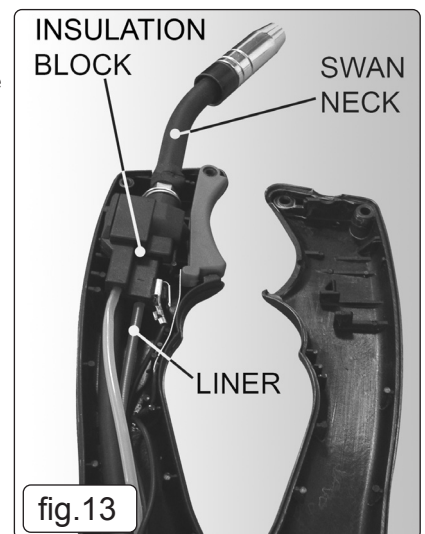
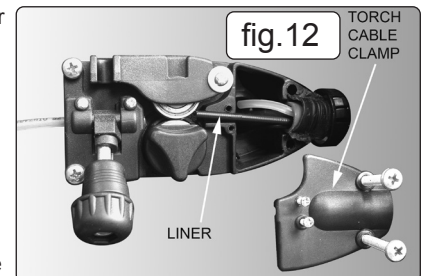

switched on. If the gears are worn, a grating sound will be heard coming from the wire feed motor and you may also observe the feed roller vibrating instead of rotating smoothly. In this case, open the gearbox, remove the worn or damaged gears and replace with new ones.

8. TROUBLESHOOTING

PROBLEM	POSSIBLE CAUSE	REMEDY
Weld current interrupted	Overheating protection activated due to overload	Protection automatically resets when transformer has cooled (approx. 15 min).
No weld current, fuse blowing in 13amp plug	Rectifier blown	Replace rectifier.
No weld current	Bad connection between clamp and workpiece Break in earth lead Break in torch lead	Clean or grind contact surface and weld area. Repair or replace earth lead. Repair or replace.
Feed motor not working	Gear damaged or worn Motor defective	Replace gears (Section 7). Replace motor (Contact service agent).
Wire does not feed, feed roller rotates	Pressure roller improperly adjusted Dirt, copper, dust, etc. have collected in torch liner Gas cup (nozzle) or tip defective Deformed wire	Adjust tension. Clean the liner from the machine forward. Use compressed air. If too much dirt, replace the liner (Section 7). Replace gas cup (nozzle) and/or tip (Section 7). Check roller tension (Section 4).
Wire feeds unevenly	Dirt, etc. in liner Gas cup (nozzle) or tip defective Gas cup (nozzle) spattered Feed roller groove clogged Feed roller groove deformed Pressure roller tension incorrect	Clean the liner from the machine forward using compressed air. Replace gas cup (nozzle) and/or tip (Section 7). Clean or replace gas cup (nozzle) (Section 7). Clean feed roller (Section 7). Replace feed roller (Section 7). Adjust tension (Section 4).
Unstable arc	Incorrect settings Impurities in weld area Worn or defective gas cup (nozzle)	Check settings (Section 5). Clean and/or grind workpiece (Section 5). Replace gas cup (nozzle) (Section 7).
Porous weld	No gas Gas cup clogged Draft blowing away shielding gas Rusty/dirty joints Torch too far from, or at wrong angle to, workpiece Gas leak	Open gas cylinder, regulate gas flow. Clean or replace cup (Section 7). Screen off welding site or increase gas flow. Clean or grind the workpiece (Section 5). Gas cup to workpiece should be 8-10mm. Torch angle approx 75°. Check hoses, connections and torch assembly (Section 7).
Wire sticking in gas cup (nozzle)	Worn or defective gas cup (nozzle) Wire deformed Wire speed too slow	Replace gas cup (nozzle) (Section 7). Check roller tension (Section 4). Increase wire speed.
Irregular weld bead	Torch incorrectly held Wire weaving in weld pool	Use correct torch angle. Check roller tension and adjust (Section 4).
Weld bead too narrow and raised	Weld current too low Weld speed too fast	Increase power and wire speed (Section 5). Move torch slower and weave a little more.
Weld bead too wide	Weld current too high Weld speed too slow Arc too long	Decrease current and wire speed (Section 5). Move torch faster and weave less. Bring torch closer to workpiece.
Poor penetration	Weld current too low Arc too long	Increase current and wire speed (Section 5). Bring torch closer to workpiece.
Excessive penetration	Weld current too high Weld speed too slow Incorrect distance of torch to workpiece	Decrease current and wire speed (Section 5). Move torch faster. Torch distance should be 8-10mm.

9. CONSUMABLES

Part No.	Description	Pack Qty
MIG955.	GAS CUP	3pc
MIG956.	Contact Tip 0.6mm	5pc
MIG957.	Contact Tip 0.8mm	5pc
MIG927.	Contact Tip 0.8mmAlly	2pc
MIG928.	Contact Tip 1.0mmAlly	2pc
C02/100	Disposable 390g Gas Cylinder CO ₂	
C02/101	Disposable 600g Gas Cylinder CO ₂	
MIG/MIX/100	Disposable CO ₂ /Argon mix	
MIG/ARG/100.	Disposable 300g Argon	



ENVIRONMENT PROTECTION

Recycle unwanted materials instead of disposing of them as waste. All tools, accessories and packaging should be sorted, taken to a recycling centre and disposed of in a manner which is compatible with the environment. When the product becomes completely unserviceable and requires disposal, drain any fluids (if applicable) into approved containers and dispose of the product and fluids according to local regulations.



WEEE REGULATIONS

Dispose of this product at the end of its working life in compliance with the EU Directive on Waste Electrical and Electronic Equipment (WEEE). When the product is no longer required, it must be disposed of in an environmentally protective way. Contact your local solid waste authority for recycling information.

Note: It is our policy to continually improve products and as such we reserve the right to alter data, specifications and component parts without prior notice.

Important: No Liability is accepted for incorrect use of this product.

Warranty: Guarantee is 12 months from purchase date, proof of which is required for any claim.

Sealey Group, Kempson Way, Suffolk Business Park, Bury St Edmunds, Suffolk. IP32 7AR



01284 757500



01284 703534



sales@sealey.co.uk



www.sealey.co.uk