

Thank you for purchasing a Sealey product. Manufactured to a high standard this product will, if used according to these instructions and properly maintained, give you years of trouble free performance.



**IMPORTANT: PLEASE READ THESE INSTRUCTIONS CAREFULLY. NOTE THE SAFE OPERATIONAL REQUIREMENTS, WARNINGS AND CAUTIONS. USE THIS PRODUCT CORRECTLY AND WITH CARE FOR THE PURPOSE FOR WHICH IT IS INTENDED. FAILURE TO DO SO MAY CAUSE DAMAGE AND/OR PERSONAL INJURY AND WILL INVALIDATE THE WARRANTY. PLEASE KEEP INSTRUCTIONS SAFE FOR FUTURE USE.**

## 1. SAFETY INSTRUCTIONS

- ✓ Familiarise yourself with the application, limitations and potential hazards peculiar to the spray Gun.
- ☐ **WARNING!** Disconnect the spray gun from the air supply before changing accessories, servicing or performing any maintenance.
- ✓ Maintain the spray gun in good condition. (Use an authorised service agent).
- ✓ Replace or repair damaged parts. *Use recommended parts only.*  
*Unauthorised parts may be dangerous and will invalidate the warranty.*
- ✓ Keep the spray gun clean for best and safest performance.
- ✓ Ensure that the compressed air system can supply the spray gun air consumption (4.2cfm).
- ✓ Wear approved safety respiratory protection and safety eye goggles.
- ✓ If spraying isocyanate based finisher, wear approved respirator/clean air breathing apparatus and cover exposed skin with latex gloves and an impervious hooded coverall.
- ✓ Remove ill fitting clothing. Remove ties, watches, rings and other loose jewellery and tie back long hair.
- ✓ Locate the spray gun in a suitable work area. Keep area clean and tidy and free from unrelated materials and ensure that there is adequate ventilation and lighting.
- ✓ Keep children and unauthorised persons away from the work area.
- ✓ When not in use, ensure that the air supply is turned off.
- ✓ Avoid unintentional operation of spray gun.
- ✗ DO NOT point spray gun at yourself, other persons or animals.
- ✗ DO NOT direct air from the air hose at yourself, other persons or animals.
- ✗ DO NOT carry the spray gun by the hose, or yank the hose from the air supply.
- ✗ DO NOT exceed the maximum air pressure of 35psi.
- ✗ DO NOT use the spray gun for any purpose other than that for which it is designed.
- ✗ DO NOT allow untrained persons to operate the spray gun.
- ✗ DO NOT get the spray gun wet or use in damp or wet locations or in areas where there is condensation.
- ✗ DO NOT operate the spray gun if any parts are missing or damaged as this may cause failure and/or personal injury.
- ✓ When not in use, disconnect the spray gun from the air supply, clean thoroughly and store safely.



## 2. INTRODUCTION & SPECIFICATIONS

Constant bleed type spray gun for use on simple applications. Supplied with a aluminium suction feed pot. Suitable for use with waterborne paints.

Standard set-up: . . . . . 1.3mm  
 Air pressure: . . . . . 35psi  
 Air consumption: . . . . . 4.2cfm

### 3. AIR SUPPLY CONNECTION

Recommended supply system is shown below (fig.1).

- 3.1. Ensure that the spray gun trigger is in the "off" position before connecting to the air supply.
- 3.2. You will require an air pressure of 35psi and an air flow according to the specification.
  - **WARNING!** Ensure that the air supply is clean and does not exceed 35psi while operating the spray gun.  
Too high an air pressure and/or unclean air will shorten the product life, due to excessive wear, and may cause damage and/or personal injury.
- 3.3. Drain the air tank daily. Water in the air line will damage the spray gun and invalidate your warranty.
- 3.4. Clean compressor air inlet filter weekly.
- 3.5. Line pressure should be increased to compensate for unusually long air hoses (over 8 metres). The minimum hose diameter should be 1/4" I.D. and fittings must have the same inside dimensions.
- 3.6. Keep hose away from heat, oil and sharp edges. Check hoses for wear, and make certain that all connections are secure.

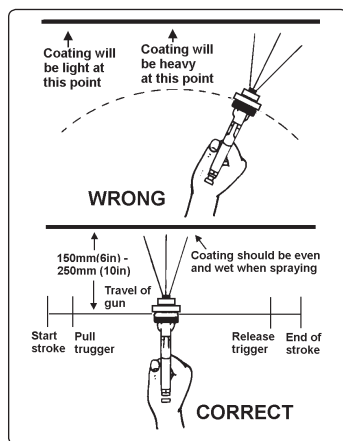
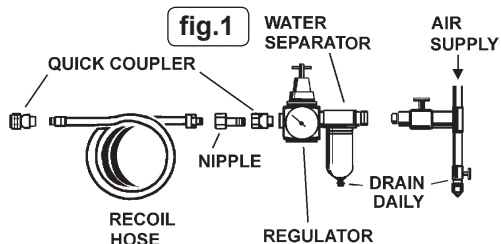



### 4. OPERATING INSTRUCTIONS

- 4.1. For best results, handle the gun correctly. It should be held perpendicular to the surface being sprayed and moved parallel to it. Start the stroke before squeezing the trigger and release the trigger before finishing the stroke. This will give more accurate control of the gun and the material (see right).
- 4.2. Spray from a distance of 150mm (6") to 250mm (10"), depending on the material and the atomizing pressure. The material deposited should always be even and wet. Each stroke must overlap the preceding stroke to obtain a uniform finish. To reduce over-spray and obtain maximum efficiency, spray with the lowest possible atomizing air pressure.
- 4.3. **Controlling the fluid volume:** To control the volume of fluid dispensed use the regulation screw. (fig.2.1). To increase the volume of fluid turn the screw anti-clockwise. To decrease the volume of fluid turn the screw clockwise. There is no on gun air pressure adjustment as this is automatically increased as the fluid volume is increased.
- 4.4. **Controlling the spray pattern:** The SSG701 comes with two alternative air caps to give either a cone shaped spray pattern or a fan shaped pattern. Before changing air caps disconnect the gun from the air supply. Undo the air cap retaining ring (fig.2.2) and swap the air caps over. When using the fan pattern remember to rotate the air cap so that its dispensing slot is vertical. Retighten the air cap retaining ring.

## 5. CLEANING & MAINTENANCE

- 5.1 Disconnect the gun from the air supply before attempting any maintenance or cleaning.
- 5.2 **Flush the gun through with clean solvent immediately after use.** (Any delay may cause the nozzle and inner components to clog up.)
- 5.3 To maintain optimum performance, periodically disassemble those components directly in contact with the fluid and soak them in clean solvent for at least 10 minutes. Brush clean if necessary and dry.
- 5.4 If you need to probe the holes in the nozzles, be sure to use a tool that is softer than brass; do not use metal instruments.
- 5.5 Take extra care when reassembling parts after maintenance. Screw parts hand tight first to avoid cross-threading. If a part cannot easily be turned by hand, check that you have the correct part, or unscrew, realign and try again. **DO NOT** use excessive force when reassembling.
- 5.6 Use a solvent soaked rag and/or a bristle brush to wash accumulated paint from the outside of the gun.
- 5.7 Do not immerse the entire gun in solvent. This will cause lubricants to dissolve and packing to dry out. Dirty solvent may also clog the narrow passages in the gun.
- 5.8 Lubricate the gun daily with a light machine oil. Do not use lubricants containing silicone.

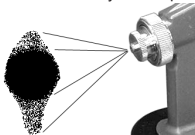
## 6. TROUBLESHOOTING

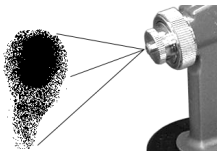
THE PROBLEM	THE CAUSE	THE SOLUTION
Poor atomization/heavy centre pattern 	Fluid flow is too high for the air pressure and flow.	<ol style="list-style-type: none"> <li>1. Increase air pressure by adjusting regulator at source of air supply (35psi max).</li> <li>2. Reduce fluid flow as described in section 4.3.</li> <li>3. Paint may be too thick. If so, dilute it.</li> </ol>
Heavy atomization, poor centre pattern 	Air pressure and flow too high for fluid flow.	<ol style="list-style-type: none"> <li>1. Reduce air pressure by adjusting regulator at source of air supply (35psi min).</li> <li>2. Increase fluid flow as described in section 4.3.</li> </ol>
Intermittent spray pattern 	Air entering the fluid supply.	<ol style="list-style-type: none"> <li>1. Tighten the connection between the gun and the cup.</li> <li>2. Tighten fluid nozzle with gun spanner.</li> <li>3. Check if cup vent hole is blocked.</li> <li>4. Check if cup is empty.</li> </ol>
Top heavy or bottom heavy pattern 	Possible paint build-up between fluid nozzle and air cap (A).	<ol style="list-style-type: none"> <li>1. Clean the air cap and the fluid nozzle.</li> <li>2. Check needle for damage.</li> </ol>

**NOTE:** It is our policy to continually improve products and as such we reserve the right to alter data, specifications and component parts without prior notice.

**IMPORTANT:** No liability is accepted for incorrect use of this product.

**WARRANTY:** Guarantee is 12 months from purchase date, proof of which will be required for any claim.

**INFORMATION:** For a copy of our latest catalogue and promotions call us on 01284 757525 and leave your full name and address, including postcode.



Sole UK Distributor, Sealey Group,  
Kempson Way, Suffolk Business Park,  
Bury St. Edmunds, Suffolk,  
IP32 7AR



01284 757500



www.sealey.co.uk



01284 703534



sales@sealey.co.uk