



PLATFORM SCAFFOLD TOWER EN 1004 MODEL NO: SSCL.1

PLATFORM SCAFFOLD TOWER EXTENSION PACK 2 EN1004-1 MODEL NO: SSCL.2

SCAFFOLD TOWER EXTENSION PACK 2 MODEL NO: SSCL3

SCAFFOLD TOWER EXTENSION PACK 4 MODEL NO: SSCL4

Thank you for purchasing a Sealey product. Manufactured to a high standard, this product will, if used according to these instructions, and properly maintained, give you years of trouble free performance.

IMPORTANT: PLEASE READ THESE INSTRUCTIONS CAREFULLY. NOTE THE SAFE OPERATIONAL REQUIREMENTS, WARNINGS & CAUTIONS. USE THE PRODUCT CORRECTLY AND WITH CARE FOR THE PURPOSE FOR WHICH IT IS INTENDED. FAILURE TO DO SO MAY CAUSE DAMAGE AND/OR PERSONAL INJURY AND WILL INVALIDATE THE WARRANTY. KEEP THESE INSTRUCTIONS SAFE FOR FUTURE USE.



Refer to instructions



Wear protective gloves



Wear head protection

A MINIMUM OF TWO PEOPLE ARE REQUIRED TO BUILD THIS TOWER

| | | | |
|--|---|--|--|
| | Allow 2 m between platforms when assembling and dismantling | | Do not climb on the outside of the mobile access and working tower |
| | Do not use a ladder or anything else to increase the height of the tower | | Do not suspend heavy objects from the mobile access and working tower |
| | Do not suspend the mobile access and working tower | | Do not create walkways between mobile access and working towers or other structures |
| | Do not lift the mobile access and working tower with mechanical equipment | | Do not move the mobile access and working tower when there are people or equipment on it |

| | | | |
|--|---|--|---|
| | Do not stand on an unsecured platform | | Maximum tilt when moving the tower |
| | Maximum tilt when working on the tower | | Maximum speed when moving the tower |
| | Maximum wind speed when working on the tower | | Respect the allowable loads for the platforms and the structure |
| | Keep within the working area. Do not lean over the edge | | Follow the rules for stabilizer assembly |
| | Do not position near live unprotected conductors For soft ground, ensure there is a profiled track | | |

1. SAFETY

- ✓ These instructions do not replace existing legislation which should be used as a reference.
- ✓ Respect allowable loads for the platforms and structure.
- ✓ Horizontal forces should not exceed 30Kg.
- ✓ Wind speed limit with stabilizers = 35 km/h.
- ✓ For wind speeds above 35 km/h: fasten down the mobile access and working tower.
- ✓ For wind speeds above 45 km/h: take down the mobile tower.
- ✗ **DO NOT** position the mobile tower near live unprotected conductors.
- ✓ Prohibit access to the equipment when it is positioned in areas accessible to the public.
- ✓ Ensure there is sufficient signage at the site in case of traffic and vehicles.
- ✓ Check that there are no aerial obstacles in the movement area.
- ✓ Mobile access and working towers should only be moved manually whilst on firm and even ground, and where there are no obstacles either on the ground or in the air. The speed at which the mobile tower is moved should not exceed a man's normal walking speed.
- ✓ The mobile access and working tower to be moved should not exceed 6m in height, and no-one should be on the equipment whilst it is being moved.
- ✓ Keep the stabilisers fixed on the mobile access and working tower whilst it is being moved. (The play between the support plates and the ground should be reduced to a minimum).
- ✓ The ground on which the mobile access and working tower is being moved should be able to support load lowering.
- ✓ For soft ground (loose soil, gravel, etc.), ensure there is a profiled track.
- ✓ Tower is moved with two people: the mobile access and working tower is "PUSHED" at a maximum height as specified by the manufacturer; it is not "PULLED".
- ✓ When the mobile access and working tower is left unattended, ensure that the stabilizers are positioned correctly, refer to steps 8 and 12, prevent all unauthorised access, and protect from harsh weather conditions
- ✓ Prevent all unauthorised access, and protect it from harsh weather conditions.
- ✓ Mobile towers are not designed to be covered in sheeting.
- ✓ Mobile towers complying with EN 1004-1 are not designed to be used as a means of peripheral protection.
- ✓ Mobile towers complying with EN 1004-1 are not designed to be used as a means of entering or exiting other structures, such as a staircase, for example.
- ✓ The instruction manual should be available at the site where the mobile tower is being used.
- ✓ The mobile access and working tower should only be used in accordance with this manual, and should not be modified in any way.
- ✓ Mobile access and working towers should only be used in accordance with national regulations.
- ✓ The mobile tower should be used intentionally as a means of accessing the working area.
- ✓ All components, tools and other necessary equipment to assemble the mobile tower should be available at the site.
- ✓ Before assembling the mobile access and working tower, the chosen site should be checked to identify and prevent hazards during its assembly, modification and dismantling, including, and without limitation:
 - Ground conditions;
 - The level of the slope;
 - Obstacles (on the ground or in the air);
 - Weather conditions;
 - Hazardous electrical phenomena.
- ✓ Assemble the mobile access and working tower according to the instructions in this manual for assembly and use.
- ✓ Ensure that all necessary split pins and bolts are firmly in place.
- ✓ Should only be erected and dismantled by personnel trained in assembling and using the mobile tower.
- ✓ User training courses are not a substitute for instruction manuals, but can complement them.
- ✓ Only original components, as specified in this manual, should be used.
- ✓ Damaged or faulty components should not be used.
- ✓ For assembling each element, refer to the respective previous diagrams.
- ✓ PPE (Personal Protective Equipment) must be worn for assembly and dismantling.
- ✓ Stabilizers must always be positioned at an angle; refer to the diagrams and the table in this manual.
- ✓ Two-person assembly is required.
- ✓ Different levels can be accessed from inside the mobile tower via the trap doors.
- ✓ Hauling up items to raise the height of the product can be done from the guard rail side once this has been installed.
- ✓ Hauling up tools or other items whilst the product is in use can be done through platform access trap doors.
- ✓ This product should only be used in accordance with the instruction manual.
- ✓ It is forbidden to:
 - Use a lifting beam, even a manual one, on the outside of the mobile tower.
 - Cover the mobile access and working tower in sheeting, even partially.
 - Increase the height of the tower above the authorised height.
 - Use components other than the ones that have been supplied and described in the parts list.
 - Use damaged parts.
 - Use a mobile access and working tower which has not been assembled vertically (tolerance: 1%).
 - Use a mobile access and working tower which has not been assembled according to the instructions in this manual.
 - Create a bridge between a mobile access and working tower and a building, or between two mobile towers.
 - Lean an access ladder against the mobile tower.
 - Jump on the platforms.
 - Use boards as a platform.
 - Access to the working platform from the outside.
 - Move the mobile access and working tower on ground which is sloped more than 3%.
 - Move the mobile access and working tower with a motor vehicle.
 - Move the mobile access and working tower in wind speeds above 35 km/h.
 - Move the mobile access and working tower when personnel or equipment are on it.
 - Lift the mobile access and working tower with a crane or bridge crane.

Keep the trap door blocked open.

- ✓ Mobile access and working towers designed in accordance with EN 1004-1 are not anchor points for fall arrest systems.
- ✓ Working on a platform is only allowed if there is a complete guard rail consisting of handrails, intermediate rails and toeboards.
- ✓ After assembly or modification, the following basic information should be displayed on the mobile access and working tower, and it should be clearly visible from the ground (on a label, for example):
 - The name and contact details of the person in charge;
 - Whether the mobile access and working tower is ready for use or not;
 - The load category and the uniformly distributed load value for the mobile access and working tower;
 - Whether the mobile access and working tower is solely intended for interior use only;
 - The assembly date.

1.1. LOAD STRUCTURE:

- ✓ Mobile access and working tower category III EN 1004-1
- ✓ Point load: 150 Kg on a single loaded platform
- ✓ Maximum allowable load on a single level: 2000 N/ m² (≈ 169 Kg) uniformly distributed on the platform
- ✓ 1 person per platform (see platform details above)
- ✓ Only the last platform should have a person on it, provided the load limits detailed above are respected!
- ✓ The use of stabilizers is compulsory for all mobile tower heights.

2. INTRODUCTION

SSCL.1: EN 1004-1 Approved Scaffold Tower System designed to meet the UK PASMA 3T standards. Robust aluminium frame unit with durable corrosion resistance. Heavy-duty platform with trapdoor for safe access to platform. Base working height is 2.6m and can be extended to multiple heights, check extension packs SSCL.2, SSCL3 and SSCL4 for full details. Unique design enables the unit to be quickly and easily folded down without tools for transportation or storage. 890mm Depth means unit will pass through most doorways even when partly erected. Hand rails for comfort and safety. Four large Ø125mm castors for easy mobility.

SSCL.2: Extension kit for Model No. SSCL.1, increases platform height to 1.6m and working height to 3.6m. Supplied with 2 x 1m ladder extensions and 1 x safety rail. Manufactured from robust aluminium with anodized finish for durable corrosion resistance.

SSCL3: Extension kit for Model No. SSCL.1, increases platform height to 3.3m and working height to 5.3m. Supplied with 2 x 2m ladders, 4 x safety rails, 2 x Ø35 Diagonal supports and 1 x Additional Platform with trapdoor. Manufactured from robust aluminium with anodized finish for durable corrosion resistance.

SSCL4: Extension kit for Model No. SSCL.1, SSCL.2 and SSCL3, increases platform height to 5.1m and working height to 7.1m. Supplied with 2 x 2m ladders, 4 x Ø35 diagonal supports. Manufactured from robust aluminium with anodized finish for durable corrosion resistance.

3. SPECIFICATION

Model No: SSCL.1
Depth: 890mm
Description: Base Pack
Capacity: 200kg/m²
Max. Platform Height: 0.6m
Max. Working Height: 1.6m
Width: 1750mm
Width with legs: 3084mm

Model No: SSCL.2
Depth: 890mm
Description: Extension Pack 2
Capacity: 200kg/m²
Max. Platform Height: 1.6m
Max. Working Height: 3.6m
Width: 1750mm
Width with legs: 3084mm
Note: Only when used with SSCL.1

Model No: SSCL3
Depth: 890mm
Description: Extension Pack 3
Capacity: 200kg/m²
Max. Platform Height: 3.3m*
Max. Working Height: 5.3m*
Width: 1750mm
Width with legs: 3084mm
Note: *only when used with SSCL.1 & SSCL.2

Model No: SSCL4
Depth: 890mm
Description: Extension Pack 4
Capacity: 200kg/m²
Max. Platform Height: 5.1m**
Max. Working Height: 7.1m**
Width: 1750mm
Width with legs: 3084mm
Note: ** only when used with SSCL.1, SSCL.2, SSCL.4

4. MODEL COMPOSITION

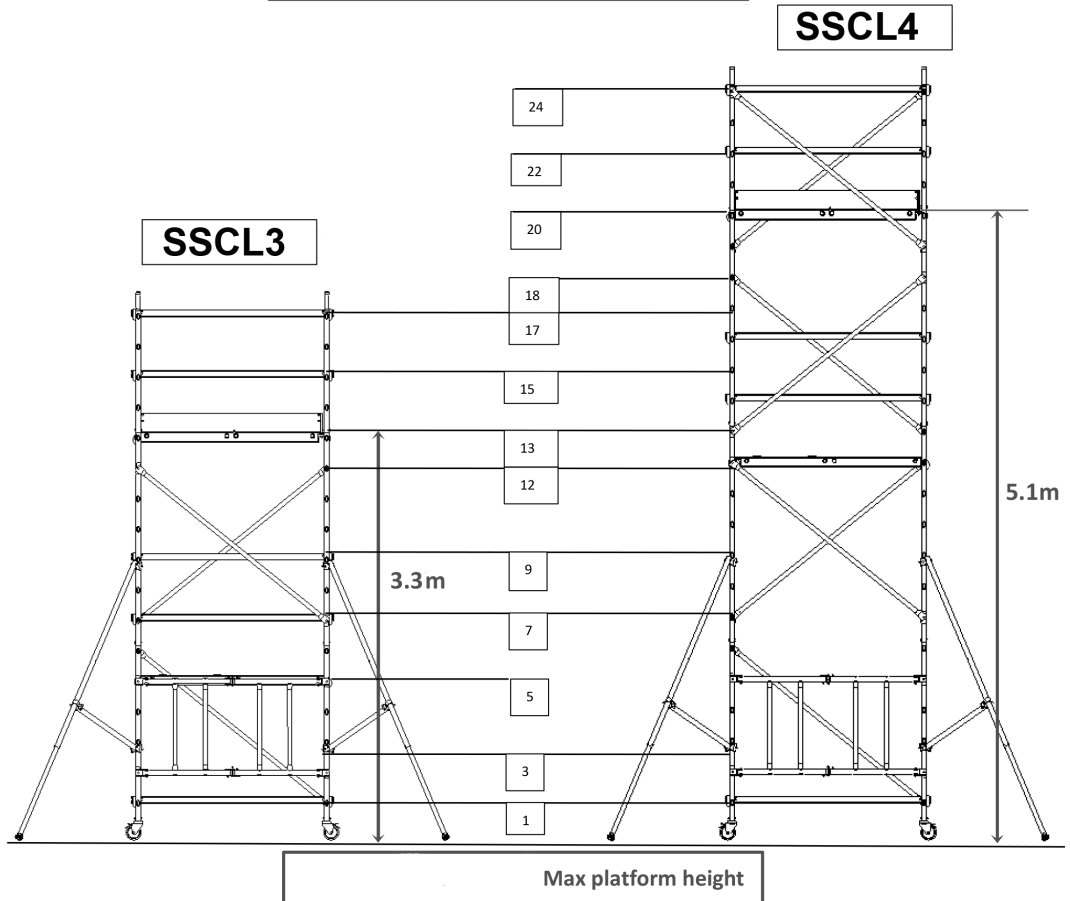
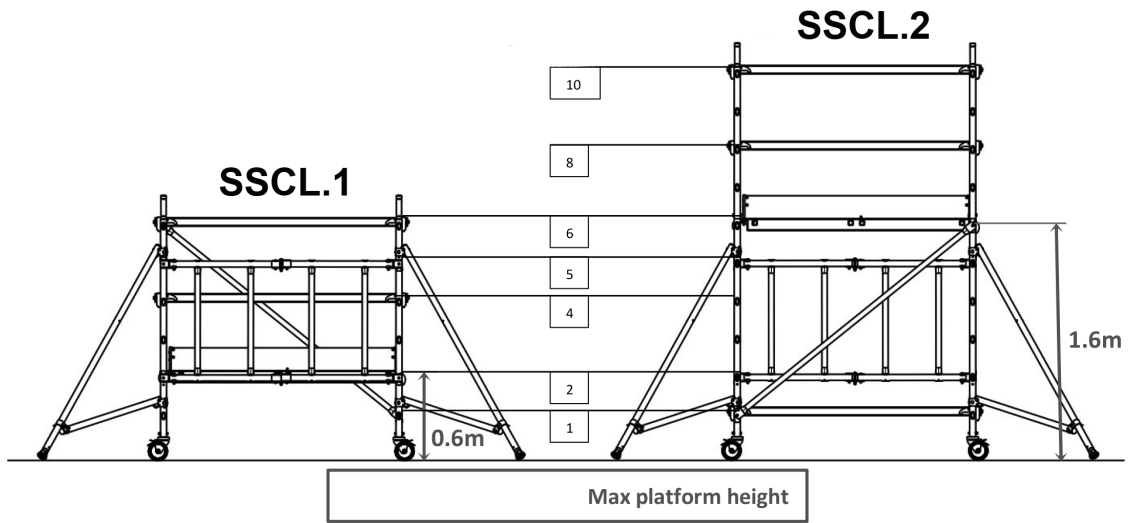

Platform height \neq working height - Adapt the platform height to the working area

5. CONTENTS

| No | Description | Weight kg |
|----|--------------|-----------|
| 1 | Base ladder | 5.9 |
| 2 | 1m ladder | 2.9 |
| 3 | 2m ladder | 4.7 |
| 4 | Folding base | 5 |
| 5 | Rail | 1.4 |
| 6 | Diagonal | 1.1 |
| 7 | Stabiliser | 2.7 |
| 8 | Platform | 9.2 |
| 9 | Toeboards | 5.7 |
| 10 | Wheels | |

SSCL.1

Contents:
 1 x Platform
 1 x Diagonal
 2 x Base Ladder
 1 x Folding Base
 4 x Rail
 1 x Toeboards

SSCL.2

Contents:
 2 x 1m Ladder
 1 x Rail

SSCL.3

Contents:
 2 x 2m Ladder
 4 x Rail
 2 x Diagonal
 1 x Platform

SSCL.4

Contents:
 2 x 2m Ladder
 4 x Diagonal

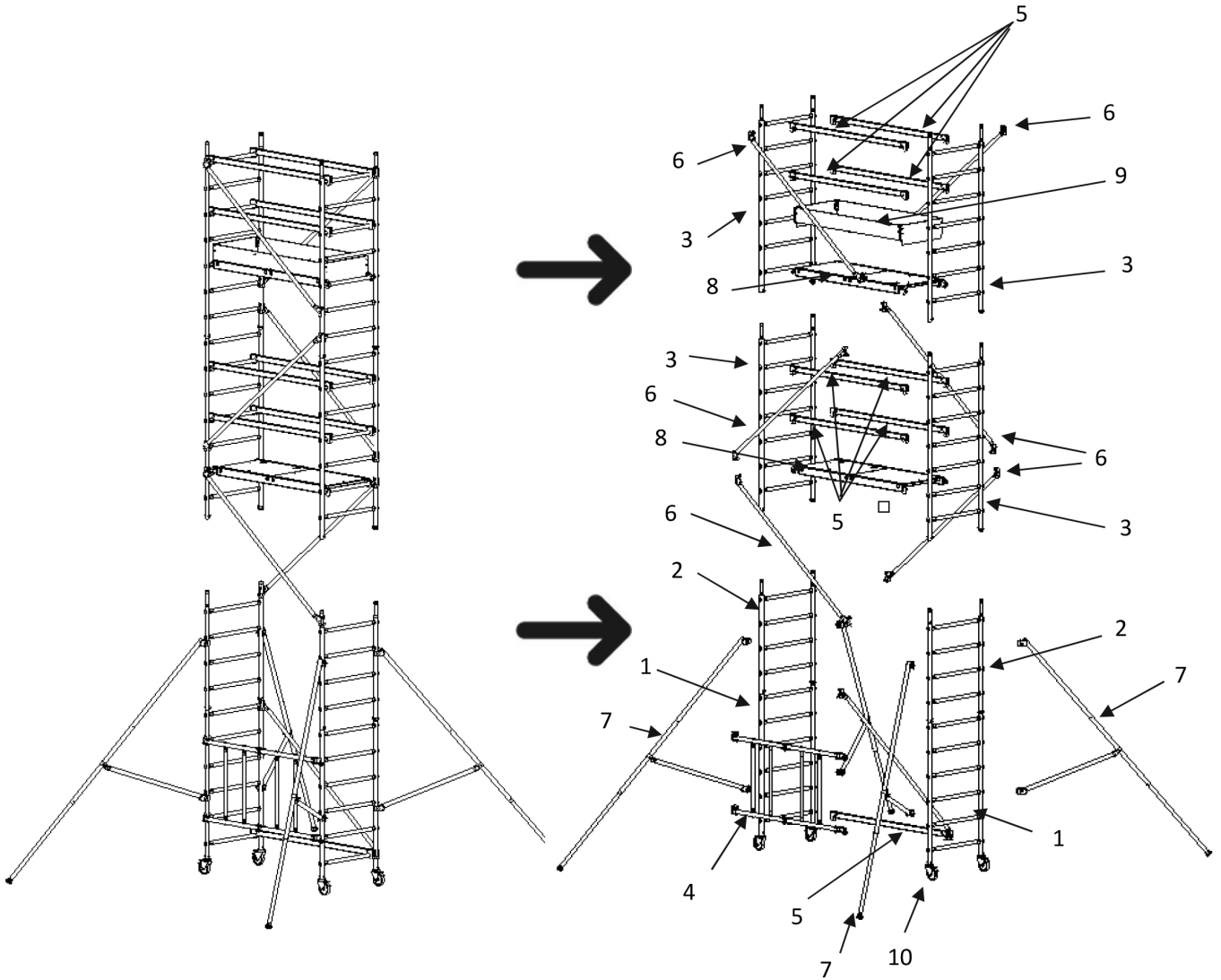

6. ASSEMBLY

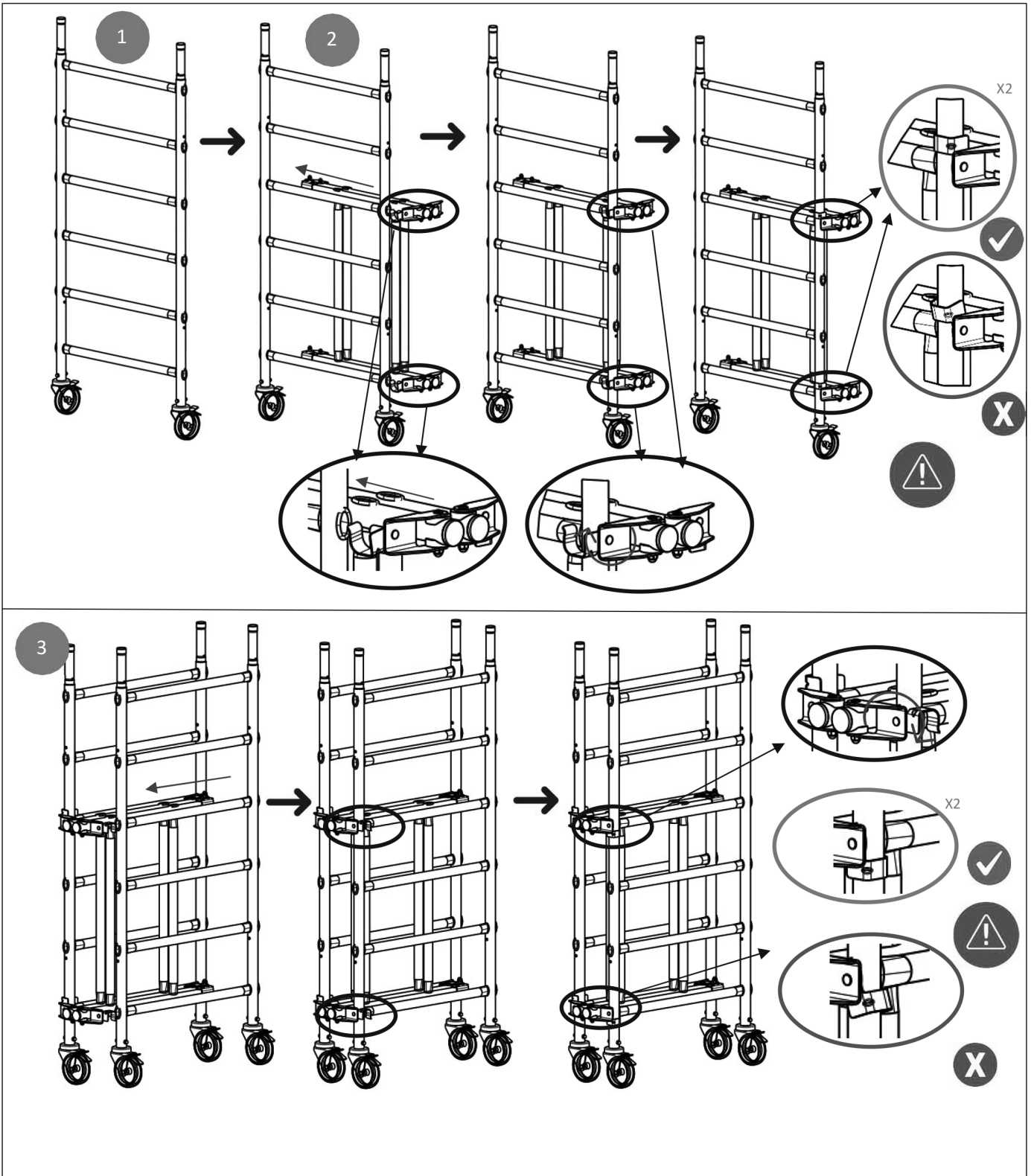

Unfolding the base

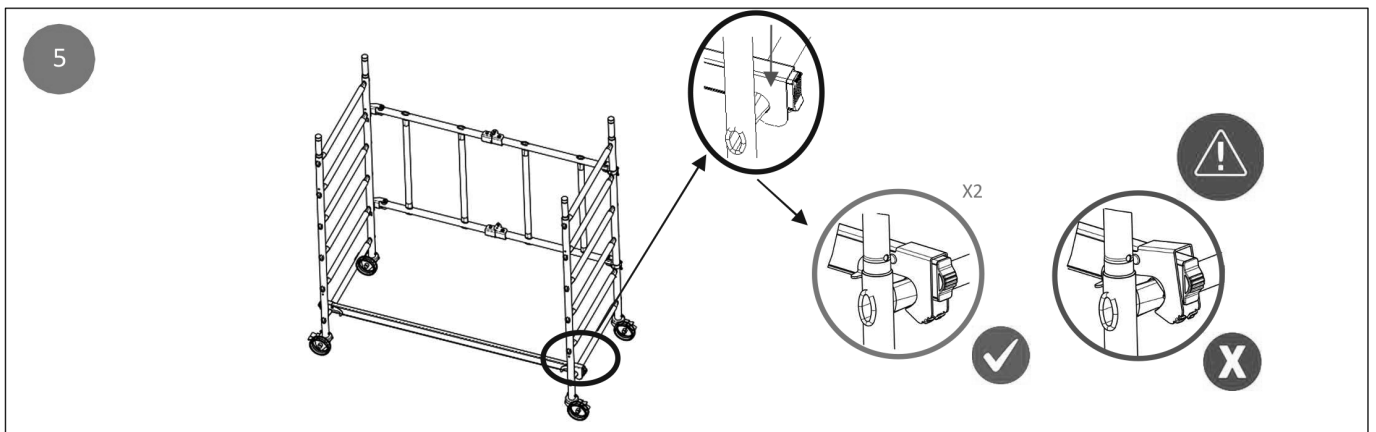
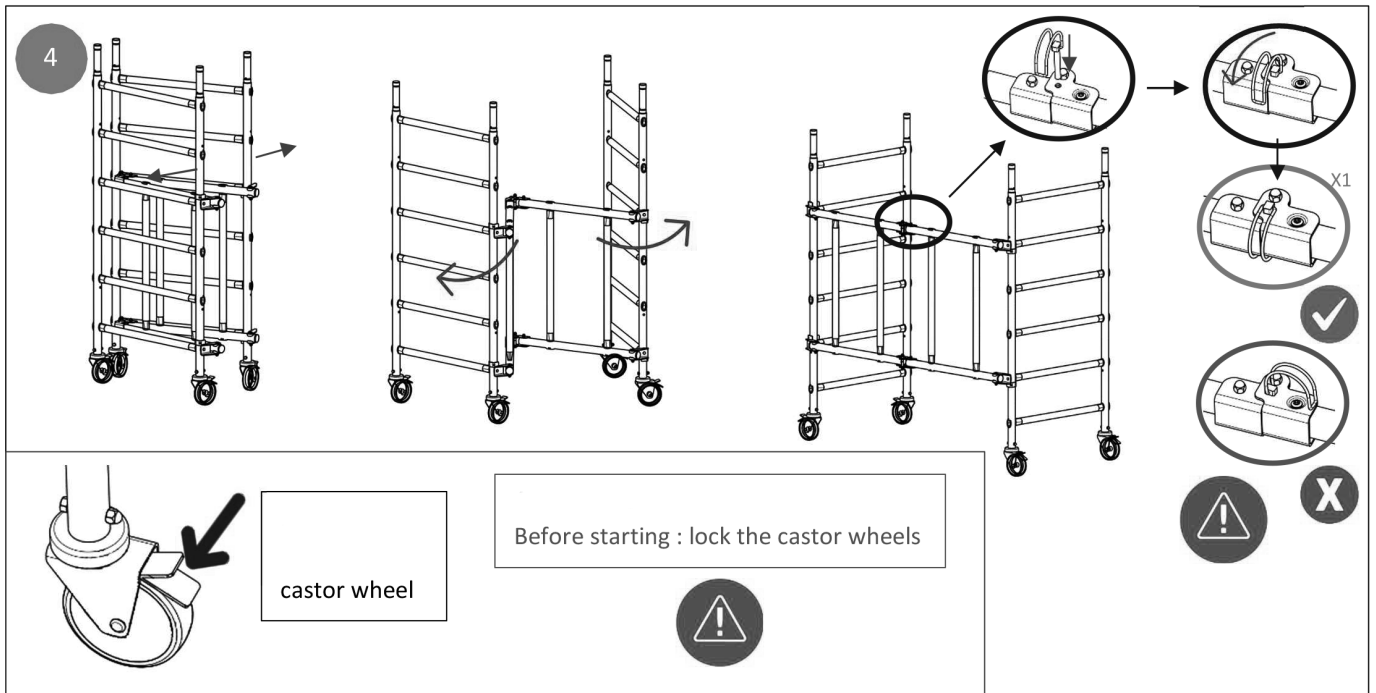

Diagonal

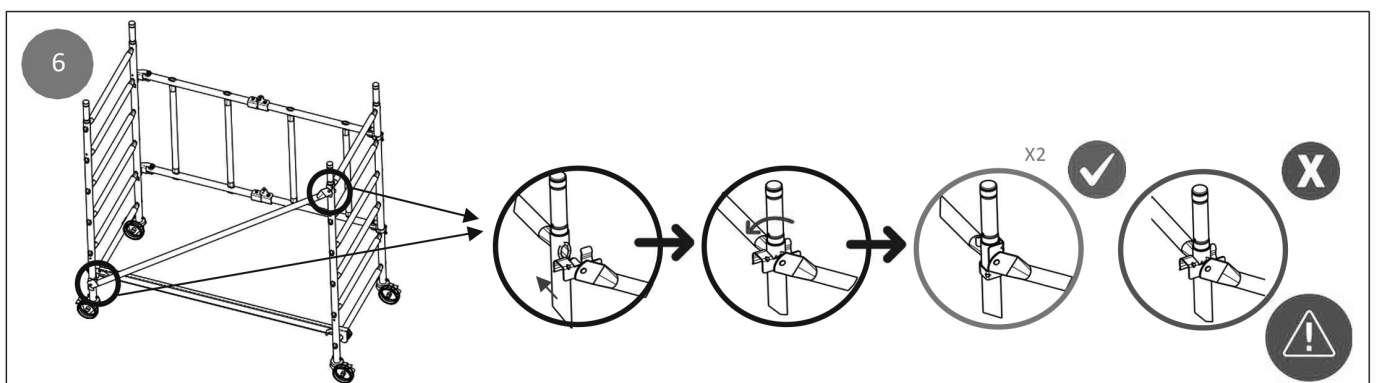

Platform

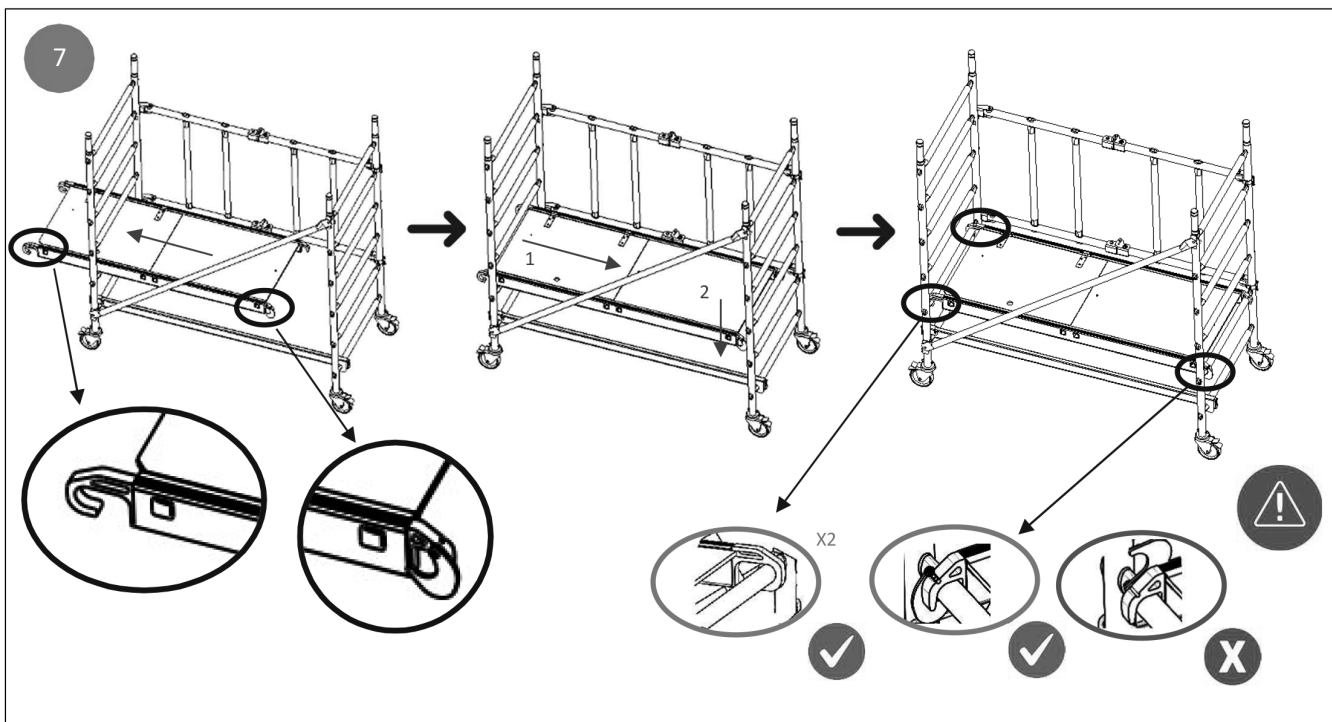

Stabilisers

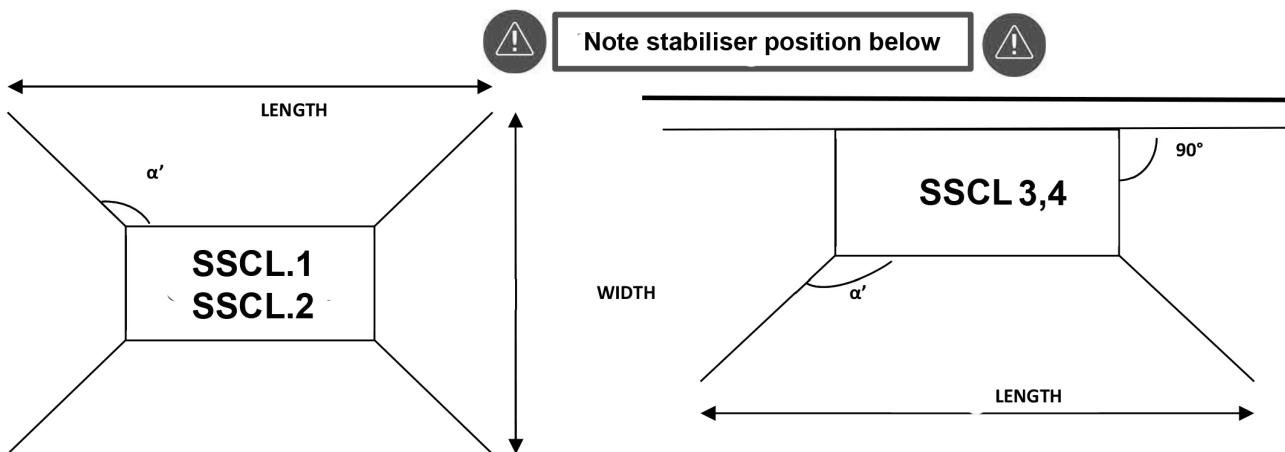
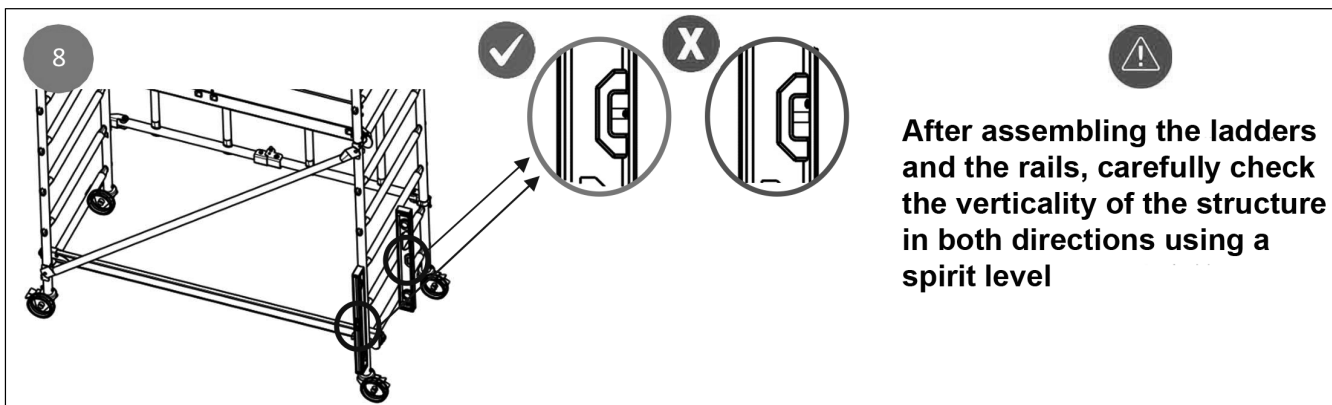

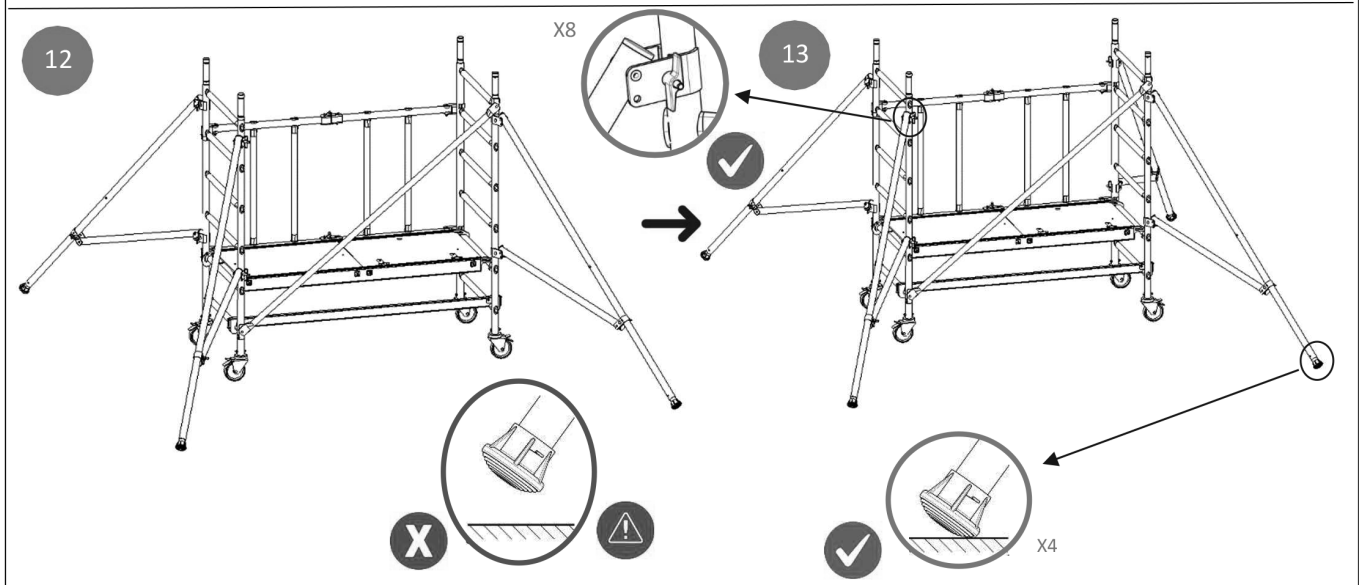
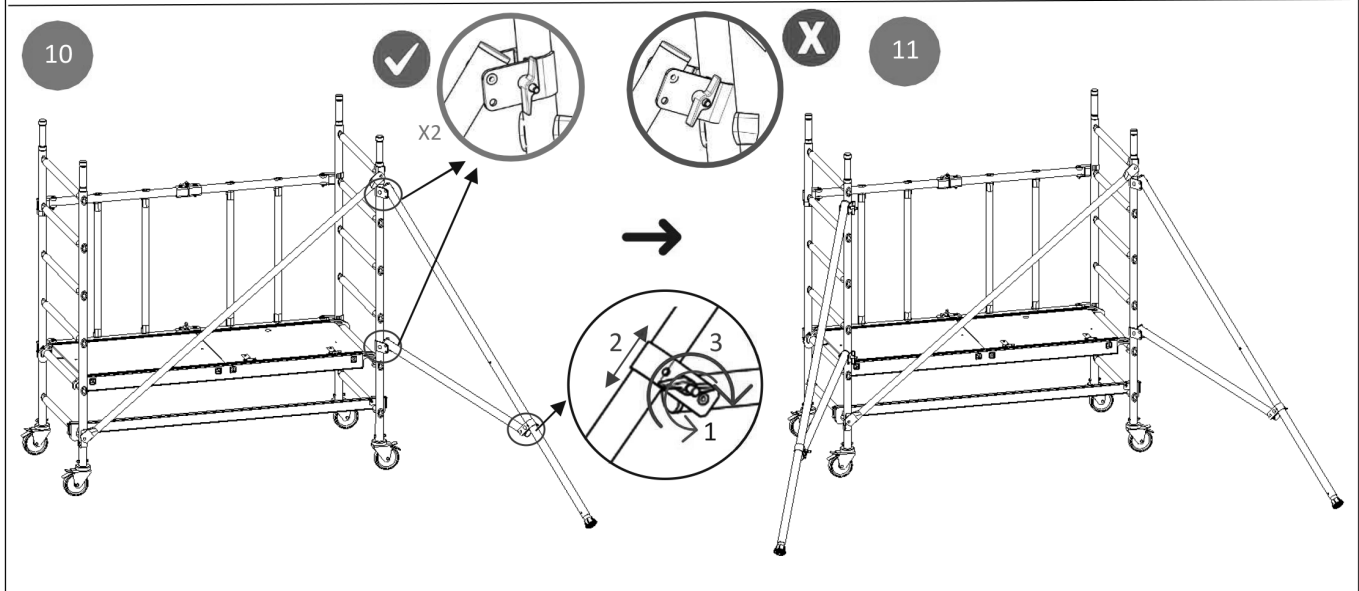
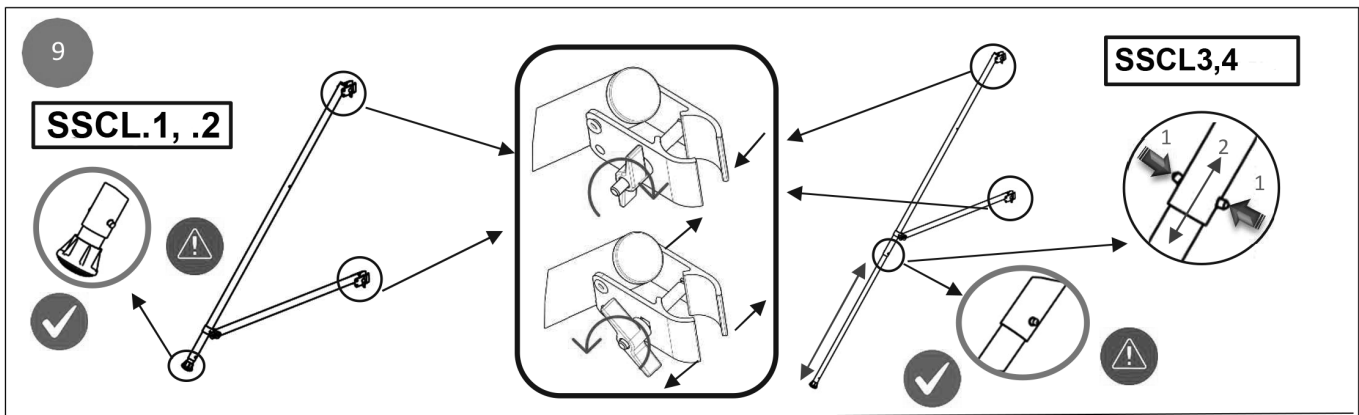

Before starting, check that the stabilisers do not move by ensuring that:

- the stabilisers are in contact with the ground
- distances and angles are in line with assembly procedures

Rails SSCL.1

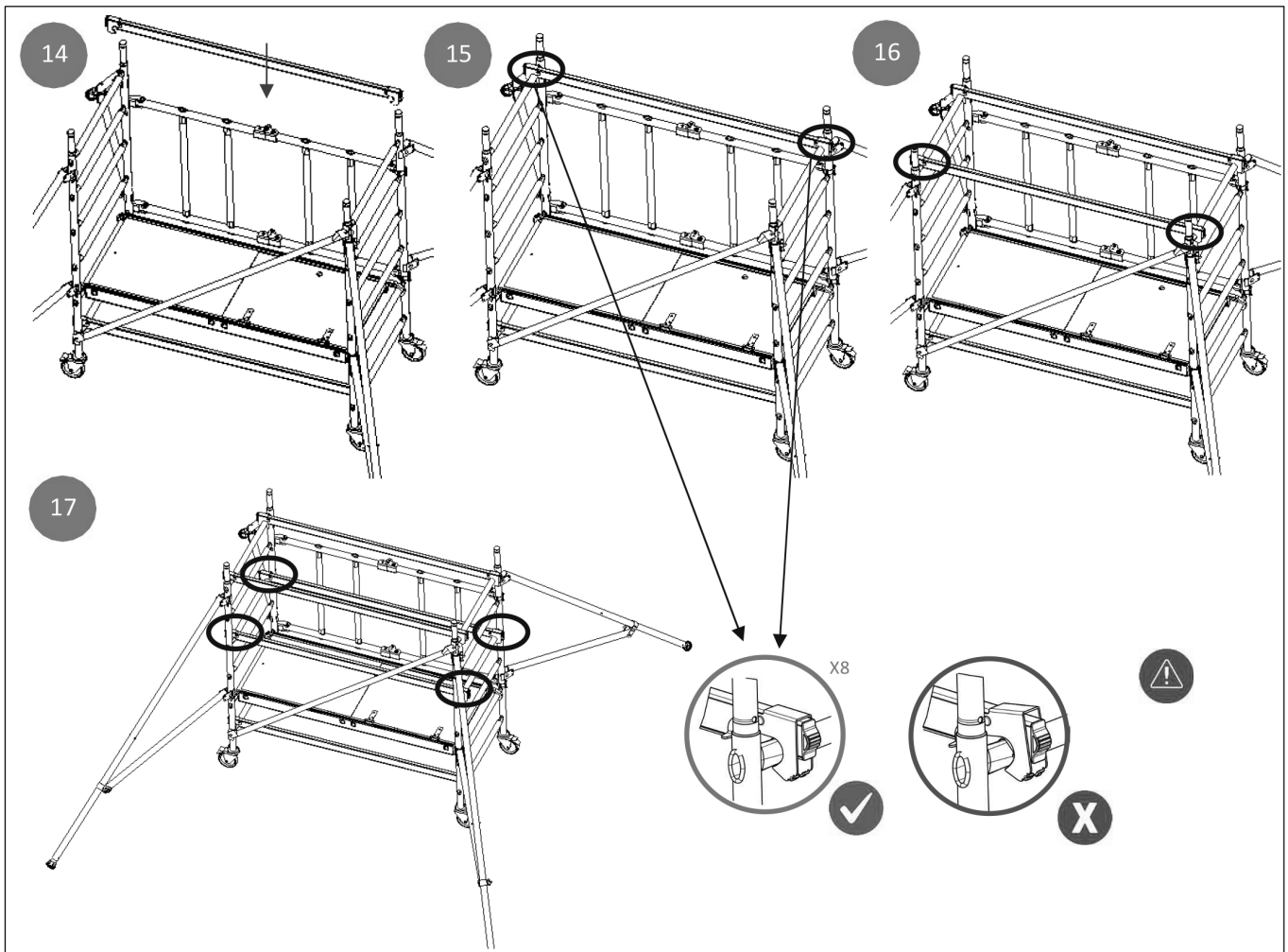

Toeboards

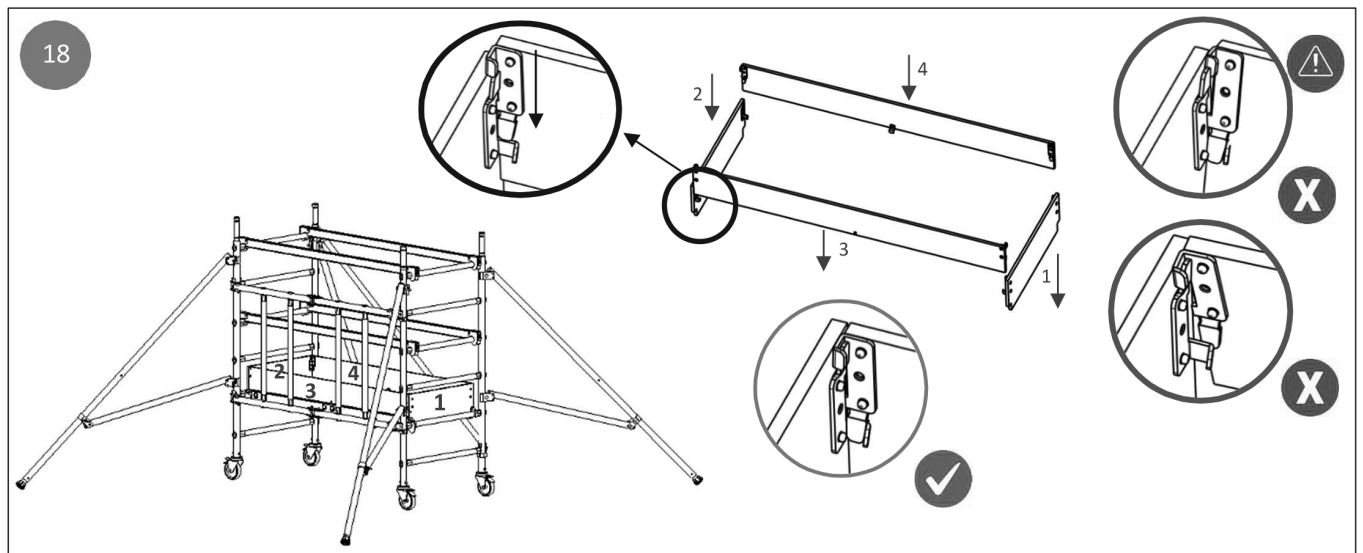

The product is ready for use at 0.6m

Extension 1m SSCL.2

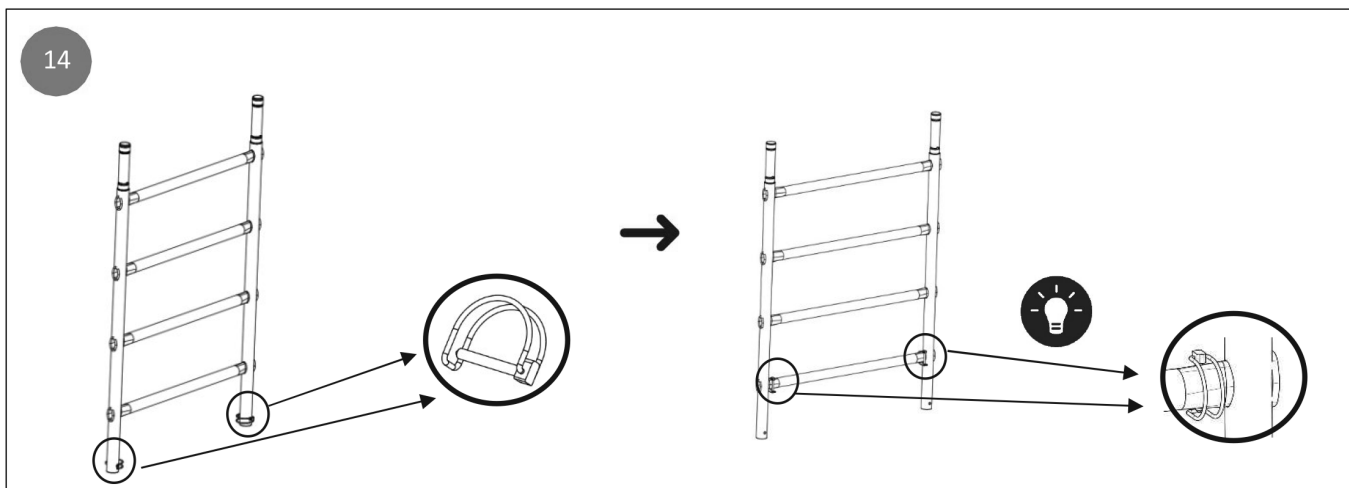

Start from assembled base see stage 8

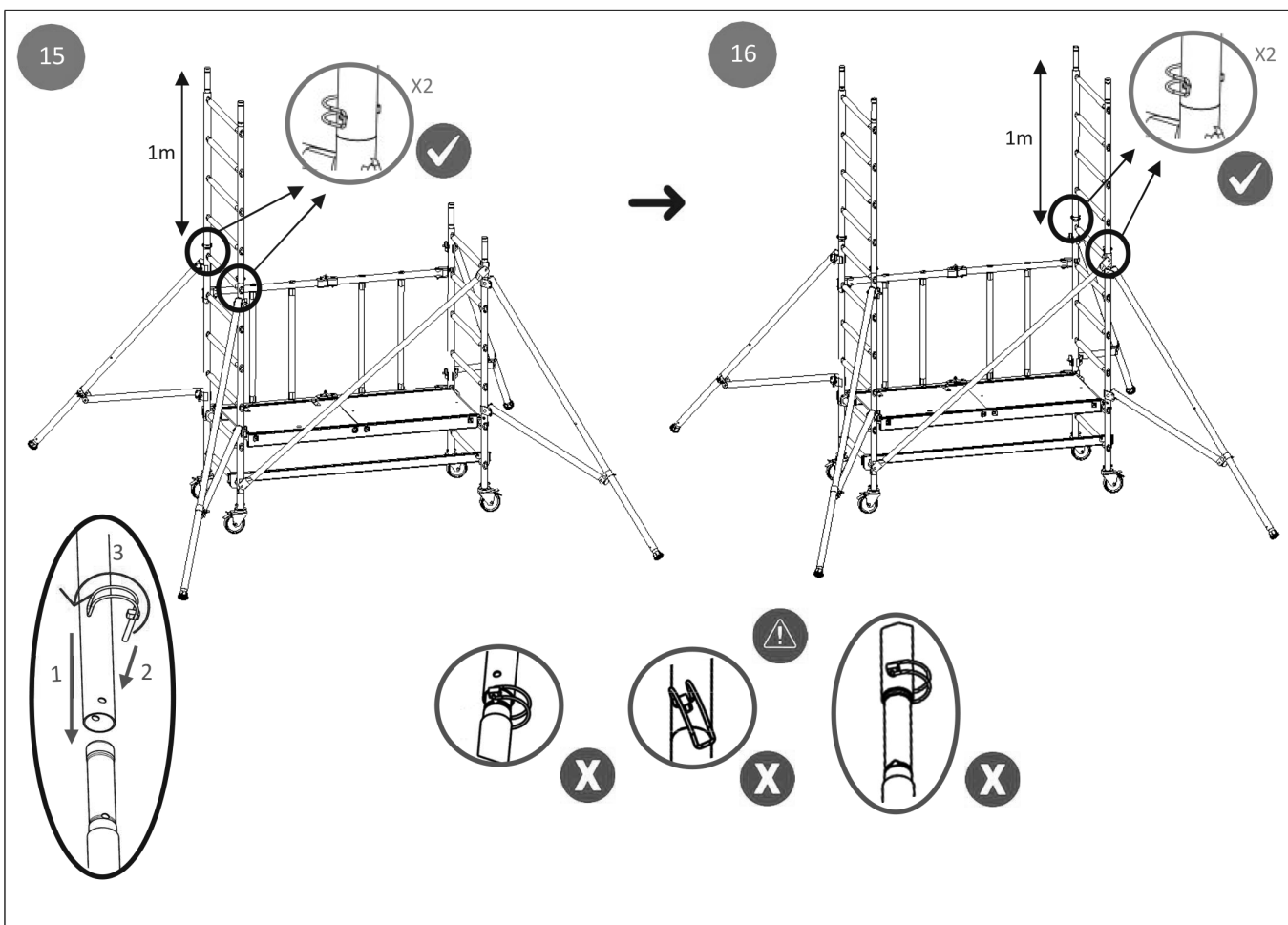

Platform Position the platform at the required height

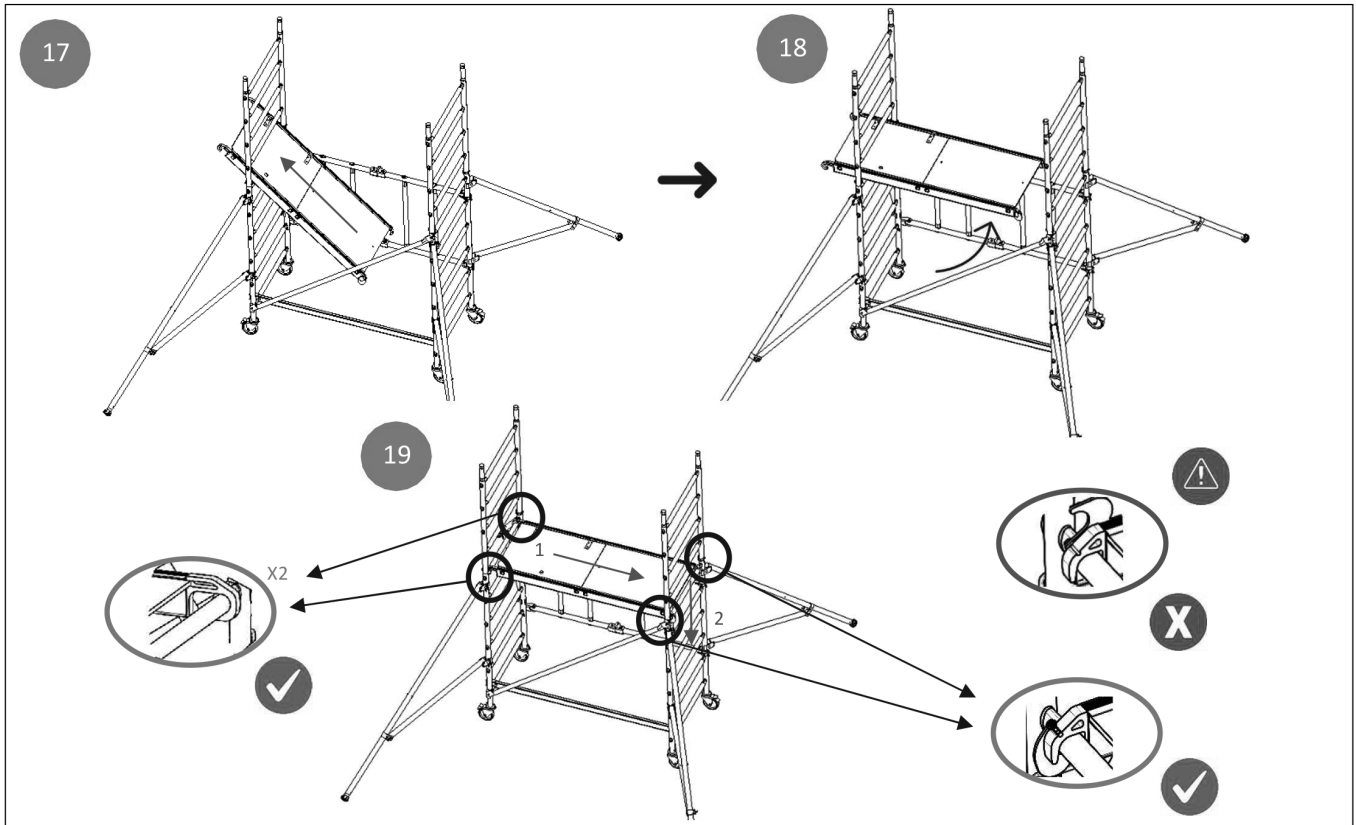

Rails

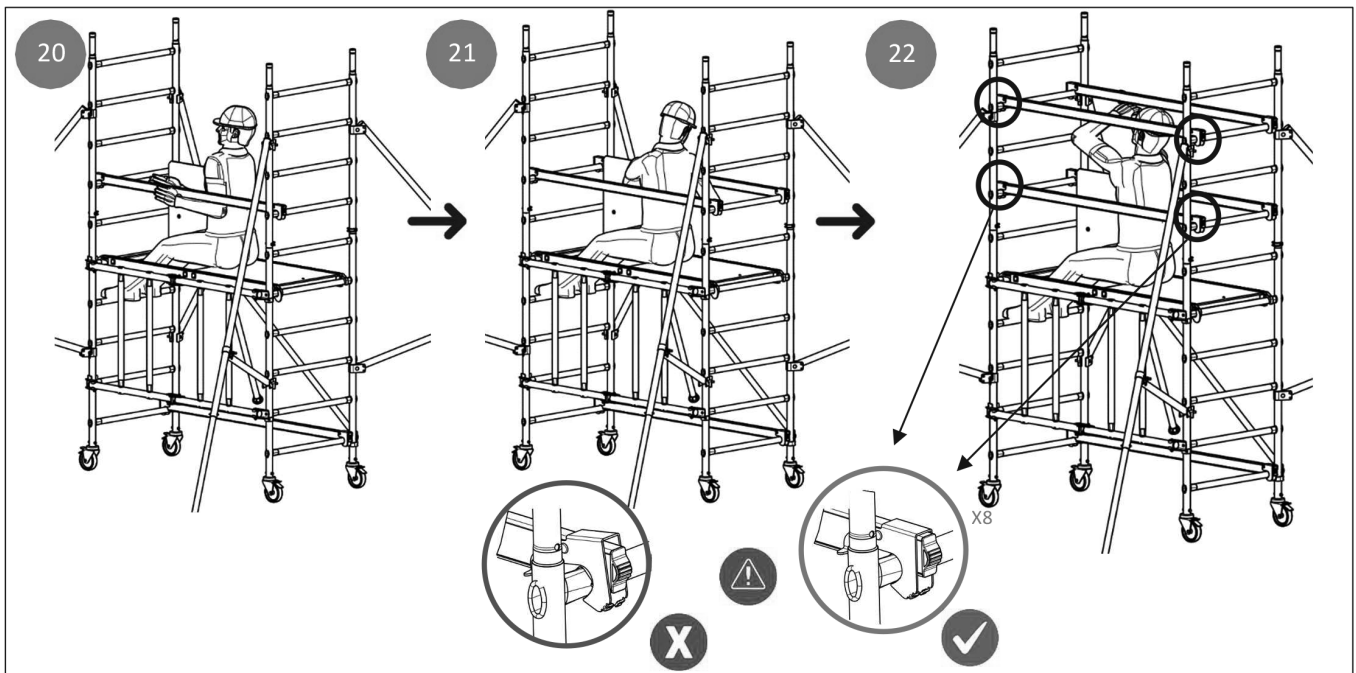

Toeboards

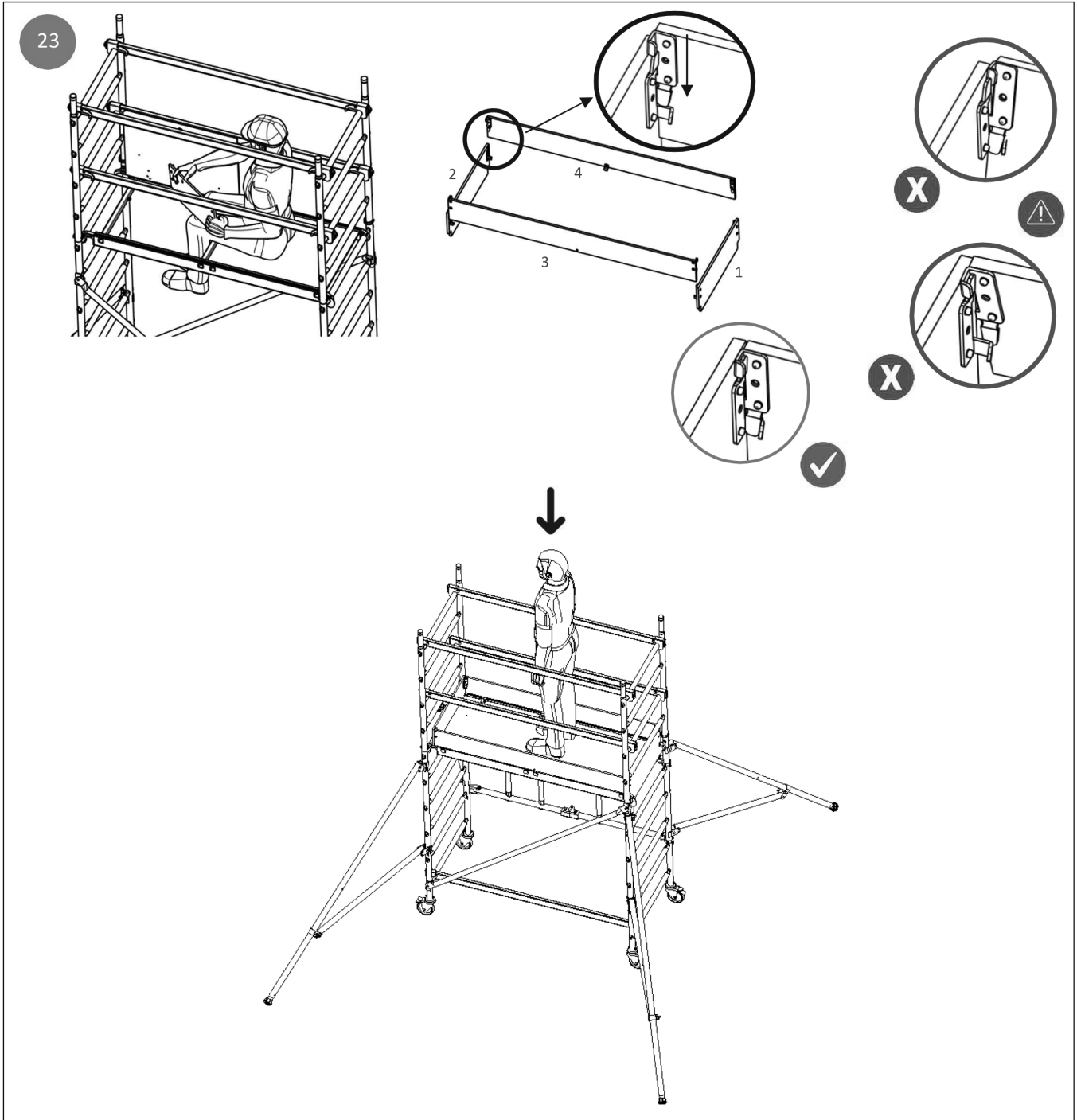

SSCL3 Stabilisers

Start from the assembled base step 23 and completely install the stabilisers refer to step 8

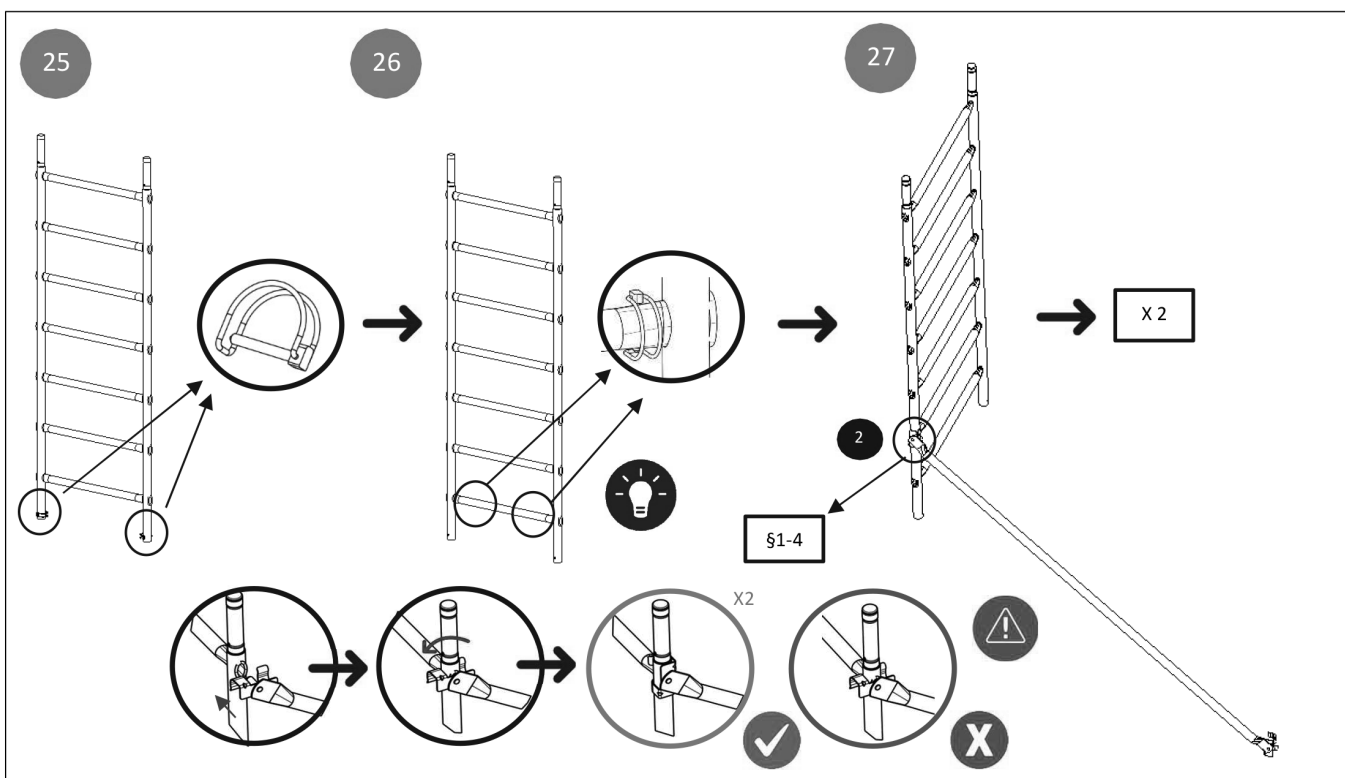
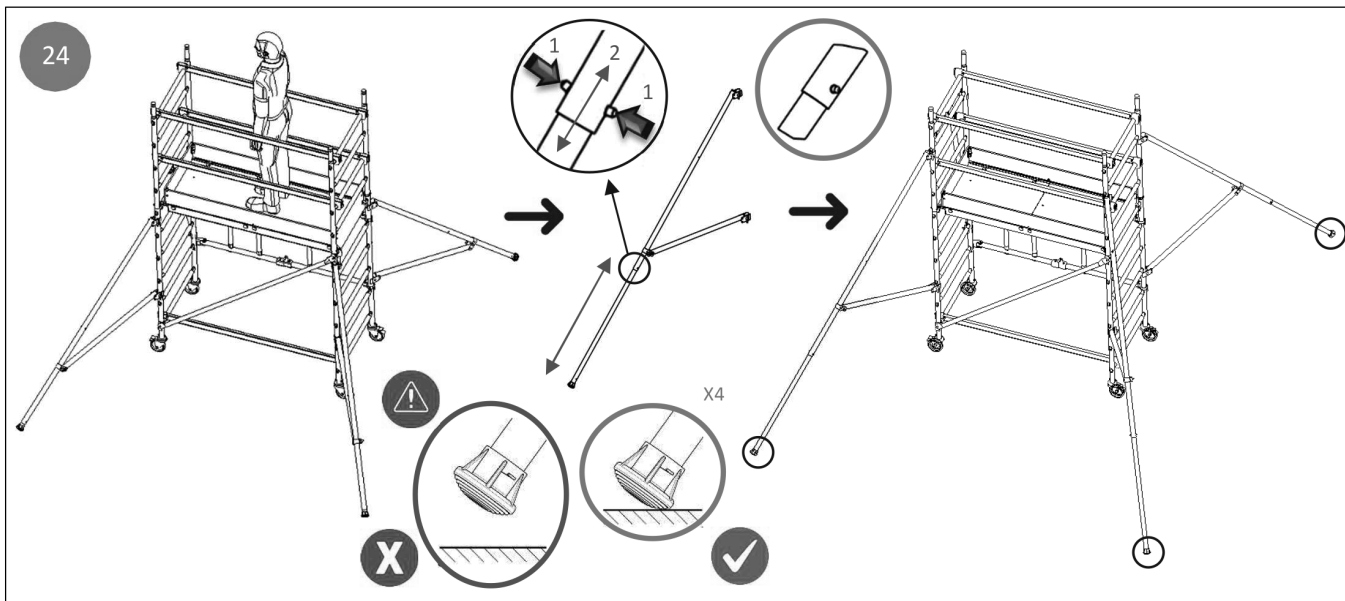

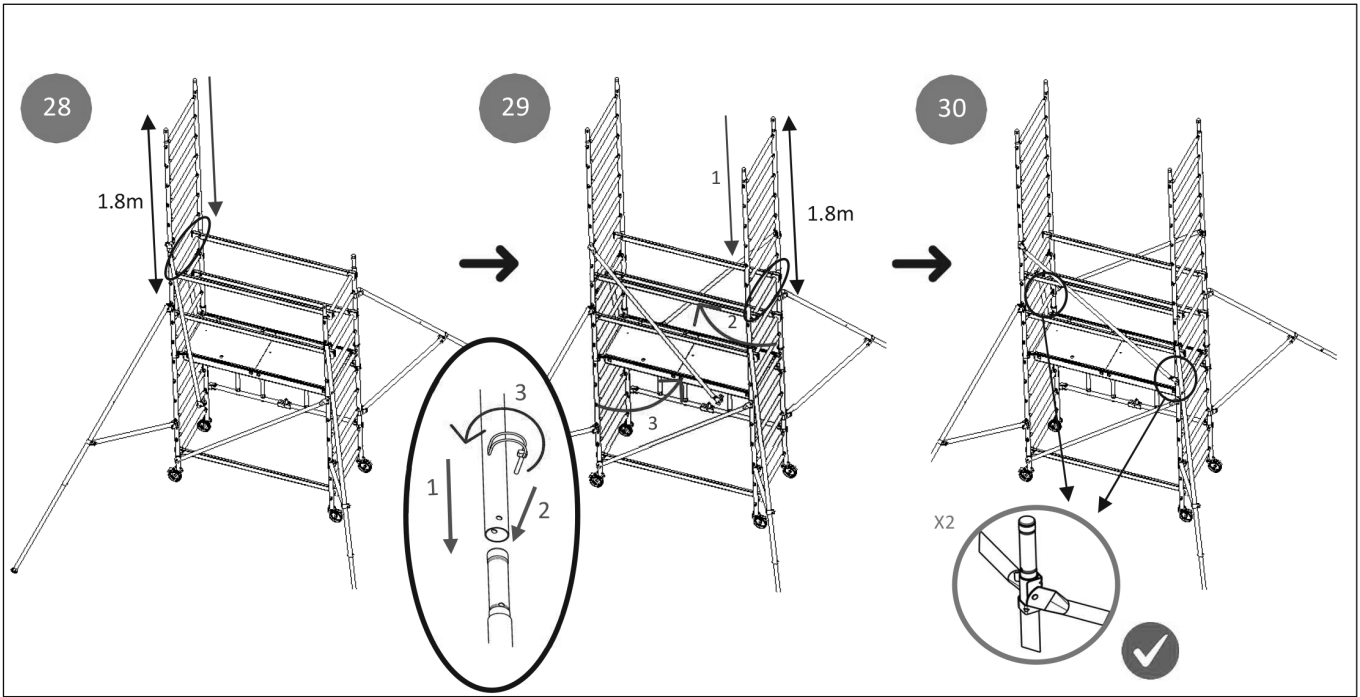

Fitting platform and rails

Install the 2nd platform on the 13th rung refer steps 17 to 18, and place rails as shown in steps 20 to 23

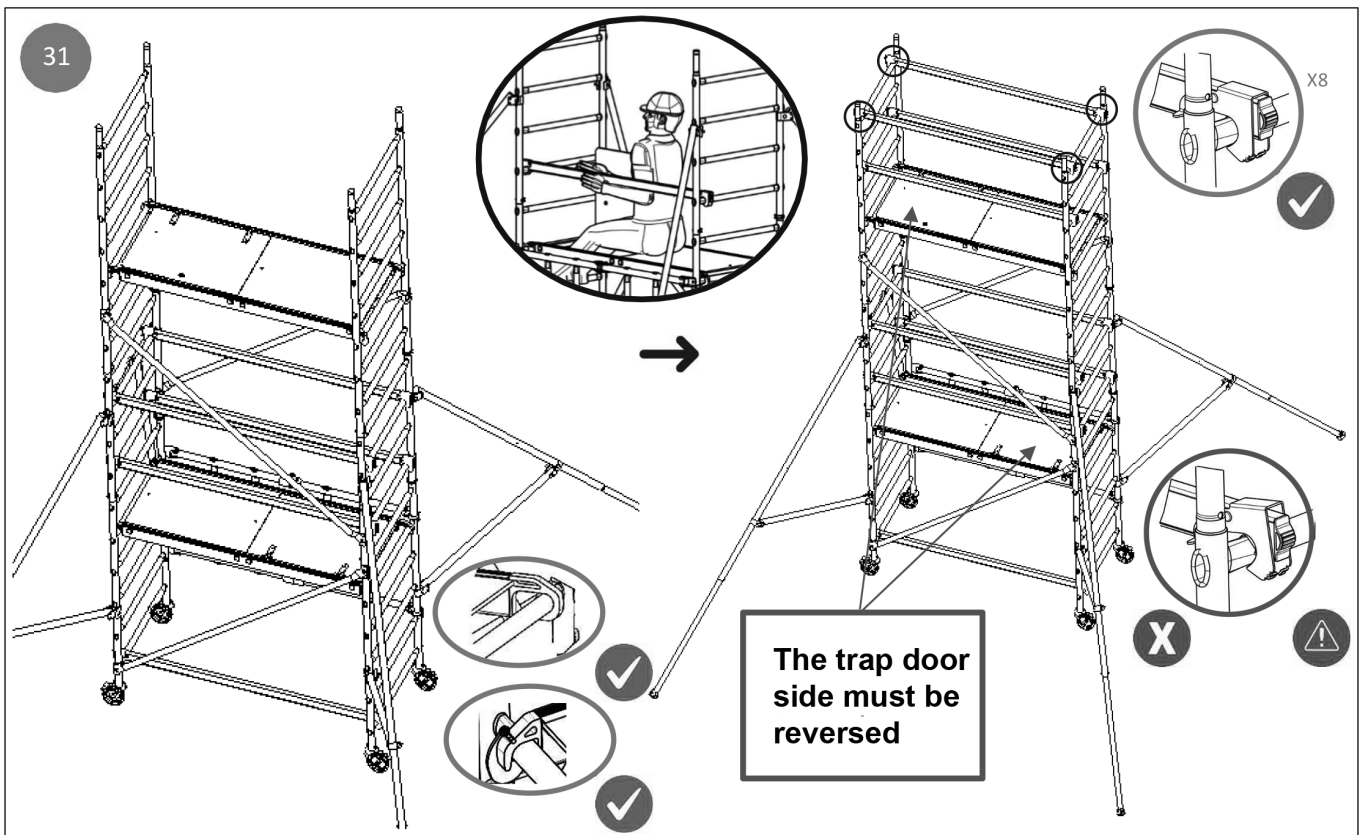

Toeboards

Position the toeboards as in step 23

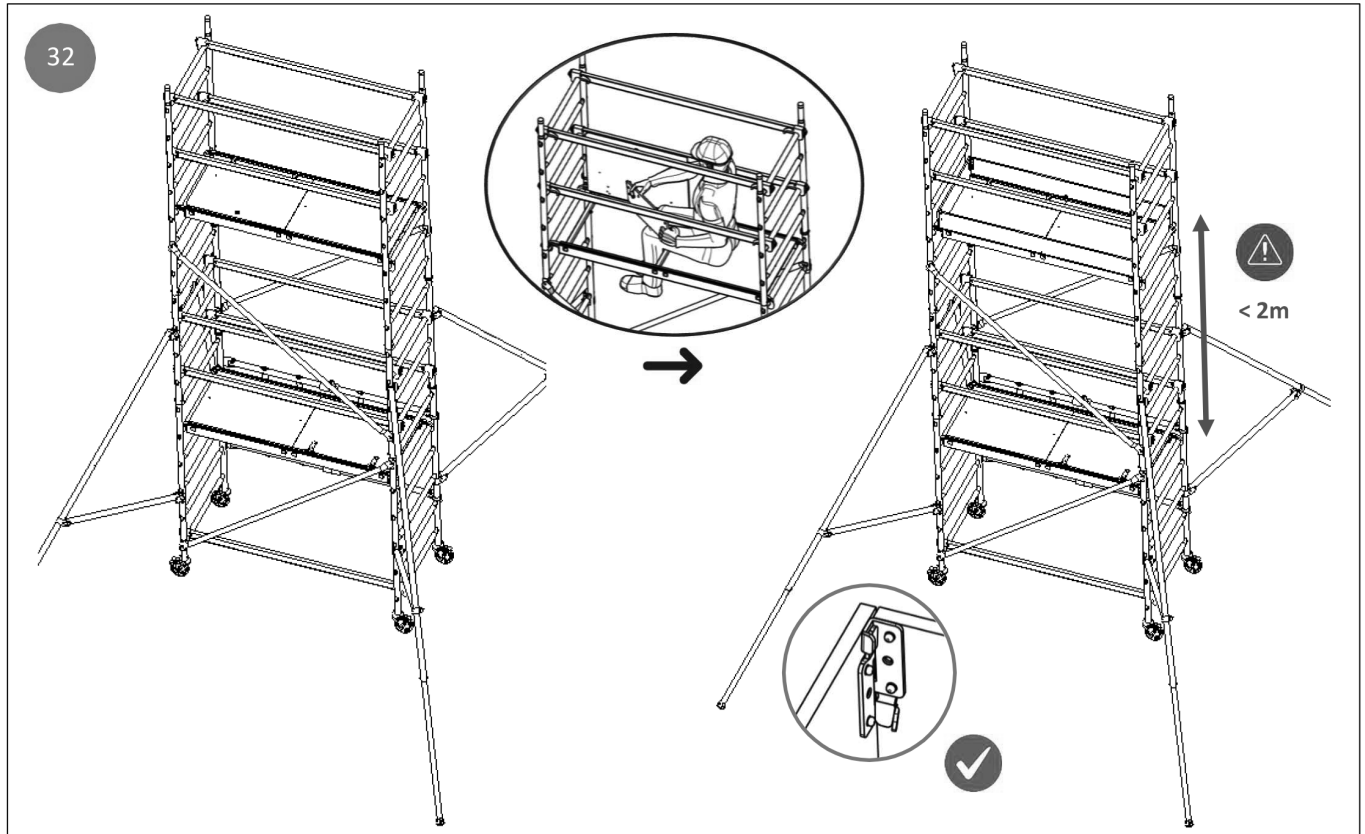

The product is ready to use at a height of 3.3m

SSCL4

Start from the assembled base step 25 then add the 2nd platform to the 12th rung refer to step 17

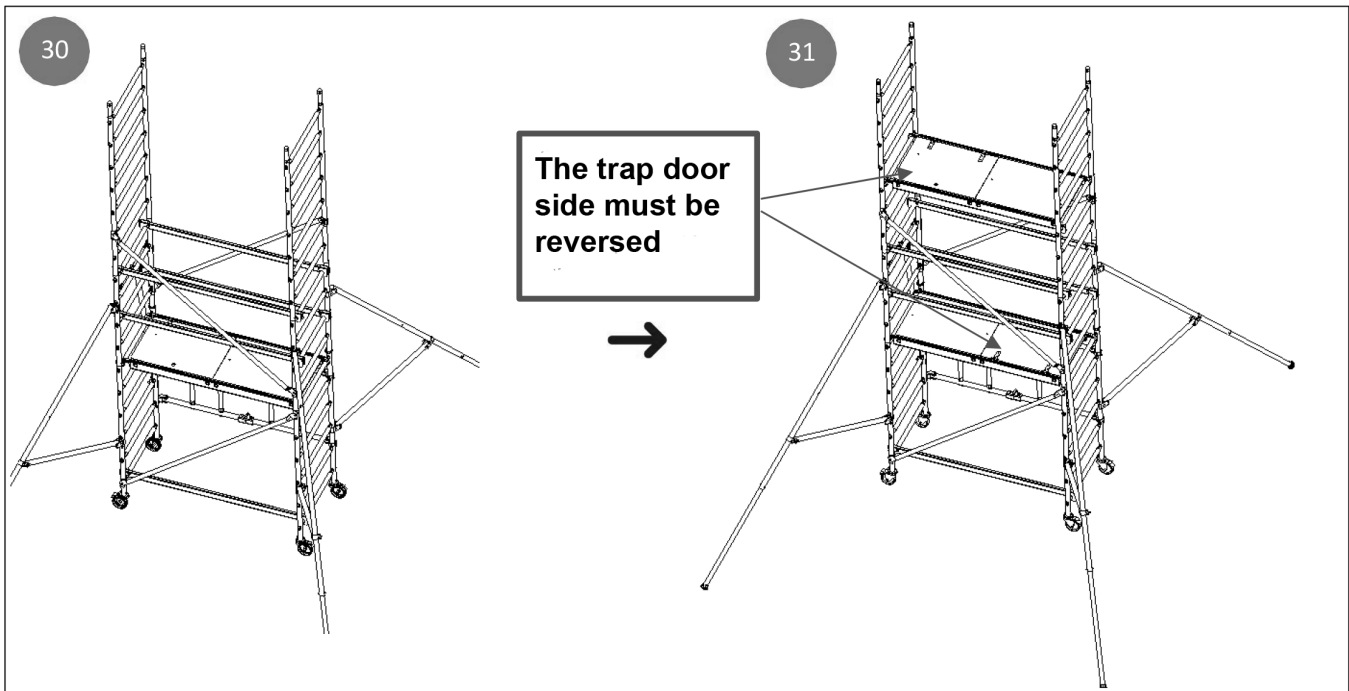

Position the rails as shown in step 20

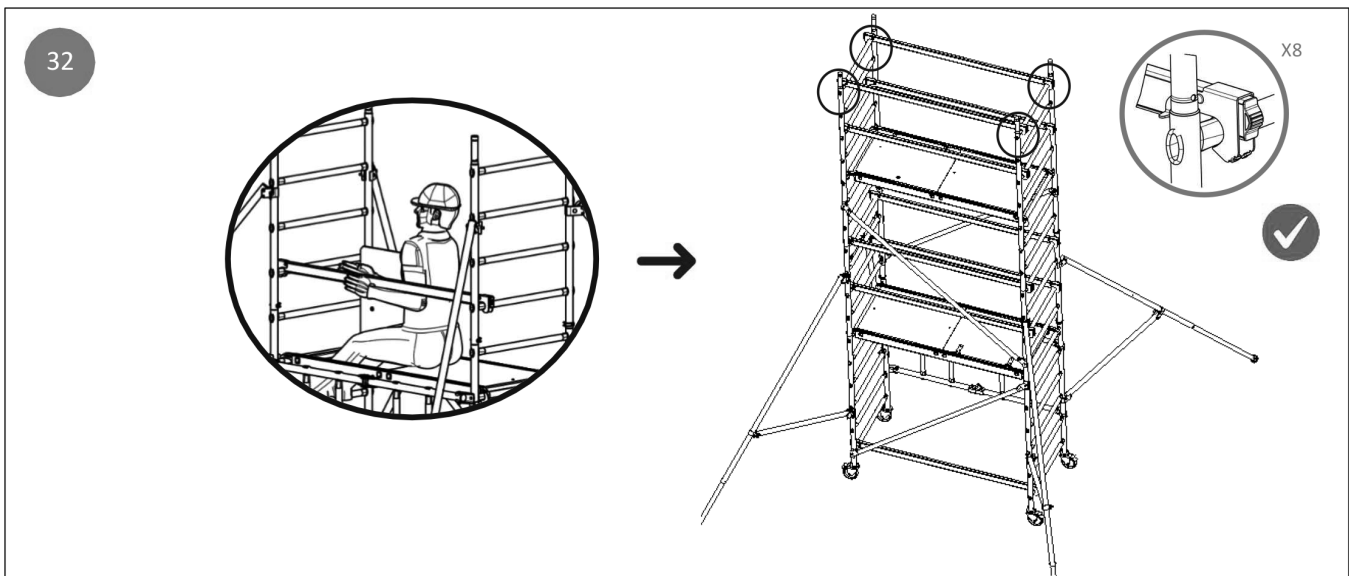

Adding 1.8m

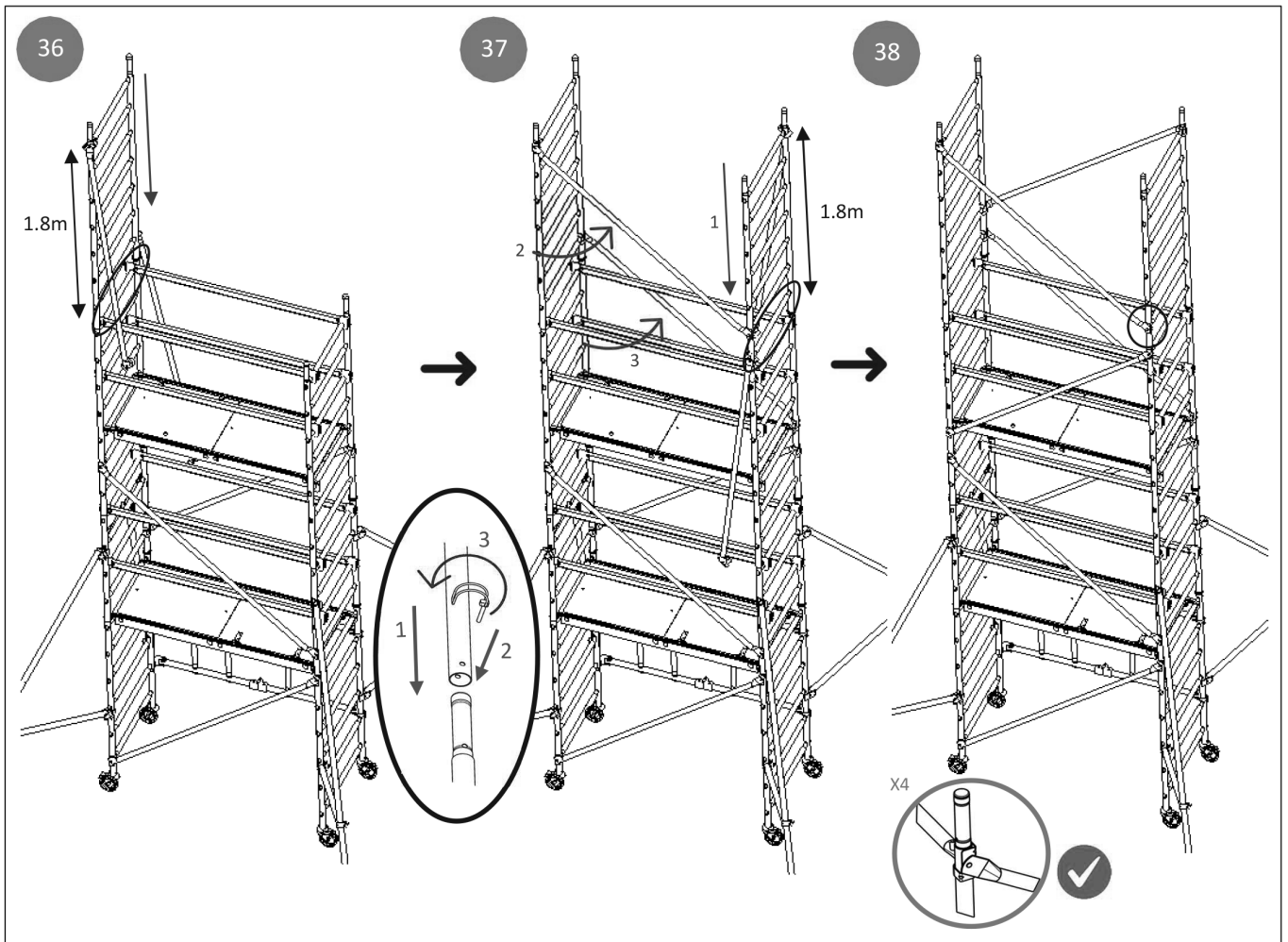
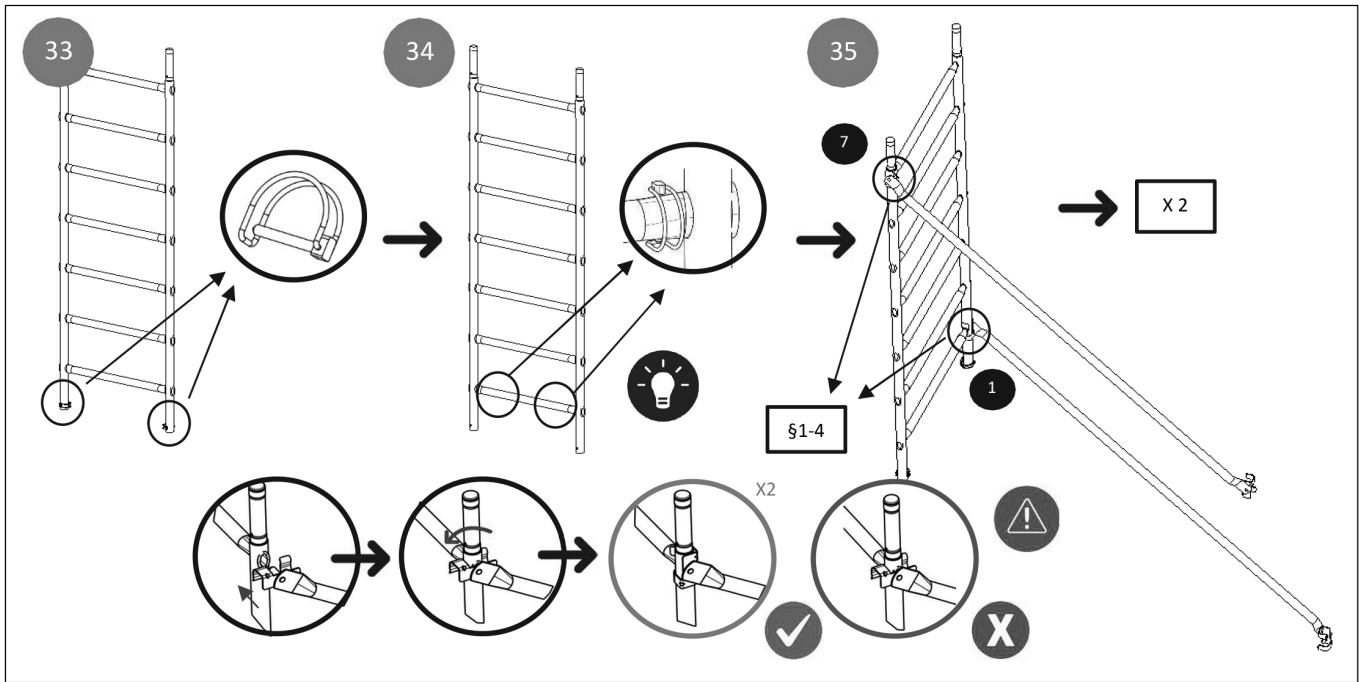

Move the 1st platform to the 20th rung, refer to step 17, along with the rails, step 20, put in the toeboards step 23

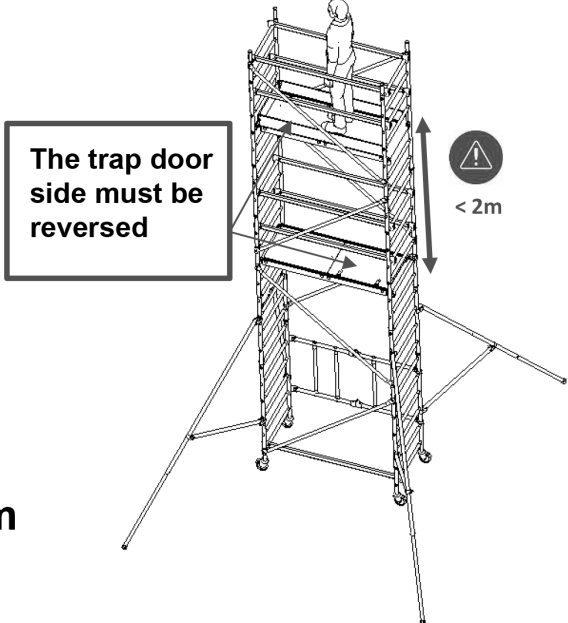
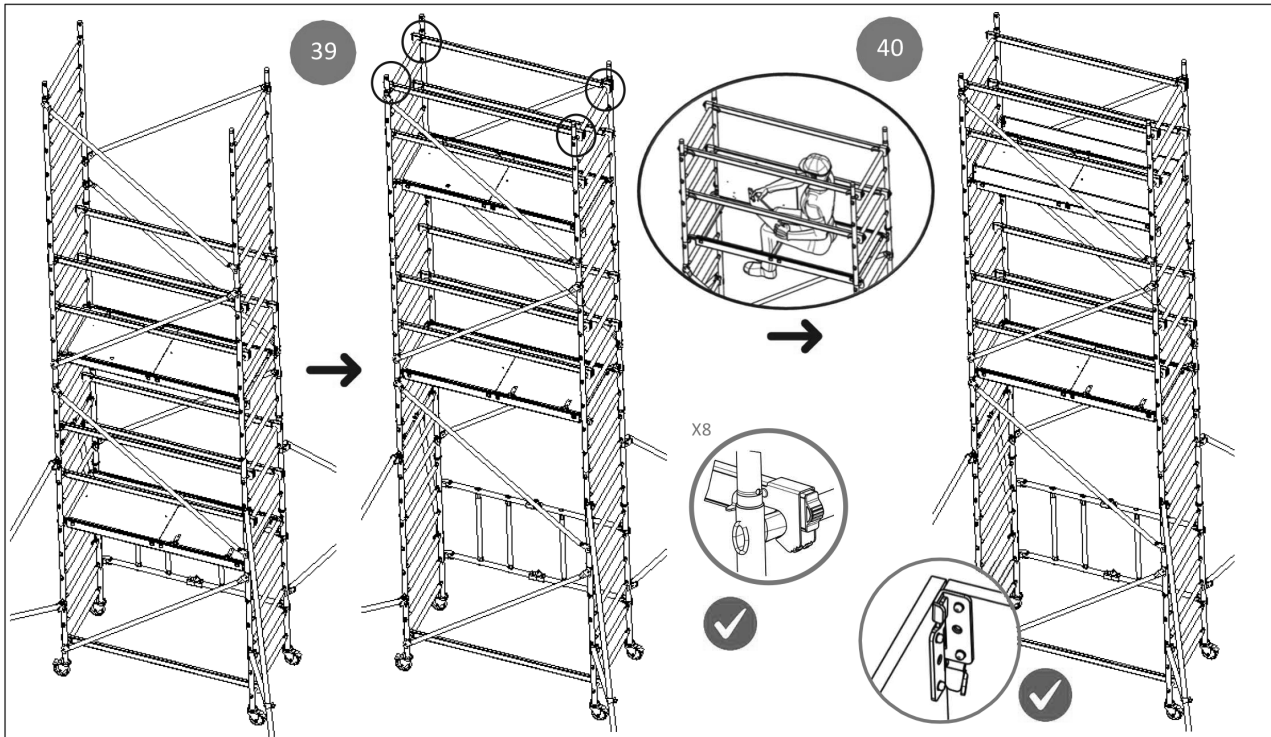

Ready to use at a height of 5.1m

Stepped surface

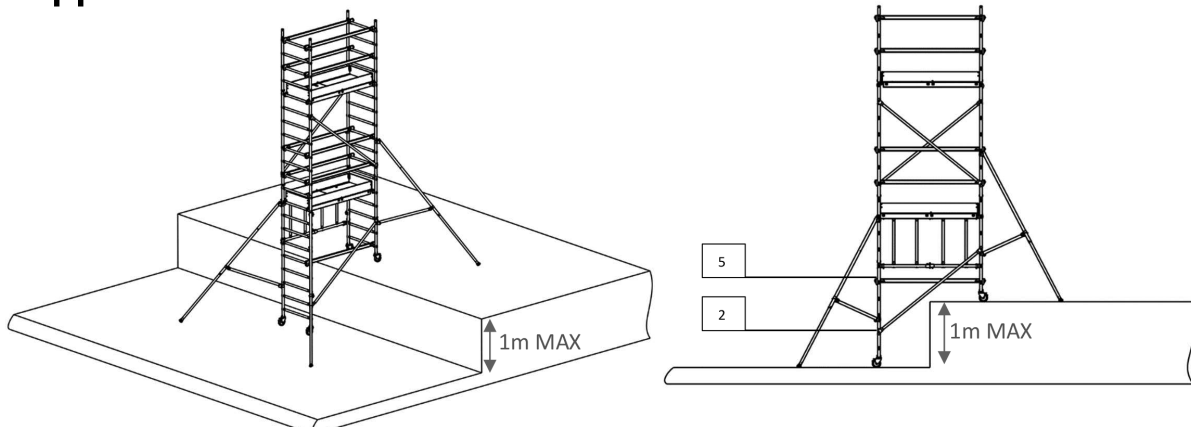

- 6.1. Correct assembly should be verified by the appropriately trained person who has been appointed by the company's on-site safety delegate.
The checks will cover:
- ✓ Whether the structure is in good condition.
 - ✓ The completely assembled structure.
 - ✓ Verifying whether the mobile tower is correctly assembled and complete.
 - ✓ Verifying whether the mobile tower is vertical or if it needs adjusting.
 - ✓ Verifying that there is no environmental change which may affect the safe use of the mobile tower.
 - ✓ Verifying that the stabilizers and the stabilizer legs comply with the instruction manual.
 - ✓ The brakes (locked wheels)
 - ✓ The cushioning (to compensate for localised defects in flatness)
- 6.2. ALWAYS follow the instruction manual supplied with the product.
- 6.3. These instructions should be available at the site where the mobile access and working tower is being used.
- 6.4. Check that the product, and particularly the safety devices, are in good general condition before each use (part condition and geometry). Where parts need to be replaced, only use genuine components.

7. MAINTENANCE

- 7.1. After use at each site, ensure that the mobile tower is cleaned with a clean cloth.
- 7.2. Inspect parts before each assembly, particularly:
- Castor wheels tyres and brakes.
 - Safety devices.
 - Working platform hooks and fasteners.
 - The plywood on the working platforms.
 - The stabiliser mounting brackets.
- All parts with the following defects:
- Permanent deformation.
 - Perforations.
 - Score marks (as a result of grinding, for example)
 - Severe oxidation
- The part should be discarded!
- 7.3. If in doubt, change the part. When the part is being changed, it must be replaced with a genuine part.
- 7.4. Keep parts clean, and safety devices in good working order.
- 7.5. Replace or clean all the panels or stickers with operating and safety instructions.
- 7.6. **CHECKS:**
- 7.6.1. This product should be checked periodically and the results of these checks should be recorded.
A check prior to use at each installation site:
- when the mobile tower is used for the first time,
 - when the mobile access and working tower is dismantled and then re-assembled.
 - following changes in usage conditions, or atmospheric or environmental conditions which may affect the safe use of the mobile access and working tower,
 - when the tower has not been used for at least a month.
- This check should include a suitability assessment, an assembly and installation assessment, as well as an assessment of its condition. This check will be recorded in the establishment's safety records for traceability.
- 7.6.2. **A DAILY CHECK**
This is a condition assessment.
This check will be recorded on a sheet attached to the access hatch for traceability.
- 7.6.3. **A QUARTERLY CHECK**
For the mobile access and working tower, the scope of this check is comparable to the daily check. It will be carried out at least **once every 3 months, and will be recorded in the establishment's safety records for traceability.**

8. DISMANTLING

- 8.1. **BEFORE DISMANTLING:**
- Ensure that the mobile access and working tower is stable.
 - All parts, tools and other necessary equipment to dismantle the mobile tower should be available on site.
 - The brake castor wheels are locked.
 - The stabilisers are correctly positioned etc.
 - Have ropes available to handle items if required.
- 8.2. **BEFORE HANDLING:**
- Put the split pins back on to the components.
 - Put damaged parts to one side to be replaced.
- 8.3. **DURING DISMANTLING:**
- 8.3.1. Use the procedure for assembling the tower in strict reverse order. Make sure the stabilizers are not dismantled first.
- 8.3.2. Dismantling requires two people, and PPE should be used.
- 8.3.3. Store the mobile tower in a dry, unobstructed, secure place where it is not at risk of getting damaged or being in the way.



ENVIRONMENT PROTECTION

Recycle unwanted materials instead of disposing of them as waste. All tools, accessories and packaging should be sorted, taken to a recycling centre and disposed of in a manner which is compatible with the environment. When the product becomes completely unserviceable and requires disposal, drain any fluids (if applicable) into approved containers and dispose of the product and fluids according to local regulations.



Note: It is our policy to continually improve products and as such we reserve the right to alter data, specifications and component parts without prior notice. Important: No Liability is accepted for incorrect use of this product.

Warranty: Guarantee is 12 months from purchase date, proof of which is required for any claim.

Sealey Group, Kempson Way, Suffolk Business Park, Bury St Edmunds, Suffolk. IP32 7AR



01284 757500



sales@sealey.co.uk



www.sealey.co.uk