

# SEALEY

## Ø216MM DOUBLE SLIDING COMPOUND MITRE SAW

MODEL NO: **SMS216.V2**

Thank you for purchasing a Sealey product. Manufactured to a high standard, this product will, if used according to these instructions, and properly maintained, give you years of trouble free performance.

**IMPORTANT:** PLEASE READ THESE INSTRUCTIONS CAREFULLY. NOTE THE SAFE OPERATIONAL REQUIREMENTS, WARNINGS & CAUTIONS. USE THE PRODUCT CORRECTLY AND WITH CARE FOR THE PURPOSE FOR WHICH IT IS INTENDED. FAILURE TO DO SO MAY CAUSE DAMAGE AND/OR PERSONAL INJURY AND WILL INVALIDATE THE WARRANTY. KEEP THESE INSTRUCTIONS SAFE FOR FUTURE USE.



Refer to instruction manual



Wear eye protection



Wear ear protection



Wear a mask



Wear protective gloves

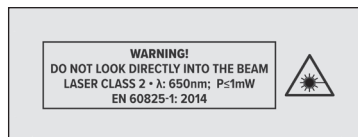

Warning!  
Laser beam

### 1. SAFETY

#### 1.1. ELECTRICAL SAFETY

- ❑ **WARNING!** It is the user's responsibility to check the following:  
Check all electrical equipment and appliances to ensure that they are safe before using. Inspect power supply leads, plugs and all electrical connections for wear and damage. Sealey recommend that an RCD (Residual Current Device) is used with all electrical products. You may obtain an RCD by contacting your local Sealey stockist.

if the multi-tool is used in the course of business duties, it must be maintained in a safe condition and routinely PAT (Portable Appliance Test) tested.

Electrical safety information. It is important that the following information is read and understood.

- 1.1.1. Ensure that the insulation on all cables and on the appliance is safe before connecting it to the power supply.
- 1.1.2. Regularly inspect power supply cables and plugs for wear or damage and check all connections to ensure that they are secure.
- 1.1.3. **IMPORTANT:** Ensure that the voltage rating on the appliance suits the power supply to be used and that the plug is fitted with the correct fuse - see fuse rating in these instructions.
  - × **DO NOT** pull or carry the appliance by the power cable.
  - × **DO NOT** pull the plug from the socket by the cable. Remove the plug from the socket by maintaining a firm grip on the plug.
  - × **DO NOT** use worn or damaged cables, plugs or connectors. Ensure that any faulty item is repaired or replaced immediately by a qualified electrician.

- 1.1.4. This product is fitted with a BS1363/A 13 Amp 3 pin plug.

If the cable or plug is damaged during use, switch off the electricity supply and remove from use.

Replace a damaged plug with a BS1363/A 13 Amp 3 pin plug. If in doubt contact a qualified electrician.

Class II products are wired with live (brown) and neutral (blue) only and are marked with the Class II symbol;



A) Connect the BROWN live wire to the live terminal 'L'.

B) Connect the BLUE neutral wire to the neutral terminal 'N'.

C) After wiring, check that there are no bare wires and ensure that all wires have been correctly connected.

Ensure that the cable outer sheath extends inside the cable restraint and that the restraint is tight.

**DO NOT** connect either wire to the earth terminal.

Sealey recommend that repairs are carried out by a qualified electrician.

If an extension reel is used it should be fully unwound before connection. A reel with an RCD fitted is preferred since any appliance plugged into it will be protected. The cable core section is important and

should be at least 1.5mm<sup>2</sup>, but to be absolutely sure that the capacity of the reel is suitable for this product and for others which may be used in the other output sockets, we recommend the use of 2.5mm<sup>2</sup> section cable. If extension reel is to be used outdoors, ensure it is marked for outdoor use.

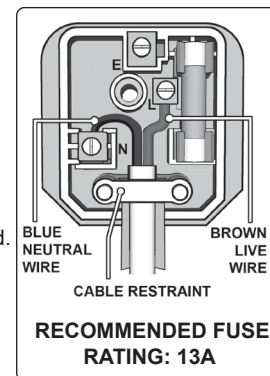

#### 1.2. GENERAL SAFETY

- ✓ Familiarise yourself with the applications, limitations and potential hazards of the saw.
- ❑ **WARNING!** Disconnect the saw from the mains power before changing accessories, servicing or performing any maintenance.
- ✓ The machine must only be serviced by a qualified person or service agent. Contact your Sealey stockist for information.
- ✓ Select a work area suitable for the saw and keep the area clean, tidy and free from unrelated materials. Ensure that there is adequate lighting.
- ✓ Wood dust can be harmful to health by inhalation and skin contact. Concentrations of small dust particles in the air can form an explosive mixture. Ensure that there is adequate ventilation and that the saw is attached to a dust-extraction unit.
- ✓ Maintain the saw in good condition, check moving parts alignment regularly. Keep saw blades clean and sharp.
- ✓ Replace or repair damaged parts. *Use recommended parts only. Unauthorised parts may be dangerous and will invalidate the warranty.*
- ❑ **WARNING!** Keep all guards and holding screws in place, tight and in good working order. Check regularly for damaged parts.
- ✓ A guard, or any other part, that is damaged should be repaired or replaced before the saw is next used. The safety guard is a mandatory fitting where the saw is used in premises covered by the Health & Safety at Work Act.
- ✓ Before commencing work, ensure the saw blade is set to cut in the correct direction, securely fastened, sharp and is compatible with the machine, spindle speed and the material to be cut. Never use a saw blade if damaged, bent or warped. Use only recommended saw blades.
- ✓ Remove adjusting keys and wrenches from the machine and the vicinity before switching on.
- ✓ Machine operators must have received sufficient training and instructions relating to the dangers associated with the machine, the precautions to be observed and the requirements of the Wood Working Machines Regulations.

Operators must be under the adequate supervision of a person who has a thorough knowledge and experience of the machine and the appropriate regulations.

- ✗ **DO NOT** operate the saw if any parts are damaged or missing as this may cause failure and/or personal injury.
- ✗ **DO NOT** operate the saw when you are tired or under the influence of alcohol, drugs or intoxicating medication.
- ✓ When not in use switch off the saw and unplug from the power supply.
- ☐ **WARNING!** Wear approved safety eye protection, ear defenders and, if dust is generated, respiratory protection.
- ✓ Remove ill fitting clothing. Remove ties, watches, rings and other loose jewellery and contain long hair.
- ✓ Keep hands and body clear of the blade when operating the saw.
- ✓ Maintain correct balance and footing. Ensure the floor is not slippery and wear non-slip shoes.
- ✓ Keep children and unauthorised persons away from the work area.
- ✓ Avoid unintentional starting and never leave the saw operating unattended.
- ✗ **DO NOT** use the saw for a task it is not designed to perform and ensure operators are trained to use the saw.
- ✗ **DO NOT** get the saw wet or use in damp or wet locations or areas where there is condensation.
- ✗ **DO NOT** use the saw where there are flammable liquids, solids or gases such as paint solvents and including waste cleaning rags etc.

### 1.3. SPECIFIC SAW SAFETY INSTRUCTIONS

- ✓ Mitre saws are intended to cut wood or wood-like products, they cannot be used with abrasive cut-off wheels for cutting ferrous material such as bars, rods, studs, etc. Abrasive dust causes moving parts such as the lower guard to jam. Sparks from abrasive cutting will burn the lower guard, the kerf insert and other plastic parts.
- ✓ Use clamps to support the workpiece whenever possible. If supporting the workpiece by hand, you must always keep your hand at least 100 mm from either side of the saw blade. Do not use this saw to cut pieces that are too small to be securely clamped or held by hand. If your hand is placed too close to the saw blade, there is an increased risk of injury from blade contact.
- ✓ The workpiece must be stationary and clamped or held against both the fence and the table. Do not feed the workpiece into the blade or cut "freehand" in any way. Unrestrained or moving workpieces could be thrown at high speeds, causing injury.
- ✓ Push the saw through the workpiece. Do not pull the saw through the workpiece. To make a cut, raise the saw head and pull it out over the workpiece without cutting, start the motor, press the saw head down and push the saw through the workpiece. Cutting on the pull stroke is likely to cause the saw blade to climb on top of the workpiece and violently throw the blade assembly towards the operator.
- ✓ Never cross your hand over the intended line of cutting either in front or behind the saw blade. Supporting the workpiece "cross handed" i.e. holding the workpiece to the right of the saw blade with your left hand or vice versa is very dangerous.
- ✗ **DO NOT** reach behind the fence with either hand closer than 100 mm from either side of the saw blade, to remove wood scraps, or for any other reason while the blade is spinning. The proximity of the spinning saw blade to your hand may not be obvious and you may be seriously injured.
- ✓ Inspect your workpiece before cutting. If the workpiece is bowed or warped, clamp it with the outside bowed face toward the fence. Always make certain that there is no gap between the workpiece, fence and table along the line of the cut. Bent or warped workpieces can twist or shift and may cause binding on the spinning saw blade while cutting. There should be no nails or foreign objects in the workpiece.
- ✗ **DO NOT** use the saw until the table is clear of all tools, wood scraps, etc., except for the workpiece. Small debris or loose pieces of wood or other objects that contact the revolving blade can be thrown with high speed.
- ✓ Cut only one workpiece at a time. Stacked multiple workpieces cannot be adequately clamped or braced and may bind on the blade or shift during cutting.
- ✓ Ensure the mitre saw is mounted or placed on a level, firm work surface before use. A level and firm work surface reduces the risk of the mitre saw becoming unstable.
- ✓ Plan your work. Every time you change the bevel or mitre angle setting, make sure the adjustable fence is set correctly to support the workpiece and will not interfere with the blade or the guarding system. Without turning the tool "ON" and with no workpiece on the table, move the saw blade through a complete simulated cut to assure there will be no interference or danger of cutting the fence.
- ✓ Provide adequate support such as table extensions, saw horses, etc. for a workpiece that is wider or longer than the table top. Workpieces longer or wider than the mitre saw table can tip if not securely supported. If the cut-off piece or workpiece tips, it can lift the lower guard or be thrown by the spinning blade.
- ✓ The cut-off piece must not be jammed or pressed by any means against the spinning saw blade. If confined, i.e. using length stops, the cut-off piece could get wedged against the blade and thrown violently.
- ✓ Always use a clamp or a fixture designed to properly support round material such as rods or tubing. Rods have a tendency to roll while being cut, causing the blade to "bite" and pull the work with your hand into the blade.
- ✓ Let the blade reach full speed before contacting the workpiece. This will reduce the risk of the workpiece being thrown.
- ✓ If the workpiece or blade becomes jammed, turn the mitre saw off. Wait for all moving parts to stop and disconnect the plug from the power source and/or remove the battery pack. Then work to free the jammed material. Continued sawing with a jammed workpiece could cause loss of control or damage to the mitre saw.
- ✓ After finishing the cut, release the switch, hold the saw head down and wait for the blade to stop before removing the cut-off piece. Reaching with your hand near the coasting blade is dangerous.
- ✓ Hold the handle firmly when making an incomplete cut or when releasing the switch before the saw head is completely in the down position. The braking action of the saw may cause the saw head to be suddenly pulled downward, causing a risk of injury.
- ✓ Always use a fence or straight edge guide when ripping.
- ✓ Before making a cut make sure the depth, bevel and mitre adjustments are tight.
- ✓ Use correct blades. Do not use blades with incorrect size holes. Never use blade washers or bolts that are defective or incorrect. Refer to unit specification for maximum blade capacity etc.
- ✓ Inspect and remove all nails from timber before cutting.
- ✓ Never touch the blade or moving parts during use.
- ✓ Never start the saw when the blade is in contact with the workpiece.
- ✓ **LASER LIGHT. LASER RADIATION DO NOT** stare into beam. Only turn laser beam on when tool is on work piece.

## 2. INTRODUCTION

Powerful 1450W motor. Features integral aluminium workpiece supports which store inside the aluminium base to save space and prevent loss. Fitted with a 24-tooth TCT blade for fresh wood. Can be fitted with Model No. SMS216B multipurpose blade for use with mild steel, aluminium and wood with nails. Features double slides which can be locked at different lengths allowing greater control over the desired length of cut. Max cut of up to 310mm at 0° bevel. Unit is also fitted with a powerful LED work light and laser guide to help produce accurate cuts. Supplied with workpiece clamp, dust extraction bag and fitted with carry handle. Features locking increments at Mitre stops 0°, 15°, 22.5°, 31.6°, 35°, 45° Left & Right.

## 3. SPECIFICATION

Model no .....	SMS216.V2
Blade size .....	Ø216 x 2.8 x Ø30mm (24T)
Dust extraction port.....	Ø36mm/OD Ø40mm
Motor power .....	1450W
No-load speed.....	5000rpm
Positive mitre lock .....	0°, 15°, 22.5°, 31.6°, 35°, 45°
Supply.....	230V
Cross Cut (0° Bevel x 0° Table).....	62 x 310mm
Mitre Cut (0° Bevel x 45° Table): .....	62 x 215mm
Bevel Cut (45° Bevel x 45° Table): .....	34 x 215mm
Consumable Parts:...	SMS216B - Multipurpose Cut-Off Saw Blade Ø216 x 2.4mm/Ø30mm 32tpu

## 4. FEATURES

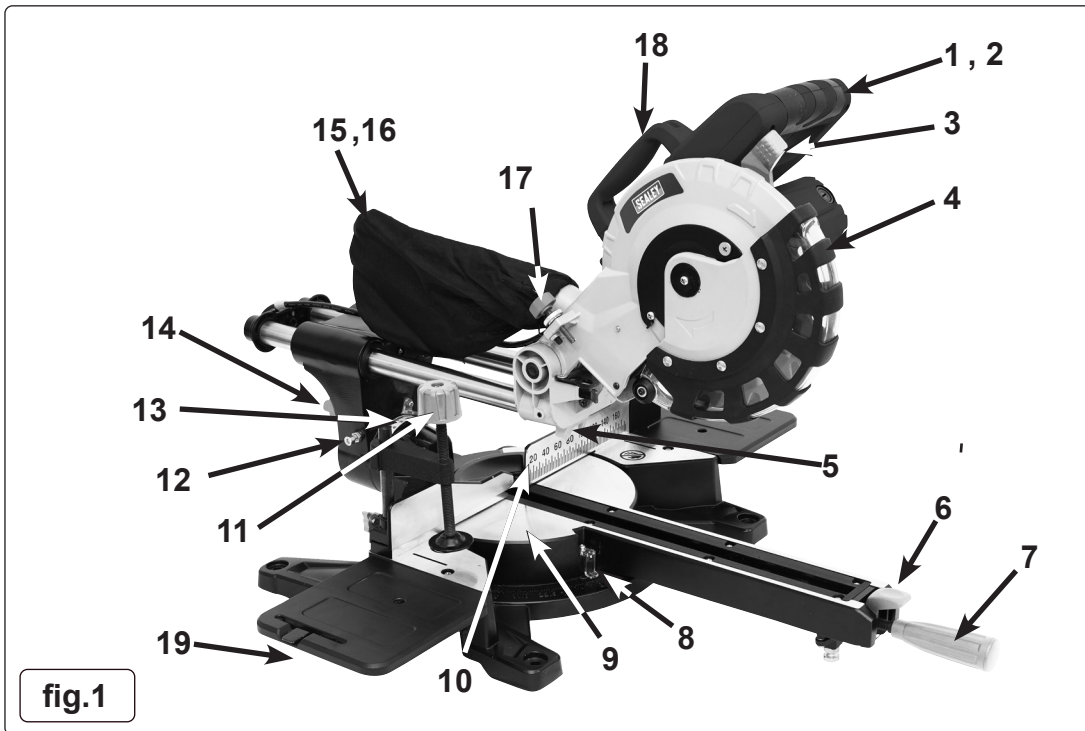

- 1 On/Off Trigger
- 2 Laser On/Off Button (far side)
- 3 Guard Release Lever
- 4 Blade guard
- 5 Laser (see fig.7)
- 6 Mitre lock
- 7 Mitre Locking Handle
- 8 Mitre Scale
- 9 Mitre Table
- 10 Fence
- 11 Clamp Assembly
- 12 Bevel Angle Stop Adjuster
- 13 Bevel Scale
- 14 Bevel Lock Lever
- 15 Dust Bag
- 16 Dust Extraction Port
- 17 Trenching Depth Adjustment Screw
- 18 Carrying Handle
- 19 Side Support

## 5. ASSEMBLY

- 5.1. Secure the saw to a flat, stable surface by inserting screws through the holes drilled in the machine's feet. The area should be well lit and have sufficient room to use the machine safely.
- 5.2. Unless using with a dust extractor, fit the dust bag (fig.1.15) onto the dust port (fig.1.16). If using dust extraction, use a suitable adaptor to couple the dust port and hose.

## 6. OPERATION

**NOTE:** Ensure all Safety Instructions in Section 1 are read and understood and carried out before use.

- ❑ **WARNING!** To prevent accidental starting that could cause possible serious personal injury, assemble all parts, make sure adjustments are complete, and make sure all fasteners are secure before connecting saw to power supply.
- ❑ **WARNING!** Saw should never be connected to power supply when you are assembling parts, making adjustments, installing or removing blades and when not in use.

### 6.1. BLADE LOCK (fig.1.3, fig.2)

- 6.1.1. To raise the blade; pull the guard release lever (fig.1.3, fig.2), disengage the Release Knob (fig.2) and lift the blade.
- 6.1.2. To lower, pull the guard release lever, which will allow the blade to be lowered (fig.2)
- 6.1.3. The blade assembly may be locked down by pushing the Release Knob (fig.2) in fully.
- 6.1.4. The saw may only be carried with the blade locked down.

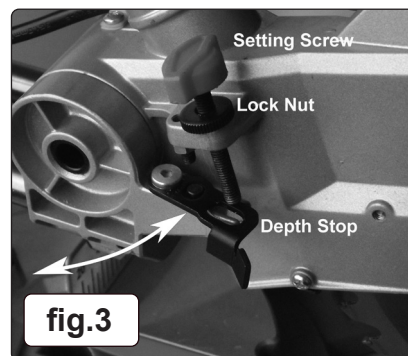
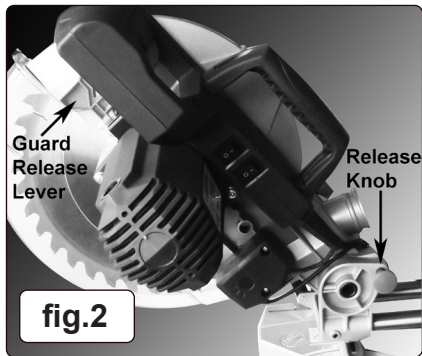

**6.2. DEPTH STOP (fig.3, fig.1.17)**

- 6.2.1. To activate, swing the depth stop over so the setting screw rests on it when the blade is lowered (fig.3, fig.1.17).
- 6.2.2. Adjust the setting screw engagement until the required cutting depth is achieved and tighten the lock nut to preserve that setting.
- 6.2.3. To make a full depth cut without losing the depth setting, push the depth stop across so the setting screw passes through it.

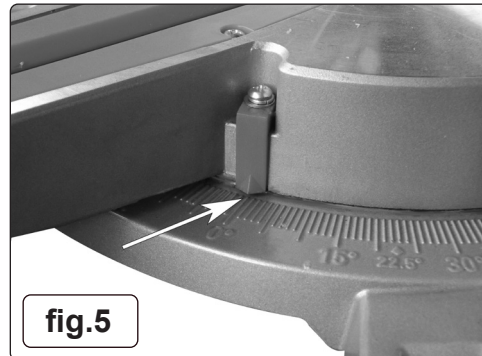
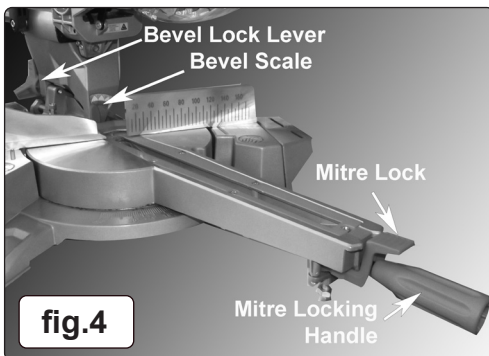

**6.3. MITRE ANGLE ADJUSTMENT (fig.4)**

- 6.3.1. The mitre angle can be set by loosening the mitre locking handle (fig.1.6, fig.4), depressing the Mitre Lock and adjusting the angle.
- 6.3.2. There are detents set at: 0°, 15°, 22.5°, 31.6°, 45° and the table can be set at these angles (fig.5), applying the locking handle (fig.1.7, fig.4) to secure it in place.
- 6.3.3. The mitre angle of the table can also be set at any other angle by reading the angle from the mitre scale and locking in position by rotating the locking handle until it is screwed in tightly and the table is fixed at the desired angle. To loosen the table, unscrew the locking handle until it turns easily.

**6.4. VERTICAL CUTTING ANGLE (BEVEL) (fig.5)**

- 6.4.1. To adjust the vertical cutting angle, loosen the bevel lock lever (fig.1.14, fig.4) and move the head to the required angle using the Bevel Scale (fig.1.13, fig.4) for guidance.
- 6.4.2. To check the vertical angle setting, lower and lock the blade as in section 6.1. Ensure that the pointer is set to zero.
- 6.4.3. Place a square (not supplied) against the blade to determine if the blade is perpendicular to the table.

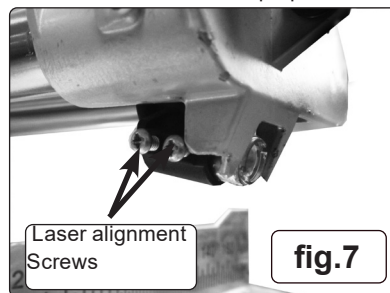
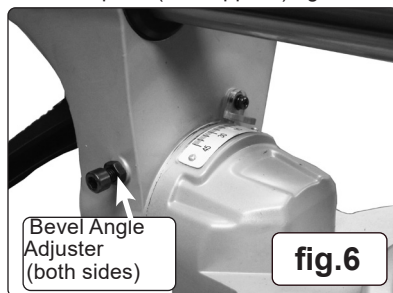

- 6.4.4. If not perpendicular, tilt the head over to reveal the bevel angle stop adjusters (fig.6, fig.1.12).
- 6.4.5. Loosen the adjuster lock nuts and, using a hex key, either screw the adjusters in or out in order to bring the blade square.
- 6.4.6. When the blade is true, tighten the lock nuts.
- 6.4.7. If necessary, loosen the screw securing the pointer and move the pointer to 0°. Tighten the securing screw after moving.

**6.5. SIDE SUPPORTS**

- 6.5.1. Side Supports (fig.1.19) are provided for both sides of the table. These must be locked in the required position to support long work.
- 6.5.2. Each support is provided with a retractable stop.

**6.6. CLAMP ASSEMBLY**

- 6.6.1. The Clamp Assembly (fig.1.11) may be fitted to either side of the table by fitting into the holder and secured using the thumb wheels.
- 6.6.2. Screw the clamp down onto the work whenever possible to secure before cutting.

**6.7. LASER GUIDE**

- 6.7.1. The laser cutting guide may be switched on with push button switch (fig.1.2). If the laser beam is showing off centre, turn laser on and use the two screws holding the laser unit in place to realign it with the centre line of the kerf plate (fig.7).

× **DO NOT** look into the laser light.

**6.8. FENCE GUIDE RAILS**

- 6.8.1. The guide rail travel is provided in two stages. If a limited travel is required, either stage may be locked by tightening the sliding lock (fig.1.11).
- 6.8.2. For cutting small section work, both rails may be locked so the saw head does not move to and fro.

## 6.9. CUTTING

- 6.9.1. To start the saw, unlock the blade, as in section 6.1. and depress the On/Off trigger in the handle (fig.1.1).
- 6.9.2. When using the sliding function, raise the head and pull forward. Lower the blade through the work and push back slowly to create the cut.
- 6.9.3. When the cut is complete, release the operating handle and wait for the blade to stop before removing the work.

## 7. MAINTENANCE

### 7.1. BLADE CHANGING

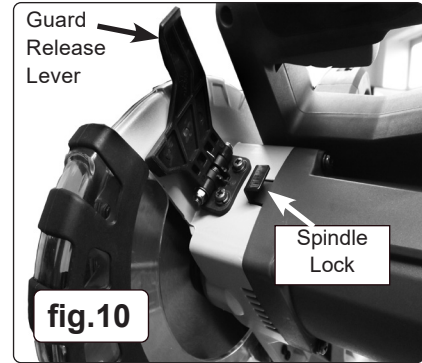
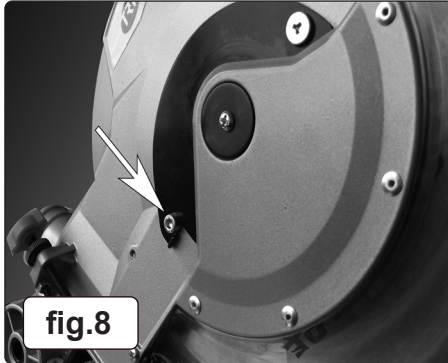

- 7.2. **WARNING: DO NOT** use any blade other than those recommended for this machine.
  - ▲ **DANGER - ALWAYS** disconnect the machine from the electric supply before attempting any maintenance or cleaning.
  - 7.2.1. Lock both sliding locks to stabilise the head.
  - 7.2.2. Raise and lock the head.
  - 7.2.3. Loosen the cap screw which secures the moving blade guard (fig.8) until the moving guard is released.
  - 7.2.4. Loosen the cross head screw that holds the blade guard in place in order that the plate can be rotated.
  - 7.2.5. Pull the guard release lever (fig.10) and lift the moving guard to reveal the blade screw (fig.9).
  - 7.2.6. Engage the spindle lock (fig.10) and, using a hex key, undo the bolt holding the saw blade (fig.9). **NOTE:** This is a left-hand thread.
  - 7.2.7. Remove the external washer and blade.
  - 7.2.8. Smear the inner faces of the washers with a small amount of oil and mount the new blade on the spindle between the washers.
  - 7.2.9. Ensure that the new blade is fitted with direction of rotation matching the arrow on the blade guard.
  - 7.2.10. Tighten the blade securing nut and refit the guard, checking that it has full and free movement.
  - 7.2.11. Run the machine to check that the blade is true.
- 7.3. **GENERAL MAINTENANCE**
  - 7.3.1. Check all fastenings at regular intervals and tighten if necessary.
  - 7.3.2. Pay particular attention to the blade screw, ensuring that the nut is tight.
  - 7.3.3. Lubricate the slides lightly at regular intervals.
  - 7.3.4. Check that the blade is perpendicular, as in section 6.3., at regular intervals.
- 7.4. **CLEANING**
  - 7.4.1. Keep the ventilation grilles clear of dust. Clean with a soft brush regularly.
  - 7.4.2. Brush sawdust and wood chips from the bed and head regularly.
  - 7.4.3. Clean the motor housing with a moist, soapy cloth. **DO NOT** use abrasive or solvent cleaners.



### WEEE REGULATIONS

Dispose of this product at the end of its working life in compliance with the EU Directive on Waste Electrical and Electronic Equipment (WEEE). When the product is no longer required, it must be disposed of in an environmentally protective way. Contact your local solid waste authority for recycling information.



### ENVIRONMENT PROTECTION

Recycle unwanted materials instead of disposing of them as waste. All tools, accessories and packaging should be sorted, taken to a recycling centre and disposed of in a manner which is compatible with the environment. When the product becomes completely unserviceable and requires disposal, drain any fluids (if applicable) into approved containers and dispose of the product and fluids according to local regulations.

**Note:** It is our policy to continually improve products and as such we reserve the right to alter data, specifications and component parts without prior notice. Please note that other versions of this product are available. If you require documentation for alternative versions, please email or call our technical team on [technical@sealey.co.uk](mailto:technical@sealey.co.uk) or 01284 757505.

**Important:** No Liability is accepted for incorrect use of this product.

**Warranty:** Guarantee is 12 months from purchase date, proof of which is required for any claim.

Sealey Group, Kempson Way, Suffolk Business Park, Bury St Edmunds, Suffolk. IP32 7AR



01284 757500



01284 703534



[sales@sealey.co.uk](mailto:sales@sealey.co.uk)



[www.sealey.co.uk](http://www.sealey.co.uk)