



# MOTORCYCLE BEARING & SEALS INSTALLATION KIT

MODEL NO: **SMC58**

Thank you for purchasing a Sealey product. Manufactured to a high standard, this product will, if used according to these instructions, and properly maintained, give you years of trouble free performance.

**IMPORTANT:** PLEASE READ THESE INSTRUCTIONS CAREFULLY. NOTE THE SAFE OPERATIONAL REQUIREMENTS, WARNINGS & CAUTIONS. USE THE PRODUCT CORRECTLY AND WITH CARE FOR THE PURPOSE FOR WHICH IT IS INTENDED. FAILURE TO DO SO MAY CAUSE DAMAGE AND/OR PERSONAL INJURY AND WILL INVALIDATE THE WARRANTY. KEEP THESE INSTRUCTIONS SAFE FOR FUTURE USE.



Refer to  
instructions



Wear eye  
protection

## 1. SAFETY

- ❑ **WARNING!** Ensure Health & Safety, local authority, and general workshop practice regulations are adhered to when using this equipment.
- ❑ **WARNING!** Always wear approved eye protection when using the driver. Failure to do so may result in serious injury. Normal spectacles are not adequate protection.
- ✓ Familiarise yourself with the specific applications and limitations of the driver, as well as any potential hazards.
- ✓ If unsure of the applications or limitations of the driver, contact your supplier.
- ✓ Ensure that the driver is the correct tool for the task. **DO NOT** use the driver for any purpose other than that for which it is designed.
- ✓ Replace or repair damaged parts. Use genuine parts only. Unauthorised parts may be dangerous and will invalidate the warranty.
- ✓ Ensure that the workpiece is stable and that there is adequate lighting.
- ✓ Maintain correct balance and footing. Ensure the floor is not slippery and wear non-slip shoes.
- ✓ Use the correct size and type of hammer for the task. The recommended diameter of hammer face is 10mm larger than tool head.
- ✓ Check that the hammer shaft is in good order and is firmly secured in the hammer head. Note that for seal installation a soft-faced hammer should be adequate and will be less likely to damage the tool.
- ✓ Make sure that the face of the hammer and the head of the tool are clean and free from grease, oil, etc.
- ✓ Position the tool so that it is struck away from your body.
- ✓ Strike the driver squarely on the head - **DO NOT** hit the tool off centre, or at an angle (fig.1).
- ✗ **DO NOT** use the driver if it is bent, chipped, has a mushroom head, or is otherwise damaged (fig.2).
- ✗ **DO NOT** strike the side of the driver body (fig.3).
- ✗ **DO NOT** use driver if any parts are damaged or missing as this may cause failure and/or personal injury.
- ✗ **DO NOT** use the driver when you are tired or under the influence of alcohol, drugs or intoxicating medication.
- ✓ Keep children and unauthorised persons away from the working area.
- ✓ When not in use, pack into the case, and store in a safe, dry, childproof location.

## 2. INTRODUCTION

Eases the installation of bearing and seals for the majority of motorcycles. Spreads the force evenly across the bearing/seal to prevent damage to the housing. Manufactured from machined aluminium for its strength, lightness and rust resistance. Comprehensive kit including three sizes of drive/handle and 14 sizes of adaptors. Complete with storage case for quick and easy storage.

## 3. SPECIFICATION

MODEL NO:	SMC58
Nett Weight:	0.95kg

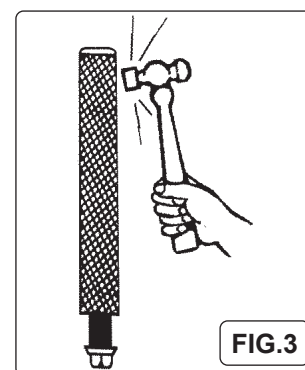
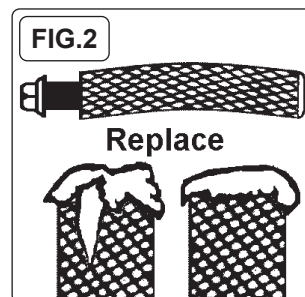
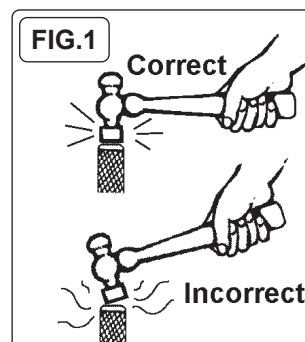

## 4. CONTENTS

Numbers refer to diagram below

**Drivers/Handles:** 11.3mm (1), 14mm (2), 16.2mm(3)

**Adapters:** 10x12mm (4), 12x14mm (5), 14x16mm (6), 15x17mm (7), 16x18mm (8), 18x20mm (9), 20x22mm (10), 22x24mm (11), 25x27mm (12), 28x30mm (13), 30x34mm (14), 32x36mm (15), 36x40mm (16), 38x42mm (17).



## 5. OPERATION

- 5.1. Select the correct adaptor (fig.4), one which is slightly smaller than the diameter of the seal/bearing race, and position it correctly on the handle.
- 5.2. Place the seal/bearing race in the mouth of the housing, place adaptor against it and tap the driver handle to force it into place.

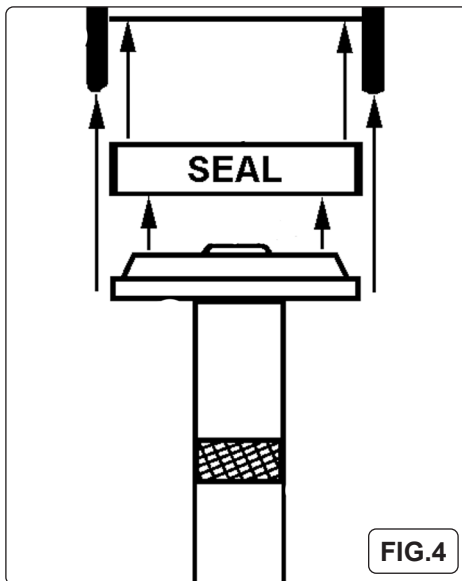

Parts support is available for this product. Please email [sales@sealey.co.uk](mailto:sales@sealey.co.uk) or telephone 01284 757500



### ENVIRONMENT PROTECTION

Recycle unwanted materials instead of disposing of them as waste. All tools, accessories and packaging should be sorted, taken to a recycling centre and disposed of in a manner which is compatible with the environment. When the product becomes completely unserviceable and requires disposal, drain any fluids (if applicable) into approved containers and dispose of the product and fluids according to local regulations.



REGISTER YOUR PURCHASE HERE

**Note:** It is our policy to continually improve products and as such we reserve the right to alter data, specifications and component parts without prior notice.

**Important:** No Liability is accepted for incorrect use of this product.

**Warranty:** Guarantee is 12 months from purchase date, proof of which is required for any claim.

Sealey Group, Kempson Way, Suffolk Business Park, Bury St Edmunds, Suffolk. IP32 7AR



01284 757500



[sales@sealey.co.uk](mailto:sales@sealey.co.uk)



[www.sealey.co.uk](http://www.sealey.co.uk)