



INSTRUCTIONS FOR

# COMPACT AUTO DIGITAL BATTERY CHARGER 9 - CYCLE 12V

MODEL NO: **SMC04.V2**

Thank you for purchasing a Sealey product. Manufactured to a high standard, this product will, if used according to these instructions, and properly maintained, give you years of trouble free performance.

**IMPORTANT:** PLEASE READ THESE INSTRUCTIONS CAREFULLY. NOTE THE SAFE OPERATIONAL REQUIREMENTS, WARNINGS & CAUTIONS. USE THE PRODUCT CORRECTLY AND WITH CARE FOR THE PURPOSE FOR WHICH IT IS INTENDED. FAILURE TO DO SO MAY CAUSE DAMAGE AND/OR PERSONAL INJURY AND WILL INVALIDATE THE WARRANTY. KEEP THESE INSTRUCTIONS SAFE FOR FUTURE USE.



Refer to instructions



Wear eye protection



Wear protective gloves



Electrical shock hazard



Warning: corrosive substance



Warning: explosive material



Keep away from sources of ignition

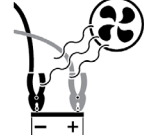

Use in well ventilated areas



Keep in dry area protect from rain

## 1. SAFETY

### Electrical Safety

- ❑ **WARNING!** It is the user's responsibility to check the following:  
Check all electrical equipment and appliances to ensure that they are safe before using. Inspect power supply leads, plugs and all electrical connections for wear and damage. Sealey recommend that an RCD (Residual Current Device) is used with all electrical products. You may obtain an RCD by contacting your local Sealey dealer.  
If the charger is used in the course of business duties, it must be maintained in a safe condition and routinely PAT (Portable Appliance Test) tested.  
Electrical safety information, it is important that the following information is read and understood.
  - ✓ Ensure that the insulation on all cables and on the appliance is safe before connecting it to the power supply.
  - ✓ Regularly inspect power supply cables and plugs for wear or damage and check all connections to ensure that they are secure.
  - ✓ Ensure that the voltage rating on the appliance suits the power supply to be used and that the plug is fitted with the correct fuse - see fuse rating in these instructions.
  - \* **DO NOT** pull or carry the appliance by the power cable.
  - \* **DO NOT** pull the plug from the socket by the cable. Remove the plug from the socket by maintaining a firm grip on the plug.
  - \* **DO NOT** use worn or damaged cables, plugs or connectors. Ensure that any faulty item is repaired or replaced immediately by a qualified electrician.  
This product is fitted with a BS1363/A 13 Amp 3 pin plug.  
If the cable or plug is damaged during use, switch the electricity supply and remove from use.  
Replace a damaged plug with a BS1363/A 13 Amp 3 pin plug. If in doubt contact a qualified electrician.
- Class II products are wired with live (brown) and neutral (blue) only and are marked with The Class II symbol;
- 
- A) Connect the BROWN live wire to the live terminal 'L'.
  - B) Connect the BLUE neutral wire to the neutral terminal 'N'.
  - C) After wiring, check that there are no bare wires and ensure that all wires have been correctly connected. Ensure that the cable outer sheath extends inside the cable restraint and that the restraint is tight.
  - \* **DO NOT** connect either wire to the earth terminal.  
Sealey recommend that repairs are carried out by a qualified electrician.

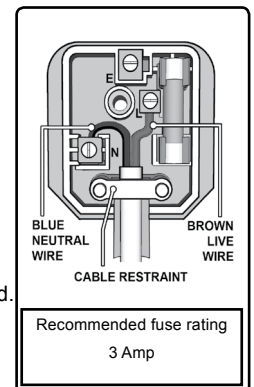

- ▲ **DANGER! BE AWARE, LEAD-ACID BATTERIES GENERATE EXPLOSIVE GASES DURING NORMAL BATTERY OPERATION. FOR THIS REASON, IT VERY IMPORTANT TO READ AND FOLLOW THESE INSTRUCTIONS CAREFULLY, EACH TIME YOU USE THE CHARGING EQUIPMENT.**
- ✓ Follow these instructions and those published by the battery and vehicle manufacturers, and the maker of any equipment you intend to use in the vicinity of the battery. Remember to review warning marks on all products and on engines.
- ❑ **WARNING!** Modern vehicles contain extensive electronic systems.  
You are required to check with the vehicle Manufacturer, for any specific instructions regarding the use of this type of equipment on each vehicle.  
No liability will be accepted for damage / injury, where this product is not used in accordance with all instructions.

### 1.1. Personal Precautions

- ✓ Ensure there is another person within hearing range of your voice and close enough to come to your aid, should a problem arise when working near a lead-acid battery.
- ✓ Wear safety eye protection and protective clothing. Avoid touching eyes while working near battery.
- ✓ Have fresh water and soap nearby in case battery acid contacts skin, clothing or eyes.
- ✓ Wash immediately with soap and water if battery acid contacts skin or clothing. If acid enters eye, flush eye immediately with cool, clean running water for at least 15 minutes and seek immediate medical attention.
- ✓ Remove personal metallic items such as rings, bracelets, necklaces and watches. A lead-acid battery can produce a short-circuit current which is high enough to weld a ring or the like to metal, which would cause severe burns.
- ✓ Ensure hands, clothing (especially belts) are clear of fan blades and other moving or hot parts of engine, remove ties and contain long hair.
- ✗ **DO NOT** smoke or allow a spark or flame in the vicinity of battery or engine.

### 1.2. General Safety Instructions

- ✓ Familiarise yourself with the application and limitations of the charger as well as the potential hazards. Also refer to the vehicle manufacturer's hand book. **IF IN ANY DOUBT CONSULT A QUALIFIED ELECTRICIAN.**
- ✓ Ensure the charger is in good order and condition before use. If in any doubt do not use the unit, contact your Sealey Dealer.
- ✓ Use the charger in the upright position only and ensure it is placed on a stable surface which will adequately support its weight.
- ✓ Ensure the charger is disconnected from the mains supply before attaching/detaching the power clamps to/from the battery.
- ✓ Keep tools and other items away from the engine and ensure you can see the battery and working parts of engine clearly.
- ✓ Ensure the output of the charger is the same voltage as the battery.
- ✓ Ensure that during charging, the charger is placed in a location where there is sufficient ventilation to prevent the build up of explosive gases from a lead acid battery, and **DO NOT** cover or obstruct the charger ventilation louvres.
- ✓ If battery has caps to access the battery fluid, remove the caps and check the fluid level before connecting the power clamps. If necessary top-up the battery with distilled water by referring to the battery manufacturer's instructions (Apply the personal safety precautions described in part 1.2).
- ✓ If the charger receives a sharp knock or blow the unit must be checked by a qualified service agent before using.
- ✓ If the battery terminals are corroded or dirty clean them before attaching the power clamps.
- ✓ Keep children and unauthorised persons away from the working area.
- ✗ **DO NOT** dis-assemble the charger for any reason. The charger must only be checked by qualified service personnel.
- ✗ **DO NOT** try to charge a non-rechargeable battery.
- ✗ **DO NOT** try to start engine when charger is connected to battery.
- ✗ **DO NOT** try to charge battery if battery fluid is frozen.
- ☐ **WARNING!** To prevent the risk of sparking, short circuit and possible explosion **DO NOT** drop metal tools in the battery area, or allow them to touch the battery terminals.
- ✗ **DO NOT** allow power clamps to touch each other or to make contact with any metallic part of the vehicle.
- ✗ **DO NOT** cross connect power leads from charger to battery. Ensure positive (+/RED) is to positive and negative (-/BLACK) is to negative.
- ✗ **DO NOT** pull the cables or clamps from the battery terminals.
- ✗ **DO NOT** use the charger outdoors, or in damp, or wet locations and **DO NOT** operate within the vicinity of flammable liquids or gases.
- ✗ **DO NOT** use charger inside vehicle or inside engine compartment.
- ✓ Ensure there is effective ventilation to prevent a build-up of explosive gases, and do not cover or obstruct charger ventilation louvres.
- ✗ **DO NOT** use the charger for a task for which it is not designed.
- ☐ **WARNING! DO NOT** simultaneously charge batteries of different capacities or discharge levels.
- ☐ **WARNING! DO NOT** charge a frozen battery.
- ☐ **WARNING!** If a fuse blows, ensure it is replaced with an identical fuse type and rating. Use only Sealey genuine parts.
- ✓ When not in use, store the charger carefully in a safe, dry, childproof location.  
**NOTE:** This appliance can be used by children aged from 8 years and above and persons with reduced physical, sensory or mental capabilities or lack of experience and knowledge if they have been given supervision or instruction concerning use of the appliance in a safe way and understand the hazards involved. Children shall not play with the appliance. Cleaning and user maintenance shall not be made by children without supervision.

## 2. INTRODUCTION

Fully automatic multi-cycle switch mode chargers and maintainers designed for charging a variety of batteries: SLA, WET, AGM/GEL and VRLA. Know exactly how the charger is performing the LED display indicates charging or maintenance phase. Charges will recover slightly sulphated batteries and may rescue drained batteries. Supplied with multi fit charger cables featuring crocodile clips, vehicle accessory socket plug and hard-wired terminals incorporating a water tight plug and socket for permanent installation - great for motorcycles and cars

## 3. SPECIFICATION

Model No.....	SMC04.V2
Type .....	9-Cycle 12V
Input.....	230V
Output .....	12V
Input Current .....	0.45A
Efficiency.....	>80%
Charging Current.....	.8A
Back Current Drain.....	<1Ah/month
Ambient Temperature .....	-20°C to +50°C
Dimensions (LxWxH) .....	233x82x46.5mm
Housing Protection.....	IP44
Weight.....	1.07kg

## 4. OPERATION

### 4.1. Cables / Connectors

**NOTE:** the charger should be connected to the battery or the vehicle accessory socket, before connecting to the mains supply.

- 4.1.1. The output cable from the charger terminates in a socket into which three alternative leads can be connected. fig.1.
- 4.1.2. One lead set (A) has two colour coded battery clamps which can be quickly attached to and detached from the battery posts. The other end of the cable terminates with a plug for connection to the charger lead socket.
- 4.1.3. The second lead (B) can be connected to the vehicle via the vehicle accessory socket. The other end of the cable terminates with a plug for connection to the charger lead socket.
- The third lead (C) is for semi permanent connection to the battery via eyelets. The other end of the cable terminates with a plug for connection to the charger lead socket.
- 4.1.4. The fourth lead (D) offers an opportunity of a power supply for 12 volt appliances fitted with a vehicle accessory plug. The other end of the cable terminates with a plug for connection to the charger lead socket.

### 4.2. Charging a negative earthed battery

- 4.2.1. Ensure that the black clamp on the clamp lead is not touching the battery or the fuel line.
- 4.2.2. Connect the positive (+) red clamp to the positive (+) battery post and connect the negative (-) black clamp to the negative (-) battery post or vehicle chassis.

### 4.3. Charging a positive earthed battery

- 4.3.1. Ensure that the red clamp on the clamp lead is not touching the battery or the fuel line.
- 4.3.2. Connect the negative (-) black clamp to the negative (-) battery post and connect the positive (+) red clamp to the positive (+) battery post or vehicle chassis.

### 4.4. Battery not connected to a vehicle

- 4.4.1. Connect the (+) red clamp to the positive (+) battery post and connect the (-) black clamp to the negative (-) battery post.

### 4.5. Permanent connection to vehicle using eyelet lead

- 4.5.1. Connect the eyelet on the red (+) wire to the positive (+) battery terminal and connect the eyelet on the black (-) wire to the negative (-) battery terminal.

### 4.6. Connect charger to mains power supply.

- 4.6.1. Plug the charger into the mains power supply and switch on. The green power LED will illuminate. fig.2.

### 4.7. Charging mode selection.

- 4.7.1. Repeatedly pressing the MODE button will cycle the charger through the following options:- MODE1, MODE2, MODE3, MODE4 and MODE5. Stop pressing when the LED adjacent to the desired mode illuminates.
- 4.7.2. If the Mode button is pressed again during charging the charger will switch to the next charging mode and will function in that mode. However, once the battery is fully charged and if the charger remains connected, the charger will switch to trickle charge mode and will remain in this mode even if the user selects another mode. This protects the battery from being damaged.

### 4.8. MODE 1 DESCRIPTION (\*14.4v/2.0A)

- 4.8.1. This mode is suitable for charging small batteries with a capacity below 40Ah. Press the MODE button until the LED adjacent to the motorcycle symbol is illuminated. Charging will automatically begin with a current of  $0.8A \pm 10\%$  and the 'charging' LED will illuminate. This LED will remain on throughout the entire charging process until the battery is fully charged up to  $*14.4V \pm 0.25V$ . At this stage the 'charging' LED will illuminate and the 'fully charged' LED will extinguish. The trickle charge current now becomes available for battery maintenance.

### 4.9. MODE 2 DESCRIPTION (\*14.4v/8.0A)

- 4.9.1. This mode is mainly for charging large batteries with a capacity over 160Ah in normal conditions. Press the MODE button until the LED adjacent to the car symbol is illuminated. Charging will automatically begin with a current of  $3.8A \pm 10\%$  and the 'charging' LED will illuminate. This LED will remain on throughout the entire charging process until the battery is fully charged up to  $*14.4V \pm 0.25V$ . At this stage the 'charging' LED will turn off and the 'fully charged' LED will illuminate. The trickle charge current now becomes available for battery maintenance.

### 4.10. MODE 3 DESCRIPTION (\*14.7/8.0A)

- 4.10.1. This mode is mainly for charging large batteries with a capacity over 14Ah in cold conditions or for charging several AGM batteries with a capacity over 20Ah. Press the MODE button until the LED adjacent to the ice crystal symbol is illuminated. Charging will automatically start with a set delay with a current of  $3.8A \pm 10\%$  and the 'charging' LED will illuminate. This LED will remain on throughout the entire charging process until the battery is fully charged up to  $*14.7V \pm 0.25V$ . At this stage the 'charging' LED will extinguish and the 'fully charged' LED will illuminate. The trickle charge current now becomes available for battery maintenance.

### 4.11. MODE 4 DESCRIPTION (Cal)

- 4.11.1. This mode is for lead calcium or a battery below 10.5 volts with no capacity to absorb charging current, the charger will automatically raise the output voltage up to 17 volts. The Mode 4 LED will illuminate and flash, the charging LED will

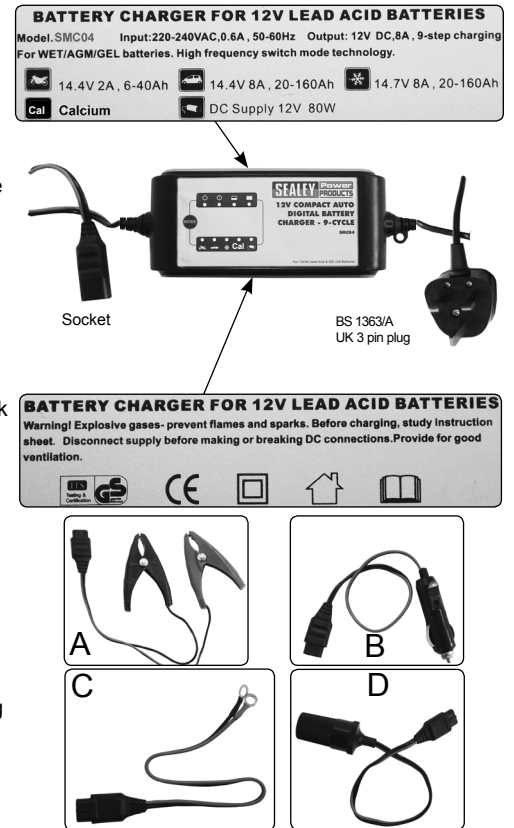

fig.1

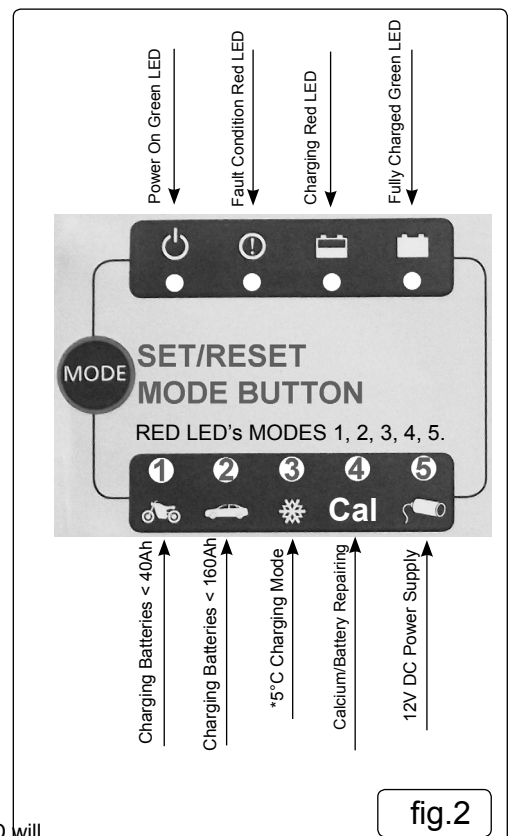

fig.2

illuminate. If the battery can not be recovered within 2 hours the "Fault" (!) LED will illuminate. The battery may require replacing.

4.12. **MODE 5 DESCRIPTION(13.5v 5amp output)**

4.12.1. A DC power supply for use with 12 volt appliances fitted with a vehicle accessory plug. Maximum output power is 80 watts.

4.13. **FAULT PROTECTION**

4.8.1 In the case of a short circuit, open circuit, or reversed polarity, the charger will turn off the electronic system and revert to standby mode. Additionally the "Fault" (!) LED will illuminate. The fault must be identified and resolved before any of the charging modes are initiated.

4.14. **OVERHEATING PROTECTION**

4.14.1. If the charger becomes too hot during the charging process or due to extreme ambient temperatures the power output is automatically reduced to a trickle charge to protect the unit. Once the temperature drops the charger will increase the power output automatically.

**5. DESCRIPTION OF CHARGING PHASES**

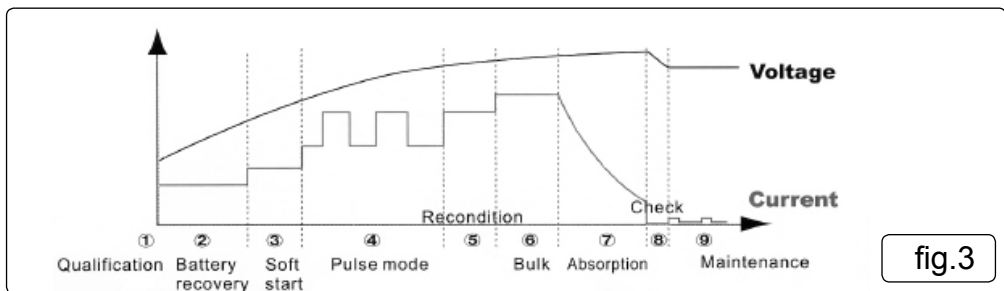

fig.3

- 5.1. The SMC04.V2 charger has a nine step fully automatic charging cycle as shown fig.3, which is indicative of the typical charging curve for a battery.
- 5.2. PHASE 1 through 5 DIAGNOSIS & RECOVERY: As soon as one of the charging modes is selected the diagnostic function automatically detects the condition of the battery i.e. voltage. If the voltage of a deeply discharged battery is over  $*7.5V \pm 0.5V$  the charger begins to pulse charge with a small current to recover it. Pulse charging ceases when the voltage reaches  $*10.5V \pm 0.5V$ . If the voltage detected is over  $*10.5V \pm 0.5V$  the charger skips pulse charging and switches to the preselected charging mode.
- 5.3. PHASE 6 BULK: Up to 80% of the charge is delivered in this phase.
- 5.4. PHASE 7 ABSORPTION: A constant low charging current raises the voltage from  $*14.1V$  to  $14.4V$  over a period of time without gasing the battery. In this phase complete charging up to almost 100% is achieved. When full charge is reached the charger switches to phase 8 and 9.
- 5.5. PHASE 8 & 9 MAINTENANCE CHARGE: If the battery is loaded and/or the voltage across the terminals drops below  $*12.8V$ , the charger starts a maintenance charging pulse at a constant 0.8A until the voltage reaches  $*14.4V$  at which point the maintenance charge is turned off. The charger continues to monitor the battery condition and will cycle between trickle charge and maintenance charge indefinitely to keep the battery in peak condition. The charger can be left connected to the battery in order to perform this maintenance function.  
**Note!** Figures marked thus \* are for 12 volt batteries and all figures are offered as a guide only. The charger is automatic and requires no measurements by the user.

**6. MAINTENANCE**

- 6.1. This charger requires no specific maintenance other than cleaning which should be done with a dry cloth or a tissue. **DO NOT** use any solvents or cleaning agents on the casing.
- 6.2. Ensure that the charger is unplugged from the mains before installing or performing any maintenance.

**Parts support is available for this product. To obtain a parts listing and/or diagram, please log on to [www.sealey.co.uk](http://www.sealey.co.uk), email [sales@sealey.co.uk](mailto:sales@sealey.co.uk) or telephone 01284 757500.**



**Environmental Protection**

Recycle unwanted materials instead of disposing of them as waste. All tools, accessories and packaging should be sorted, taken to a recycling centre and disposed of in a manner which is compatible with the environment. When the product becomes completely unserviceable and requires disposal, drain off any fluids (if applicable) into approved containers and dispose of the product and the fluids according to local regulations.



**WEEE Regulations**

Dispose of this product at the end of its working life in compliance with the EU Directive on Waste Electrical and Electronic Equipment (WEEE). When the product is no longer required, it must be disposed of in an environmentally protective way. Contact your local solid waste authority for recycling information.

**NOTE:** It is our policy to continually improve products and as such we reserve the right to alter data, specifications and component parts without prior notice.

**IMPORTANT:** No liability is accepted for incorrect use of this product.

**WARRANTY:** Guarantee is 12 months from purchase date, proof of which will be required for any claim.



Sole UK Distributor, Sealey Group.  
 Kempson Way, Suffolk Business Park,  
 Bury St. Edmunds, Suffolk.  
 IP32 7AR



01284 757500



01284 703534



[www.sealey.co.uk](http://www.sealey.co.uk)



[sales@sealey.co.uk](mailto:sales@sealey.co.uk)