



1/2" HOLLOW CHISEL MORTISER

MODEL NO: **SM94.V5**

Thank you for purchasing a Sealey product. Manufactured to a high standard, this product will, if used according to these instructions, and properly maintained, give you years of trouble free performance.

IMPORTANT: PLEASE READ THESE INSTRUCTIONS CAREFULLY. NOTE THE SAFE OPERATIONAL REQUIREMENTS, WARNINGS & CAUTIONS. USE THE PRODUCT CORRECTLY AND WITH CARE FOR THE PURPOSE FOR WHICH IT IS INTENDED. FAILURE TO DO SO MAY CAUSE DAMAGE AND/OR PERSONAL INJURY AND WILL INVALIDATE THE WARRANTY. KEEP THESE INSTRUCTIONS SAFE FOR FUTURE USE.



Refer to instructions



Wear eye protection



Wear protective gloves



Wear safety footwear



Wear a mask

1. SAFETY

1.1. ELECTRICAL SAFETY

- ❑ **WARNING!** It is the responsibility of the owner and the operator to read, understand and comply with the following:
You must check all electrical products, before use, to ensure that they are safe. You must inspect power cables, plugs, sockets and any other connectors for wear or damage. You must ensure that the risk of electric shock is minimised by the installation of appropriate safety devices. A Residual Current Circuit Breaker (RCCB) should be incorporated in the main distribution board. We also recommend that a Residual Current Device (RCD) is used. It is particularly important to use an RCD with portable products that are plugged into a supply which is not protected by an RCCB. If in any doubt consult a qualified electrician. You may obtain a Residual Current Device by contacting your Sealey stockist.

You must also read and understand the following instructions concerning electrical safety.

The Electricity at Work Act 1989 requires that all portable electrical appliances, if used on business premises, are tested by a qualified electrician, using a Portable Appliance Tester (PAT), at least once a year.

The Health & Safety at Work Act 1974 makes owners of electrical appliances responsible for the safe condition of those appliances and the safety of the appliance operators. If in any doubt about electrical safety, contact a qualified electrician.

1.1.1. Ensure that the insulation on all cables and on the appliance is safe before connecting it to the power supply.

1.1.2. Ensure that cables are always protected against short circuit and overload.

1.1.3. Regularly inspect power supply cables and plugs for wear or damage and check all connections to ensure that none is loose.

1.1.4. Ensure that the voltage marked on the appliance matches the power supply to be used and that the plug is fitted with the correct fuse - see plug diagram on right.

- × **DO NOT** pull or carry the appliance by the power cable.

- × **DO NOT** pull the plug from the socket by the cable.

- × **DO NOT** use worn or damaged cables, plugs or connectors. Immediately have any faulty item repaired or replaced by a qualified electrician. When a BS 1363/A UK 3 pin plug is damaged, cut the cable just above the plug and dispose of the plug safely.

Fit a new plug according to the following instructions (UK only).

a) Connect the GREEN/YELLOW earth wire to the earth terminal 'E'.

b) Connect the BROWN live wire to the live terminal 'L'.

c) Connect the BLUE neutral wire to the neutral terminal 'N'.

Ensure that the cable outer sheath extends inside the cable restraint and that the restraint is tight.

Sealey recommend that repairs are carried out by a qualified electrician.

1.2. GENERAL SAFETY

- ❑ **WARNING!** Disconnect the mortiser from the mains power before changing accessories, servicing or performing any maintenance. Locate the mortiser in a suitable working area. Fasten the mortiser to a strong flat working surface. Keep area clean and tidy and free from unrelated materials and ensure there is adequate lighting.
- ✓ Maintain the mortiser in good condition (use an authorised service agent).
- ✓ Replace or repair damaged parts. Use genuine parts only. Unauthorised parts may be dangerous and will invalidate the warranty.
- ✓ Keep the mortiser clean for best and safest performance and check moving parts alignment regularly.
- ✓ Keep mortiser tool bits clean and sharp and ensure bit is secured correctly in the mortiser chuck. If worn or damaged replace immediately.
- ✓ Remove adjusting keys and wrenches from the mortiser and its vicinity before turning it on.
- ✓ Wear approved eye safety protection.
- ✓ Handle loose chisels and drill bits with gloves or cloth as they are very sharp, but **DO** remove gloves and/or cloth before operating the mortiser. Keep your hands and fingers away from the mortiser tool bit and chisel when operating.
- ✓ Remove ill fitting clothing. Remove ties, watches, rings and other loose jewellery, and contain long hair.
- ✓ Maintain correct balance and footing. Ensure the floor is not slippery and wear non-slip shoes.
- ✓ Secure work piece by resting against the back stop and top holding clamp.
- ✓ Ensure there are no foreign objects in the workpiece i.e. nails or screws.
- ✓ Use the depth stop for accuracy and to avoid drilling into the work table, and avoid unintentional starting.
- × **DO NOT** start the mortiser with the tool bit resting against the workpiece. Always bring the operating chisel to the workpiece.
- × **DO NOT** attempt to place a workpiece on the mortiser table whilst the cutting tool is working.

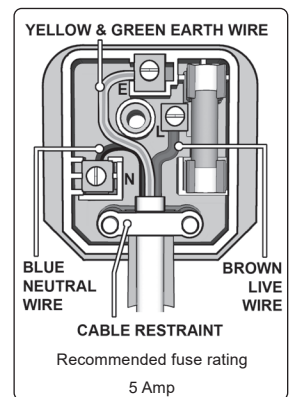

- × **DO NOT** use the mortiser for a task it is not designed to perform.
- × **DO NOT** allow untrained persons to operate the mortiser and keep children and unauthorised persons away from the working area.
- × **DO NOT** get the mortiser wet or use in damp or wet locations or areas where there is condensation.
- × **DO NOT** use mortiser where there are flammable liquids, solids or gases such as paint solvents, waste wiping rags etc.
- × **DO NOT** operate the mortiser if any parts are damaged or missing as this may cause failure and/or possible personal injury.
- × **DO NOT** leave the mortiser operating unattended.
- × **DO NOT** operate the mortiser when you are tired or under the influence of alcohol, drugs or intoxicating medication.
- × When not in use switch off the mortiser and remove plug from the power supply.

2. INTRODUCTION

Suitable for cutting mortises for joints, locks and dead-bolts. Twin uprights with hydraulic damper carry head assembly and have adjustable depth stop for repetitive work. Heavy-duty induction motor with no-volt release switch to prevent accidental restart after power failure or jam. Supplied with arbor extension, 13mm drill chuck and mortising chisels. Includes table and workpiece clamp. Recommended height of work item is at least 55mm for secure placement in clamp.

3. SPECIFICATION

MODEL NO.:SM94.V5
Motor Power:370W-230V
Chisel Capacity: 6 - 12mm
Chuck Capacity:13mm
Dimensions:340 x 355 x 640mm
Spindle Speed: 1400rpm
Spindle Travel:132mm
Table Size:340 x 150mm
Throat Depth:76mm

4. ASSEMBLY

- ❑ **WARNING! DO NOT** plug the mortiser into the mains power supply until completely assembled and these instructions tell you to do so.
- × **DO NOT** allow brake fluids, petroleum, penetrating oils etc. to come into contact with plastic parts of mortiser as damage may result.
- ❑ **WARNING!** The mortiser is delivered with the head positioned low down on the two pillars and is held in this position by a piece of wood inserted between the top of the head and the crosspiece on top of the pillars. Care must be taken when removing this piece of wood as the head is held under spring pressure and will move rapidly to the top of the pillars when the wood is removed.

- 4.1. **RELEASING THE HEAD & HANDLE ASSY.** Place the mortiser onto a firm, solid workbench and bring the cast base near to the front edge of the work surface. Assemble handle sleeve (fig.2.A) to pinion shaft (fig.2.B) using the spring and screw arrangement (fig.2.C, fig.2.D). Insert the threaded end of the handle (fig.1.D) through the hole in the sleeve (fig.2.A) on the side of the head and fix in place using the washers, spring and nut arrangement (fig.2.F). Steady the mortiser by placing your left hand on top of the unit. Rotate the handle so that it is pointing downwards at 45°. Push the handle further down a small amount to take the pressure off the wood and get a second person to remove the piece of wood. Slowly allow the handle to rotate upwards allowing the head to move to the top of the pillars in a controlled fashion.
- 4.2. **WORK TABLE.** (fig.1.F) Attach the Work Table to the cast base using the two countersunk M8 x 25mm Table fixing screws.
- 4.3. **BACKSTOP ASSEMBLY & CLAMP** (fig.1.H, fig.1.G, fig.3)

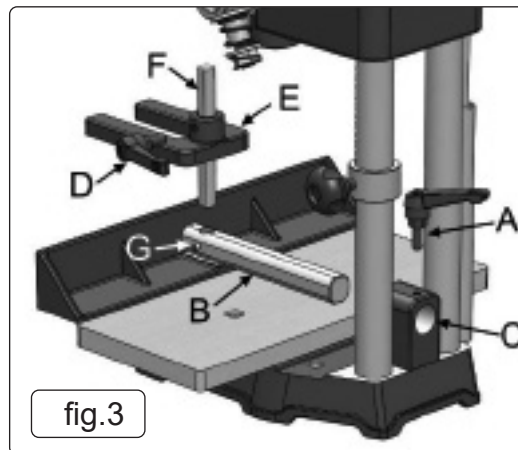
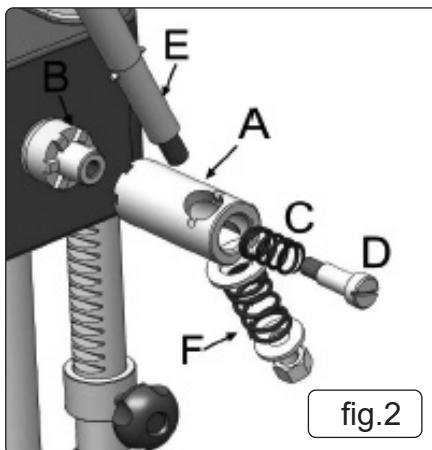
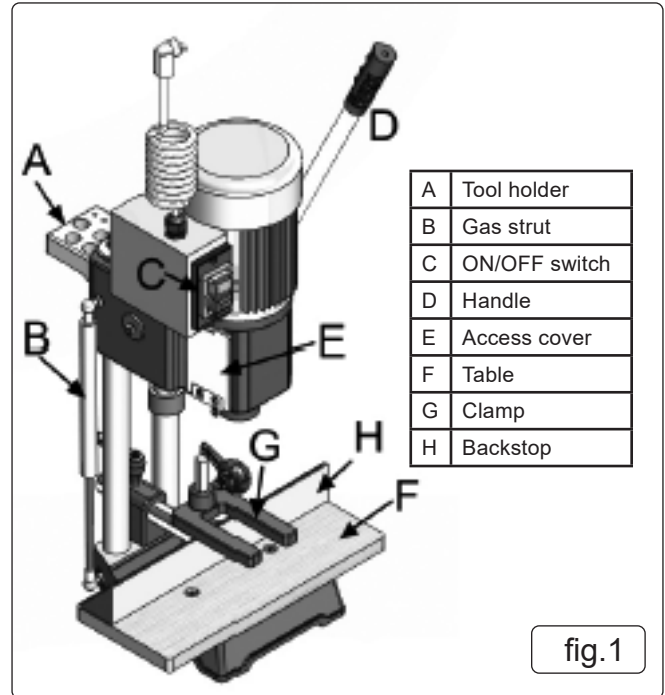

- 4.3.1. Insert fence bar (fig.3.B) to the hole (fig.3.C) and fasten by handle (fig.3.A)
- 4.3.2. Insert the clamp (fig.3.E, fig.1.G) into the hold down bar and fasten by handle (D)
- 4.3.3. Fasten the clamp assembly (fig.3.D, fig.3.E, fig.3.F) into the hole by screw (fig.3.G).

4.4. TOOL AND CHISEL HOLDER

4.4.1. Assemble tool and chisel holder (fig.1.A) to side of column using two screws supplied.

5. OPERATION

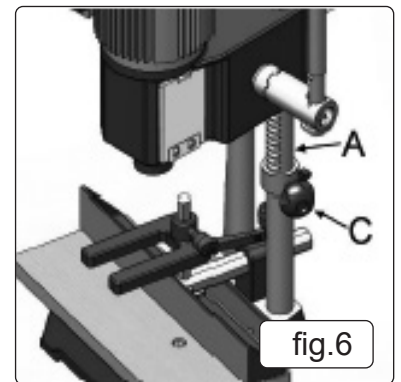
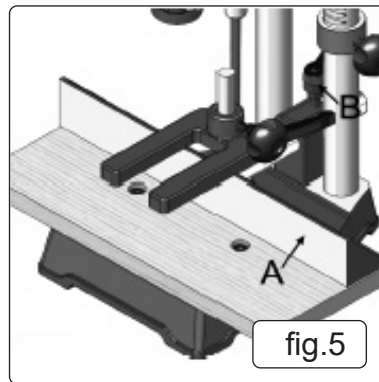
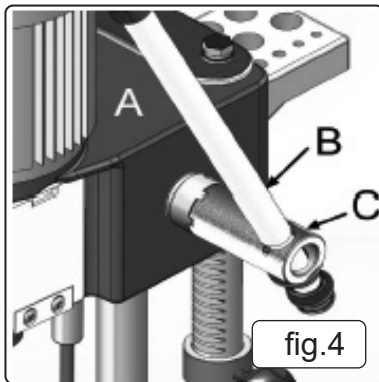

5.1. RAISING AND LOWERING THE HEAD

The head (fig.4.A) is raised and lowered by means of the lever (fig.4.B). For maximum leverage during the mortising operation, the lever (fig.4.B) can be repositioned by pulling out the hub (fig.4.C) of the lever assembly and repositioning hub on the pinion shaft.

5.2. ADJUSTING THE FENCE

The backstop (fig.5.A) can be moved in or out by loosening lever (fig.5.B), slide backstop to desired position and tighten lever (fig.5.B).

NOTE: Lever (fig.5.B) is spring-loaded and can be repositioned by pulling out on the lever and repositioning it on the serrated nut located underneath the lever.

5.3. DEPTH STOP

A depth stop guide (fig.6.A) is provided to limit the depth of the chisel. To adjust the depth stop guide (fig.6.A), loosen screw knob (fig.6.C) and lower head until the chisel is at the desired depth. Lower depth stop guide (A) until it is at the desired depth, tighten screw knob (fig.6. C).

5.4. INSTALLING CHISEL AND BIT

WARNING! Ensure the mortiser is switched off and is unplugged from the mains power supply.

WARNING! Use gloves when handling drill and chisel bits as the ends are very sharp.

NOTE: Set the slot in the side of the chisel to the left or right, NOT to the front or back. This allows chips to escape when cutting mortises.

5.4.1. Remove the access cover (fig.1.E) and loosen lock screw (fig.7).

5.4.2. Insert chisel bushing (with the hole facing forward) into the head. Tighten the screw just enough to hold the chisel in place.

5.4.3. Push the chisel up as far as possible into the head. Then lower the chisel approximately 0.8mm to 1.6mm, depending on the type of wood being worked. Tighten the screw to hold chisel in place.

5.4.4. Push bit up through the chisel opening as far as it will go. Lock the drill bit in place with the chuck key.

5.4.5. Loosen lock screw and push chisel up against the bushing, then tighten screw. This should provide the proper distance between the points of the chisel and the bit.

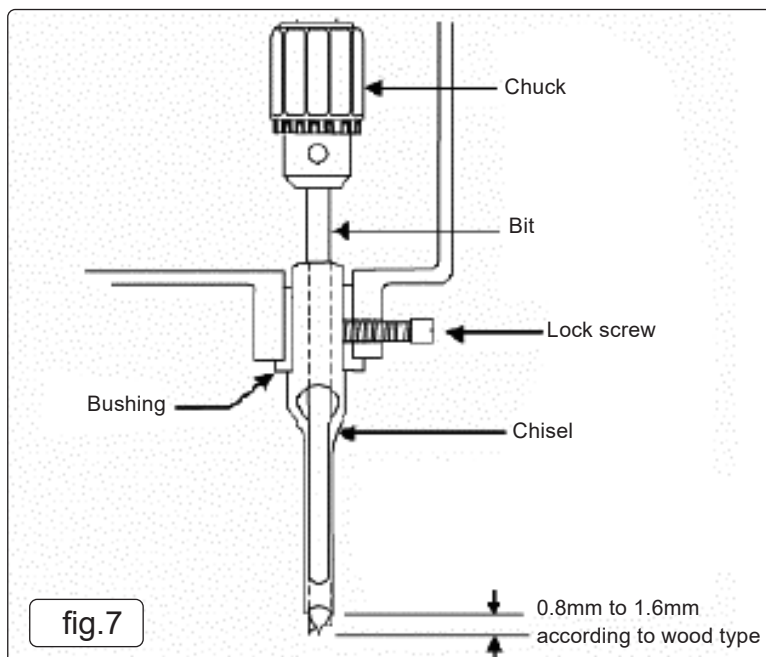

6. MAINTENANCE

- ❑ **WARNING!** Ensure the mortiser is switched off and is unplugged from the mains power supply before carrying out any maintenance.
- 6.1. Clean and dust the mortiser, removing all waste materials.
- 6.2. Periodically apply a light coat of wax to base work surface which will help keep it clean and rust free.
- 6.3. Open shaft cover and apply a thin coat of light machine oil to drill bit shaft where it passes through the chisel, but not on the cutting edge. Also lightly oil rack and pinion gear teeth upon which the main column moves up and down.

7. TROUBLESHOOTING

THE PROBLEM	THE CAUSE	THE SOLUTION
Noisy operation	Dry drill bit shaft	Lubricate drill bit shaft
Bit burns or smokes	1. Chips not coming out of hole	1. Retract bit frequently to clear chips
	2. Dull bit	2. Sharpen or replace bit
	3. Feed rate too slow	3. Feed faster
Excessive drill bit run out, or wobble	1. Bent bit	1. Replace bit
	2. Chuck not correctly installed	2. Remove chuck and install correctly
	3. Bit not correctly installed	3. Remove bit and install correctly
	4. Worn or loose chuck	4. Replace chuck
	5. Worn spindle bearings	5. Replace bearings
Drill binds in workpiece	1. Workpiece twisting or moving	1. Support or clamp workpiece
	2. Excessive feed pressure	2. Reduce pressure and clamp workpiece



ENVIRONMENT PROTECTION

Recycle unwanted materials instead of disposing of them as waste. All tools, accessories and packaging should be sorted, taken to a recycling centre and disposed of in a manner which is compatible with the environment. When the product becomes completely unserviceable and requires disposal, drain any fluids (if applicable) into approved containers and dispose of the product and fluids according to local regulations.



WEEE REGULATIONS

Dispose of this product at the end of its working life in compliance with the EU Directive on Waste Electrical and Electronic Equipment (WEEE). When the product is no longer required, it must be disposed of in an environmentally protective way. Contact your local solid waste authority for recycling information.

Note: It is our policy to continually improve products and as such we reserve the right to alter data, specifications and component parts without prior notice.

Important: No Liability is accepted for incorrect use of this product.

Warranty: Guarantee is 12 months from purchase date, proof of which is required for any claim.

Sealey Group, Kempson Way, Suffolk Business Park, Bury St Edmunds, Suffolk. IP32 7AR



01284 757500



01284 703534



sales@sealey.co.uk



www.sealey.co.uk