



# 25MM X 762MM BELT/Ø125MM DISC SANDER

MODEL NO: **SM750.V3**

Thank you for purchasing a Sealey product. Manufactured to a high standard, this product will, if used according to these instructions, and properly maintained, give you years of trouble free performance.

**IMPORTANT:** PLEASE READ THESE INSTRUCTIONS CAREFULLY. NOTE THE SAFE OPERATIONAL REQUIREMENTS, WARNINGS & CAUTIONS. USE THE PRODUCT CORRECTLY AND WITH CARE FOR THE PURPOSE FOR WHICH IT IS INTENDED. FAILURE TO DO SO MAY CAUSE DAMAGE AND/OR PERSONAL INJURY AND WILL INVALIDATE THE WARRANTY. KEEP THESE INSTRUCTIONS SAFE FOR FUTURE USE.



Refer to instruction manual



Wear eye protection



Wear a mask



Wear ear protection



Wear protective gloves

## 1. SAFETY

### ✓ **ELECTRICAL SAFETY**

- ❑ **WARNING!** It is the user's responsibility to check the following:
  - Check all electrical equipment and appliances to ensure that they are safe before using.
  - Inspect power supply leads, plugs and all electrical connections for wear and damage.
  - Ensure that the insulation on all cables and on the appliance is safe before connecting it to the power supply.
- \* **DO NOT** use worn or damaged cables, plugs or connectors.
- ✓ Ensure that any faulty item is repaired or is replaced immediately by a qualified electrician.
- ✓ If the cable or plug is damaged during use, switch off the electricity supply and remove from use.
- ✓ **Ensure that repairs are carried out by a qualified electrician.**
- ✓ Sealey recommend that an RCD (Residual Current Device) is used with all electrical products.  
**Important:** Ensure that the voltage rating on the appliance suits the power supply to be used and that the plug is fitted with the correct fuse.
- \* **DO NOT** pull or carry the appliance by the power cable.
- \* **DO NOT** pull the plug from the socket by the cable.

### **GENERAL SAFETY**

- ❑ **WARNING!** Ensure all Health and Safety, local authority, and general workshop practice regulations are strictly adhered to.
- ❑ **WARNING!** Disconnect from the mains power supply before changing accessories, servicing or performing any maintenance.
- ❑ **WARNING! DO NOT** sand any materials containing asbestos.
- ✓ Ensure the operating voltage stated on the ratings plate corresponds to your mains power supply.
- ✓ Check the belt and disc sander and the electrical connections for any damage and **DO NOT** use the tool if the sander or the cable is damaged.
- ✓ Ensure that the belt and disc sander is switched off before plugging in to the mains power supply.
- ✓ Persons with limited physical, sensory or mental abilities are not allowed to use the unit, unless they are fully supervised and briefed on safety issues by a qualified person.
- ✓ Use the belt and disc sander according to this manual and only for the purpose for which it is designed.
- ✓ Before starting up, make sure that no spanners or adjusting keys are attached to the machine.
- ✓ Avoid contact with grounded surfaces such as radiators, pipes etc.
- ✓ Maintain correct balance and footing, ensure that the floor is not slippery and wear non-slip rubber soled footwear.  
**NOTE:** Remember that the disc and belt will still be moving for several seconds whilst slowing down, **after** switching off.
- ✓ Familiar yourself with your working area and be alert for possible hazards, which you might not hear due to machine noise.
- ✓ Inspect the work piece and remove all nails and screws before sanding.
- ✓ Be aware that sparks may ignite the dust or fumes.
- ✓ Switch off the belt and disc sander before making any adjustments and when the unit is not in use.
- ✓ After finishing work and maintenance, disconnect the power lead from the mains supply.
- ✓ In the event of an electrical or mechanical malfunction, immediately switch off the sander and do not use it further.
- ✓ Always keep your work area clean.
- ✓ Never use the power cable to carry the belt and disc sander. Keep the cable away from hot, sharp edges and moving parts.
- ❑ **WARNING!** Always wear gloves and safety goggles and a dust mask as some coatings and wood dust may be harmful and toxic.
- ✓ Always work in a well ventilated area. Whenever possible use the dust collection outlets provided on the machine.
- ✓ Take care that the belt and disc sander cannot tip over or move while sanding long or heavy objects. If necessary, fasten the belt and disc sander to a supporting surface.
- ✓ Ensure that the sanding belt is running in the correct direction and ensure that the sanding disc or sanding belt is not damaged.
- \* **DO NOT** allow children or untrained persons to operate the sander. Keep them away from the work area.
- ✓ Ensure the sanding belt is correctly positioned and adjusted so that it cannot run off the pulleys.
- \* **DO NOT** remove the safety guard whilst sander is in use.
- ✓ Remove ill fitting clothing, ties and loose jewellery and tie back long hair. Keep hands and body clear of the worktable when operating the sander.
- \* **DO NOT** use the belt and disc sander near flammable liquids, gases or dust.
- \* **DO NOT** disassemble the machine and do not try to repair it yourself. Have the unit repaired by a professional or contact your local Sealey dealer. Always use original replacement parts.
- \* **DO NOT** touch the sanding belt immediately after operation; it may be extremely hot and cause burns. The sanding belt is sharp-edged.

- ✗ **DO NOT** use excessive force against the sanding belt or disc.
- ✗ **DO NOT** operate the sander when you are tired, under the influence of alcohol, drugs or intoxicating medication.
- ✗ **DO NOT** get the sander wet or use in damp or wet locations or areas where there is condensation.
- ✗ **DO NOT** switch the sander on while the workpiece is in contact with the abrasive and **DO NOT** leave the sander running unattended.
- ☐ **WARNING!** The warnings, cautions and instructions in this manual cannot cover all possible conditions and situations that may occur. It must be understood by the operator that common sense and caution are factors which cannot be built into this product, but must be applied by the operator.
- ✓ Keep work area clear: Cluttered areas and benches invite injuries. Consider your work area environment: Do not expose tools to rain
- ✗ **DO NOT** use tools in damp or wet locations. Keep work area well lit. Do not use tools in the presence of flammable liquids or gases.
- GUARD AGAINST ELECTRIC SHOCK**
- ✓ Avoid body contact with earthed or grounded surfaces.
- ✓ Keep other persons away.
- ✗ **DO NOT** let persons, especially children, not involved in the work touch the tool or the extension cord and keep them away from the work area.
- ✓ Store idle tools: When not in use, tools should be stored in a dry locked-up place, out of reach of children.
- ✗ **DO NOT** force the tool, It will do the job better and safer at the rate for which it was intended. Use the right tool:
- ✗ **DO NOT** force small tools to do the job of a heavy duty tool.
- ✗ **DO NOT** use tools for purposes not intended Dress properly.
- ✗ **DO NOT** wear loose clothing or jewellery, they can be caught in moving parts. Non-skid footwear is recommended when working outdoors. Wear protective hair covering to contain long hair. Use protective equipment: Use safety glasses. Use face or dust mask if working operations create dust.
- ✓ Connect dust extraction equipment: If the tool is provided for the connection of dust extraction and collecting equipment, ensure these are connected and properly used.
- ✗ **DO NOT** abuse the cord: Never yank the cord to disconnect it from the socket. Keep the cord away from heat, oil and sharp edges.
- ✓ Secure work: Where possible use clamps or a vice to hold the work. It is safer than using your hand.
- ✗ **DO NOT** overreach. Keep proper footing and balance at all times.
- ✓ Maintain tools with care: Keep cutting tools sharp and clean for better and safer performance. Follow instruction for lubricating and changing accessories. Inspect tool cords periodically and if damaged have them repaired by an authorised service facility.
- ✓ Inspect extension cords periodically and replace if damaged.
- ✓ Keep handles dry, clean and free from oil and grease.
- ✓ Disconnect tools: When not in use, before servicing and when changing accessories such as blades, bits and cutters, disconnect tools from the power supply. Remove adjusting keys and wrenches: Form the habit of checking to see that keys and adjusting wrenches are removed from the tool before turning it on.
- ✓ Avoid unintentional starting: Ensure switch is in off position when plugging in.
- ✓ Use outdoor extension leads: When the tool is used outdoors, use only extension cords intended for outdoor use and so marked.
- ✓ Stay alert: Watch what you are doing, use common sense and do not operate the tool when you are tired.
- ✓ Check damaged parts: Before further use of tool, it should be carefully checked to determine that it will operate properly and perform its intended function.
- ✓ Check for alignment of moving parts, binding of moving parts, breakage of parts, mounting and any other conditions that may affect its operation. A guard or other part that is damaged should be properly repaired or replaced by an authorised service centre unless otherwise indicated in this instruction manual.
- ✓ Have defective switches replaced by an authorised service centre.
- ✓ **DO NOT** use the tool if the switch does not turn it on and off.
- ☐ **WARNING!** The use of any accessory or attachment other than one recommended in this instruction manual may present a risk of personal injury. Have your tool repaired by a qualified person: This electric tool complies with the relevant safety rules. Repairs should only be carried out by qualified persons using original spare parts, otherwise this may result in considerable danger to the user.

## 2. INTRODUCTION

Bench mounting semi-portable belt and disc sander suitable for general woodworking applications. Powerful induction motor with smooth, bearing-mounted drive pulleys gives quiet operation. Sanding disc table tilts to 45° and is supplied with mitre gauge for accurate angle sanding. Sanding belt is positioned vertically.

## 3. SPECIFICATION

<b>Model No:</b> .....	<b>SM750.V3</b>
Belt Size: .....	25 x 762mm
Belt Speed: .....	845mtr/min
Disc Size: .....	125mm
Disc Speed: .....	2850rpm
Table Size: .....	128 x 185mm
Table Tilt: .....	0-45°
Motor Power: .....	250W - 230V
Supply: .....	230V
Dust Extraction: .....	2 x Ø45mm
Fuse Rating: .....	5A
Plug Type: .....	3-Pin
Table Size: .....	128 x 185mm
Table Tilt: .....	0-45°
Power Supply Cable Length: .....	1.2m
Weight: .....	7kg
<b>Replacement Sanding Belts:</b> .....	
<b>Model No:</b> .....	<b>Grade:</b>
SM750B60G .....	(Pack of 5) 60Grit
SM750B80G .....	(Pack of 5) 80Grit
SM750B120G .....	(Pack of 5) 120Grit
<b>Replacement Sanding Discs:</b> .....	
<b>Model No:</b> .....	<b>Grade:</b>
SSD01 .....	80Grit

## 4. CONTENTS

- |                            |                          |
|----------------------------|--------------------------|
| 1 Cover Clamp Knob         | 11 Sanding Disc          |
| 2 Clear Cover              | 12 On/Off (I/O) Switches |
| 3 Sanding Belt             | 13 Belt Tracking Knob    |
| 4 Sanding Belt Table       | 14 Table Levelling Screw |
| 5 Sanding Belt             | 15 2 x Cover Screws      |
| 6 Lever Locking Screw      |                          |
| 7 2 x Table Clamp Knobs    |                          |
| 8 Protractor Guide         |                          |
| 9 2 X Dust Exhaust Outlets |                          |
| 10 Sanding Disc Table      |                          |

## 5. ASSEMBLY

Unpack the sander and check contents against the list above. If there are any damaged or missing parts contact your supplier immediately!

- ❑ **WARNING!** Ensure that the sander is disconnected from the mains power supply before beginning assembly

### 5.1. ATTACHING THE SANDING DISC DUST EXTRACTOR

- 5.1.1. Attach the dust extractor plate (E) over the lower part of the sanding disc using the four screws provided as shown in fig.2.

### 5.2. ATTACHING THE SANDING DISC TABLE

- 5.2.1. On each inner curved face of the sanding table adjustment scales there is a spigot which acts as a hinge point when adjusting the angle of the table. See fig.3 (P). Hold the sanding table (T) in the position shown in fig.3 above, slide the spigots into the 'L' shaped slots either side of the sanding disc until the table stops, then lift the table up until the spigots stop at point (S) on either side. Retaining the table in this position, insert a clamping knob (K) through the curved slot in one of the sanding table adjustment scales and screw it into the threaded hole provided in the flange around the disc. Tighten the knob to hold the table in position and then screw the second knob 'K' into position on the other side of the table.
- 5.2.2. Place the adjustable, horizontal angle guide into the slot in the table when required (fig.1, Item 8) and adjust the angle as required and clamp.

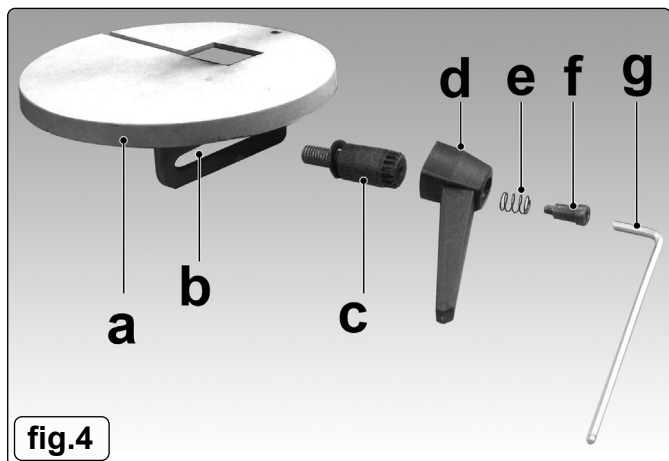
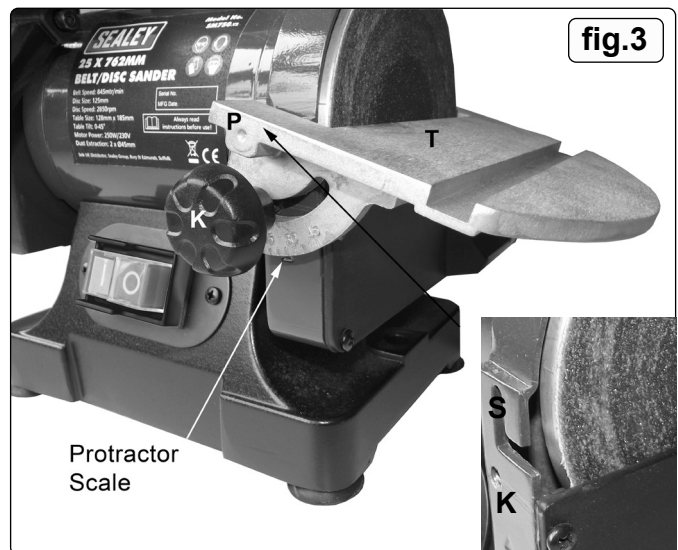
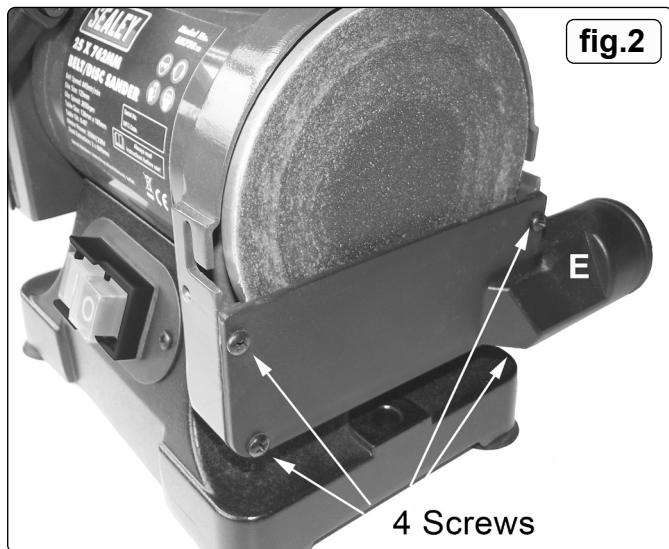
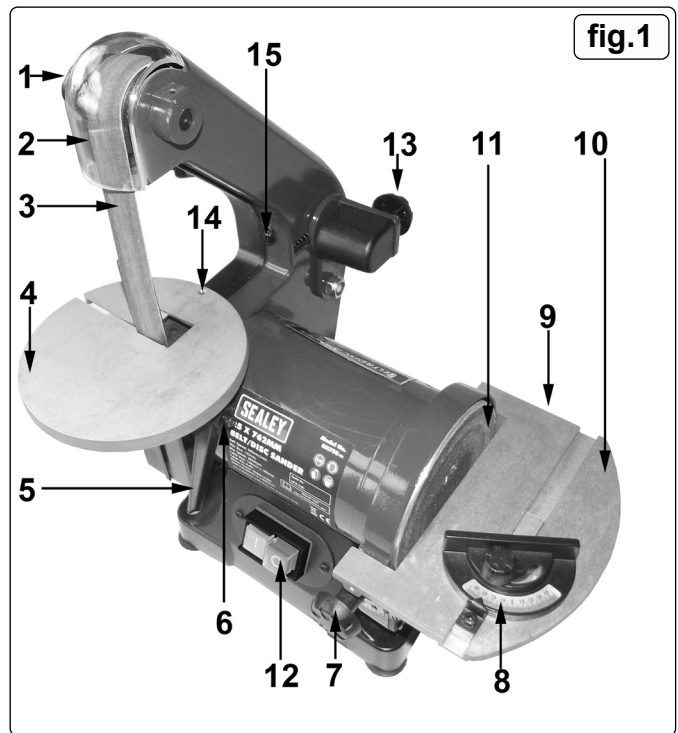

**5.3. ATTACHING THE SANDING BELT TABLE (See fig.4)**

- 5.3.1. Take the sanding belt table (a) in the orientation shown in fig.4 and allow the sanding belt to pass through the slot and into the hole in the middle of the disc. Lower the disc down until the adjusting slot (b) is adjacent to the fixing nut on the corner of the main casting.
- 5.3.2. Fix the table in position by passing the threaded portion of the inner fixing (c) through the adjusting slot (b) and into the fixing nut. Hand tighten at this stage.
- 5.3.3. Push the locking lever (d) onto the inner fixing (c) so that it engages with the splines on the end of the fixing.
- 5.3.4. Slide the spring (e) onto the plain portion of the socket head cap screw (f) and insert the bolt into the hole in the locking lever (d). Using a 3mm hex key, carefully screw the bolt into the end of the inner fixing (c). **DO NOT** overtighten.
- 5.3.5. To overcome the limited arc of movement of the locking lever, disengage it from the inner fixing by pulling it away from the table and rotate it in the direction required. Release the lever so that it re-engages with the inner fixing. You can now further tighten or loosen the fixing as required.

**5.4. SETTING THE TABLE HORIZONTAL (90° to the belt) (See fig.1 and fig.6)**

- 5.4.1. At the back of the belt table is a recessed, socket capped grub screw which is used as a stop to quickly allow the table to be returned to 90° having been set at another angle. See fig.1 item 14.
- 5.4.2. To set the stop, partially loosen the table and using a small set square, set the table surface at 90° to the belt.
- 5.4.3. Using a 3mm hex key, screw the grub screw downwards until it just touches the body of the unit without moving the table. There is a nut on the grub screw (fig.6) on the underside of the table. When you are satisfied that the stop is correctly positioned, lock it in place by tightening the nut up to the underside of the table.

**5.5. SETTING THE TABLE (>90°<150° to the belt) (See fig.5)**

- 5.5.1. From horizontal, adjust to required angle using the supplied protractor (or similar). Utilize the slot (b) in fig.4 to minimise the gap between belt and table.
- 5.5.2. Tighten the locking lever prior to sanding.

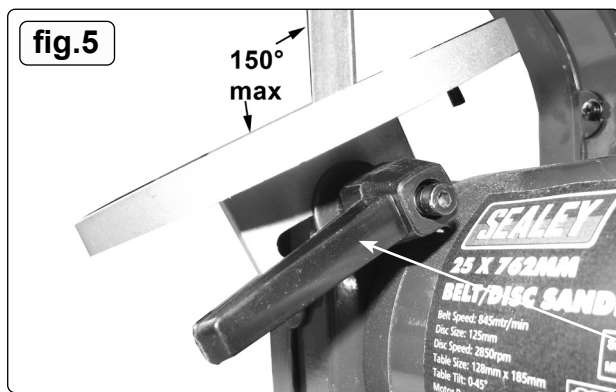

See 5.3.5. (...limited arc of locking lever...)

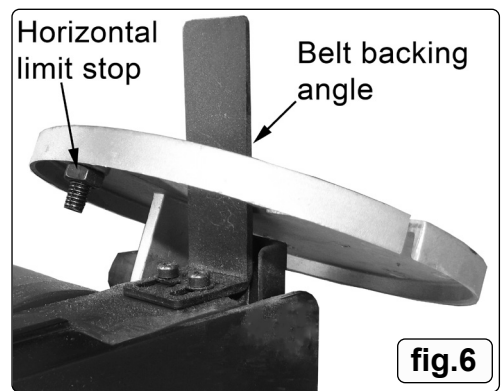

**5.6. ATTACHING THE SANDING BELT BACKING PLATE**

- 5.6.1. Referring to fig.6, position the backing angle behind the belt and insert the two socket head cap screws provided through the slots and screw them down, finger tight. See fig.7 (F), the angle face should just touch the back of the belt without applying any pressure to it.
- 5.6.2. Finally tighten the two screws with a 3mm hex key.

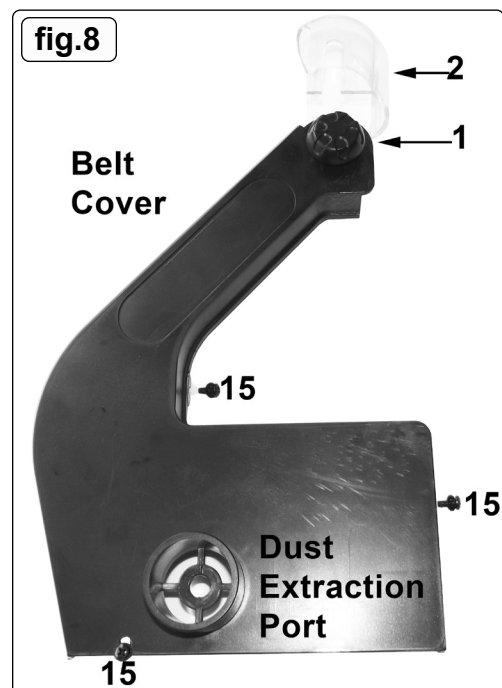
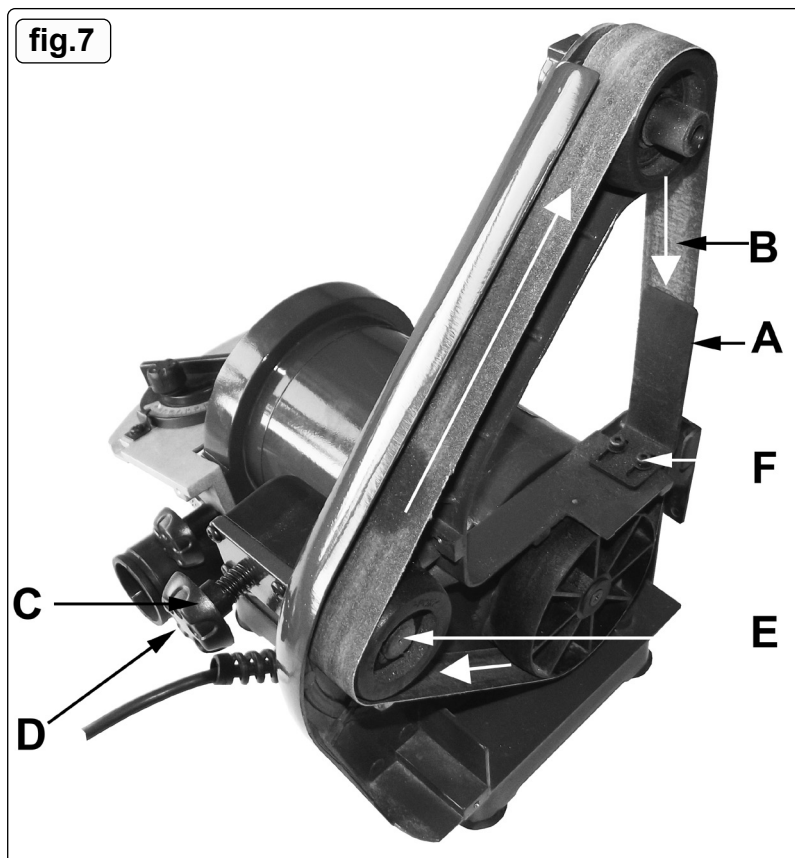

## 5.7. CHANGING THE SANDING BELT

- 5.7.1. Referring to fig.1 and fig.8, remove the cover clamp knob (1) and lift off the clear protective cover (2).
- 5.7.2. Referring again to fig.1 and fig.8, remove the two belt cover fixing screws (15) and lift off the black plastic side cover to reveal the belt and drive wheels as shown in fig.7.
- 5.7.3. Wheel (E) is spring loaded to hold the belt at the correct tension.
- 5.7.4. Push the tracking knob (D) forwards against the compression spring to relieve the tension and ease the belt off the drive wheels.
- 5.7.5. Place the new belt onto the upper and lower wheels. Push knob (D) forwards again and ease the belt back onto wheel (E).
- 5.7.6. Turn the belt by hand to see if it is running true and make any necessary adjustments using the tracking knob (C) as described in Section 6.3.1.
- 5.7.7. Re-fit the black plastic side cover over the belt and drive wheels and fix in place using the two fixing screws.
- 5.7.8. Refit the clear protective cover (2) and hold it in place with the clamp knob (1).

## 5.8. CHANGING THE SANDING DISC.

- 5.8.1. The abrasive sanding disc has an adhesive backing in order to attach it to the metal sanding disc.
- 5.8.2. If fitted, remove the adjustable angle guide from the groove in the sanding table.
- 5.8.3. Unscrew and remove the two clamp knobs from either side of the sanding disc table. Take hold of the front edge of the disc and pull it away from the disc to remove it.
- 5.8.4. Remove the four screws that hold the dust extractor cover in place and put it to one side.
- 5.8.5. Insert a blade between the back of the abrasive disc and the surface of the metal disc, taking care not to damage the metal surface. Ease the abrasive disc away from the metal surface until you can get hold of it and then peel it away from the metal disc. Remove any excess adhesive from the surface of the disc. Peel off the backing from a new abrasive disc and stick it to the metal disc ensuring it is centred.
- 5.8.6. Re-attach the exhaust cover and sanding table as described in Sections 5.1 and 5.2.

## 5.9. DUST EXTRACTION.

- 5.9.1. Both the belt and the disc are provided with dust extraction ports for connection to a workshop extractor system or a vacuum cleaner and it is recommended that these facilities be used if they are available.
- 5.9.2. If no extraction facilities are available you must wear suitable respiratory protection. Contact your local Sealey dealer for a full range of protective equipment (PPE).

# 6. OPERATION

## 6.1. PREPARATION

- 6.1.1. If the sander is to be used in a temporary work environment ensure that the rubber feet are attached in order to keep it stable in use. Wear suitable respiratory protection.
- 6.1.2. The sander can also be permanently installed in a workshop environment by removing the feet and bolting the unit to a bench using the same fixing holes as used for the feet. Ideally the sander should be connected to a dust extraction system or vacuum cleaner.
- \* **DO NOT** allow two people to use the sander at the same time.

## 6.2. DUST EXTRACTION

- 6.2.1. Both the belt and the disc are provided with dust extraction ports for connection to a workshop extractor system or a vacuum cleaner and it is recommended that these facilities be used if they are available.
- 6.2.2. If no extraction facilities are available you must wear suitable respiratory protection. Contact your local Sealey dealer for a full range of protective equipment (PPE).

## 6.3. ADJUSTING (TRACKING) THE SANDING BELT

- 6.3.1. The sanding belt supplied with the machine is factory set to run in alignment with the drive wheels. Should the belt begin to run out of true it can be re-centred using the tracking knob shown in fig.7 (C). Turn the knob clockwise to move the belt to the right, (when facing the machine). Turn the knob counter clockwise to move the belt to the left.

## 6.4. SANDING

- 6.4.1. Adjust the angle of the appropriate table and/or guide as required by the job in hand.
- 6.4.2. Plug the sander into the mains power supply.
- 6.4.3. Switch on the sander using the green ON button. See fig.1(12).
- 6.4.4. **Remember that even though you are using only one of the sanding facilities, the other is still turning and could represent a hazard to you or other people nearby.**
- 6.4.5. Allow the belt or disc to reach full speed before bringing the workpiece into contact with it. **DO NOT** use excessive force to remove material but allow the abrasive material to do its job.
- 6.4.6. Switch off the sander using the red OFF button. See fig.1(12).
- 6.4.7. Allow the disc and belt to come to a standstill before leaving the sander.
- \* **DO NOT** leave the sander running unattended.
- 6.4.8. Unplug the sander from the mains power supply when no longer required.

# 7. MAINTENANCE

- 7.1. In daily use keep the sander clean with an air line and dry cloth or brush.
- 7.2. Annually remove the side cover and remove internal accumulation of dust and ingress with an air line, vacuum cleaner or brush.
- 7.3. Visually check for belt and disc wear before each use, replacing at the first sight of damage.
- 7.4. Switch the sander off when not in use or unattended.
- 7.5. Any other maintenance outside the scope of above to be carried out by a competent technician.
- 7.6. **STORAGE**
- 7.6.1. Empty and clean the dust collection thoroughly upon completion of a sanding operation before placing the sander in storage.
- 7.6.2. Store in a child free, dry location



#### ENVIRONMENT PROTECTION

Recycle unwanted materials instead of disposing of them as waste. All tools, accessories and packaging should be sorted, taken to a recycling centre and disposed of in a manner which is compatible with the environment. When the product becomes completely unserviceable and requires disposal, drain any fluids (if applicable) into approved containers and dispose of the product and fluids according to local regulations.



REGISTER YOUR  
PURCHASE HERE



#### WEEE REGULATIONS

Dispose of this product at the end of its working life in compliance with the EU Directive on Waste Electrical and Electronic Equipment (WEEE). When the product is no longer required, it must be disposed of in an environmentally protective way. Contact your local solid waste authority for recycling information.

**Note:** It is our policy to continually improve products and as such we reserve the right to alter data, specifications and component parts without prior notice. Please note that other versions of this product are available. If you require documentation for alternative versions, please email or call our technical team on [technical@sealey.co.uk](mailto:technical@sealey.co.uk) or 01284 757505.

**Important:** No Liability is accepted for incorrect use of this product.

**Warranty:** Guarantee is 12 months from purchase date, proof of which is required for any claim.

Sealey Group, Kempson Way, Suffolk Business Park, Bury St Edmunds, Suffolk. IP32 7AR



01284 757500



[sales@sealey.co.uk](mailto:sales@sealey.co.uk)



[www.sealey.co.uk](http://www.sealey.co.uk)